

CONTROL DRAWING

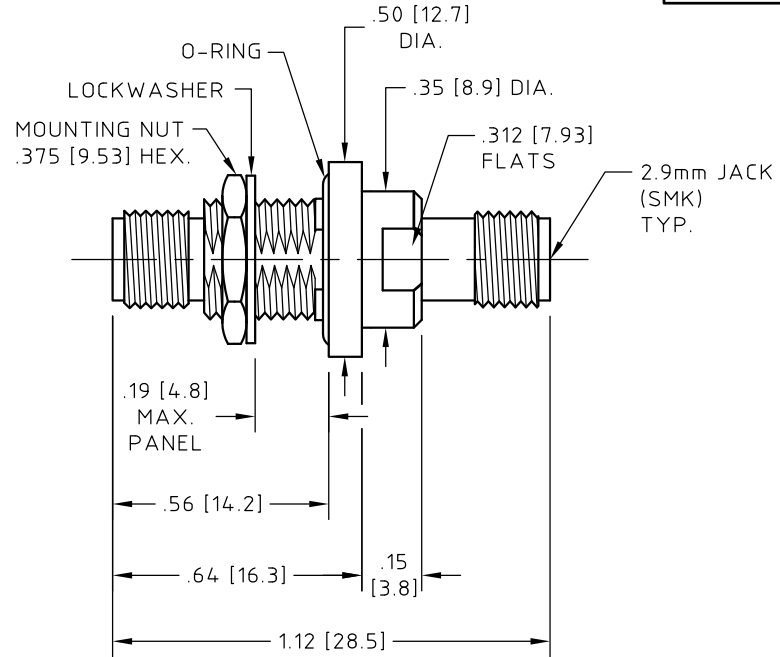

29485G-4

K

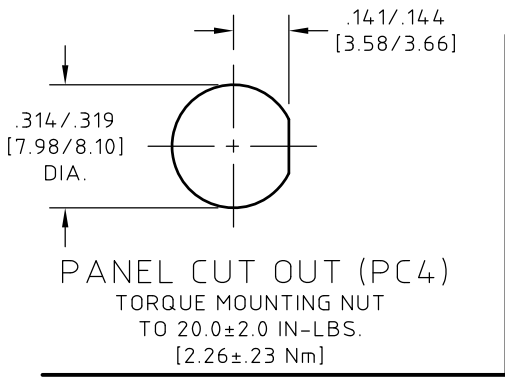

NOTES:

- DESCRIPTION,
ADAPTOR, 2.9mm JACK TO 2.9mm JACK, HERMETIC.
- MATERIALS AND FINISHES,
BODY AND MOUNTING NUT,
STEEL, CORROSION RESISTANT PER ASTM A-582,
UNS No. S30300, COND. A, NON MAGNETIC.
PASSIVATED PER SAE-AMS-2700.
NO DICHROMATE SOLUTIONS USED.
CENTER CONDUCTOR,
BERYLLIUM COPPER ALLOY PER ASTM B-196,
UNS No. C17300, TEMPER TD04(H).
GOLD PLATED 50 µIN (1.27 µM) MIN. THK.
PER ASTM B-488, CODE C, TYPE II, CLASS 1.27
OVER
NICKEL PLATE, 50 µIN (1.27 µM) MIN. THK.
PER SAE-AMS-QQ-N-290, CLASS 1.
DIELECTRIC,
POLYETHERIMIDE RESIN (PEI) (G.E. ULTEM®) PER ASTM D-5205.
AND
CORNING GLASS 7070.
FEEDTHRU BODY AND PIN,
KOVAR PER ASTM F-15 AND F-1466 (MIL-I-23011 CLASS1) UNS K94610.
GOLD PLATED 50 µIN MIN. THK. (1.27 µM)
PER ASTM B-488, CODE C, TYPE II,
OVER
NICKEL PLATE, 50 µIN MIN. THK. PER
SAE-AMS-QQ-N-290, CLASS 1.
LOCKWASHER,
COPPER ALLOY UNS No. C51000 SERIES PER ASTM B-103,
NICKEL PLATED 100 µIN MIN. THK. (2.54 µM)
PER SAE-AMS-C-26074 OR ASTM B-733.
OR
COPPER ALLOY UNS No. C42500 SERIES PER ASTM B-591 OR
NICKEL PLATED 100 µIN MIN. THK. (2.54 µM)
PER SAE-AMS-C-26074 OR ASTM B-733.
O-RING,
SILICONE RUBBER PER GSA CID A-A-59588-2B AND SAE-AMS-3304.

3. ELECTRICAL CHARACTERISTICS:

- IMPEDANCE
50.0 Ohms NOMINAL.
FREQUENCY
40.0 GHz MAX.
INSERTION LOSS
1.00 dB MAX.
VSWR
1.50 : 1 MAX.

UNLESS OTHERWISE SPECIFIED
CONCENTRICITY .004 T.I.R.
CORNERS AND FILLETS .005
MAX. RADIUS OR CHAMFER.
SURFACE FINISH 63 RMS
MICROINCHES OR BETTER.

FRACTIONS	± 1/16
X	± .030
XX	± .015
XXX	± .005
ANGLES	± 1°
DO NOT SCALE DRAWING	

NOTES CONTINUED:

- INTERFACE MEETS MIL-STD-348.
- OPERATING TEMPERATURE RANGE:
-55° C TO +125° C
- HERMETIC SEAL:
100% OF CONNECTORS ARE TESTED PER H+SAstrolab PS11606 AND
QUALIFIED FOR LEAKAGE RATES LESS THAN 1 X 10E-8 CCM/SEC
OF HELIUM UNDER PRESSURE DIFFERENTIAL OF 15.00 PSIG,
IAW ASTM E-498, AND MIL-STD-202 AND MIL-STD-883.

RoHS 5/6 COMPLIANT

NAME	DATE	<p>THIS DRAWING CONTAINS PATENTABLE AND PROPRIETARY INFORMATION. THE DESIGN CANNOT BE USED WITHOUT WRITTEN PERMISSION OF HUBER + SUHNER ASTROLAB.</p>		
PREP. E. HAGELIN	06/26/00			
ELEC.				
MECH.				
Q.C.				
TITLE		<p>ADAPTOR, 2.9mm JACK TO 2.9mm JACK HERMETIC.</p>		
THDS. TO BE IN ACCORD WITH U.S. DEPT. OF COMM. SCREW THD. STDS. FOR FEDERAL SERVICES 1950 SUPL. TO HANDBOOK H 28.	SCALE 2:1		CODE IDENT. 16301	DWG NO. 29485G-4

K	RoHS ADDED	08/26/16	LEF	
REV.	DESCRIPTION	DATE	BY	APPROVED