

MI-WAVE

Millimeter Wave Products Inc.

RF PRODUCTS AND SOLUTIONS IN 7-325 GHz
ACTIVE | PASSIVE | ANTENNAS | SUB-SYSTEMS

PRODUCT CATALOG



WWW.MI WV.COM
2007 GANDY BLVD N, SUITE 1310
ST. PETERSBURG, FL 33702

Tel: (727) 563-0034
Email: sales@miwv.com

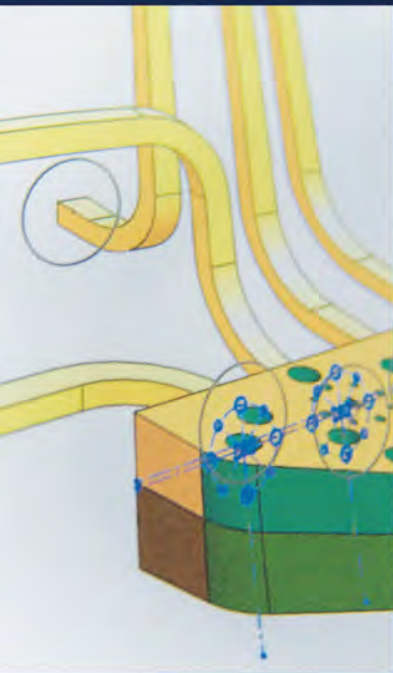
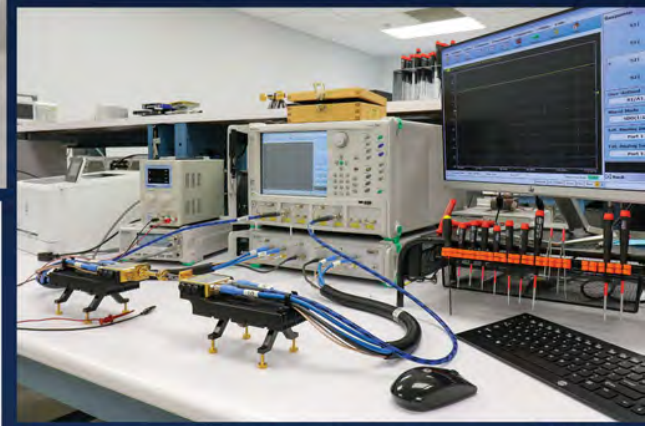
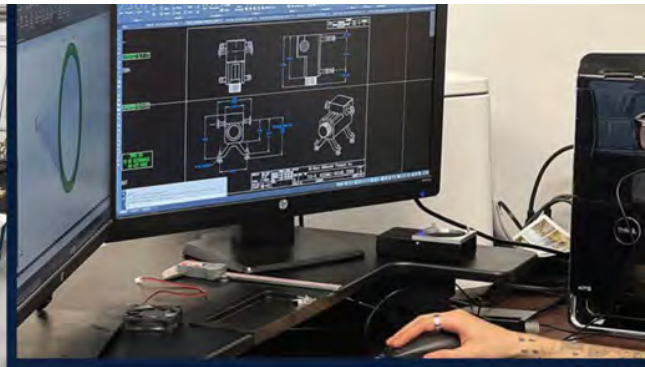

Millimeter Wave Products, Inc. is an award-winning global provider of millimeter wave products and microwave technology, components, and assemblies.

We offer volume production, individual components, systems, and MORE, in the 2GHz to 500GHz spectrum.

We manufacture all our products in our Florida, USA-based facility.

We work with a wide range of global clients, supporting research and real-world deployments across multiple industries. From standard individual components to custom-designed parts and sub assemblies, we are your best choice for Millimeter Wave and Microwave Products!

**Would you like more information about our components and capabilities?
Contact our sales and engineering team today!
Apply MiWave's experience, talent, and manufacturing resources to your project for optimized solutions!**

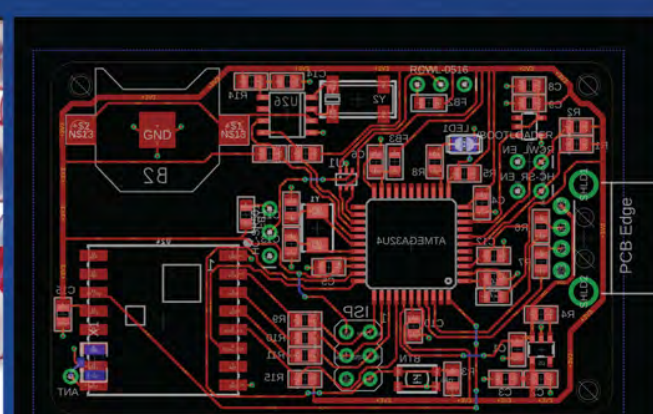

MI-WAVE

Millimeter Wave Products Inc.

Since its inception over 35 years ago, Millimeter Wave Products (Mi-Wave) has been a global leader in components and systems for both commercial and military applications ranging from 7 to 500 GHz. We are an award-winning company that has worked with more than 4000 organizations worldwide, providing full-cycle solutions across numerous industries.

Headquartered in St. Petersburg, FL, we take pride in being an American manufacturer where all of our design, development, and production is conducted here in the USA. Our 50,000 square foot facility features state-of-the-art manufacturing equipment, utilizing the latest technology in CNC machining and automation to meet critical deadlines at volume scale. With a quality-first mindset, we ensure our manufacturing processes yield high-precision components. Additionally, we have invested heavily in the latest test and measurement equipment to ensure that our products meet and exceed customer specifications with the greatest degree of accuracy.

Mi-Wave's engineering department is lead by individuals with decades of experience in designing and testing complex chip-level integrated sub-systems. Equipped with the very best in electromagnetic simulation and 3D modeling software, we excel at taking on our customers' most challenging requirements.

Our commitment to quality and customer service has attributed to tremendous growth within our industry. With our recently expanded infrastructure and ever-growing staff, we have the capacity for increasingly large-scale projects within the communication and defense sectors.

On behalf of the entire team at Mi-Wave, I'd like to thank all of our customers who continue to trust us to provide innovative, quality-driven millimeter wave products, components, and sub-assemblies. We look forward to helping you make your missions a success.



Mark Smith
President & CEO

Table of Contents

Custom Products and Projects 8-9

100 Series

115 Series: Full Band Isolators 10
 116 Series: Full Band Compact Isolators 11
 178 Series: Y-Junction Isolators. 12
 179 Series: Y-Junction Circulators 13

200 Series

202 203 Series: Prime Focus Parabolic Antenna . . . 14-16
 222/223 Series: Cassegrain Antennas 17-19
 257 Series: Spot Focus Antennas 20-21
 258 Series: Horn Lens Antennas. 22-23
 260 Series: Probe Guide Antennas 24
 261 Series: Standard Gain Horns. 25-26
 262 Series: Conical Horn Antennas 27-29
 263 Series: Wide Angle Scalar Feed Horns. 30
 264 Series: Sectorial Horn Antennas 30
 265 Series: Dual Ridge Horn Antennas 31
 267 Series: Omni-Directional Antennas 32
 268 Series: Wide Scalar Feed Horns 33
 281 Series: Orthomode Transducers. 34
 282 Series: Circular Polarizers 35
 283 Series: Linear-circular Switchable Polarizers . . . 36
 284 Series: Circular to Rectangular Waveguide Adapter 37

400 Series

410 Series: Waveguide to Coax Right Angle Transitions 38
 411 Series: Waveguide to Coax End Launch Transitions 39
 450 Series: High Pass Filters 40
 460 Series: Band Pass Filters 41
 470 Series: Low Pass Filters 42

500 Series

510 Series: Direct-reading Precision Attenuators. . . . 43
 511 Series: Programmable Rotary Vane Attenuators . . 44
 515 Series: Direct-reading Electronic Attenuators . . . 45
 520 Series: Uncalibrated Variable Attenuators. . . . 46
 522 Series: Caibrated Variable Attenuators 46
 523 Series: Micrometer Type Variable Waveguide Attenuators 47
 521 /524 Series: Fixed Attenuators 48
 525/526 Series: Uncalibrated/Calibrated Phase Shifters 49
 527 Series: Micrometer-driven Calibrated Phase Shifters 50
 528 Series: Direct-reading Phase Shifters 52
 529 Series: Motorized Rotary Vane Phase Shifters . . 51
 530 Series: Manual Waveguide Switches. 52
 535 Series: Two-position Solenoid Switches 53
 551 Series: Direct-reading Frequency Meters 54
 555 Series: Bi-directional Couplers 55
 556 Series: Blocktype Couplers 55
 559 Series: H plane Broadband Directional Couplers. 56
 560 Series: E plane Broadband Directional Couplers . 56
 561 Series: Broadband Directional Couplers 57
 564 Series: Cross Guide Directional Couplers 58
 566 Series: Cross Guide Directional Couplers 58
 567 Series: Dual-directional Couplers. 59
 580 Series: Terminations 60
 581 Series: Medium Power Load Terminations. 61
 582 Series: High Power Load Terminations. 62
 585 Series: Sliding Matched Terminations 63
 590 Series: Adjustable Waveguide Short Circuits . . . 64
 595 Series: Fixed Waveguide Short Circuits 64
 592 Series: Waveguide Shims and Spacers 65

600 Series

604 Series: Four-way Power Divider 66
 608 Series: Eight-way Power Divider 66
 620 Series: E/H Plane Tuners 67
 635 Series: Magic Tees 68
 630 Series: Block Type Tees 69
 640 Series: E-plane Tees 69
 650 Series: H-plane Tees. 69
 66X Series: E-plane Bends 70
 67X Series: H-plane Bends 70
 680 Series: 45° Twists 71
 681 Series: 90° Twists 71
 690 Series: Flanged Waveguide Sections 72
 692 Series: Tapered Transitions 73
 695 Series: Waveguide Stands. 74

Table of Contents

700 Series

705 Series: Pressurizing Units	75
707 Series: Pressure Windows	75
712 Series: Waveguide Bulkhead Adapters	76
713/714 Series: Standard Panel Mounts	76
750 Series: Blank Flanges	77
752/754/755 Series: Screws and Hardware	78
770 Series: Trihedral Reflectors	79-80
780 Series: Waveguide Calibration Kit	81

800 Series

830 Series: RF Mechanically Controlled Oscillators	82
840 Series: RF Wide Band Voltage Controlled Oscillators	82
870 Series: Noise Sources	83

900 Series

900 Series: Voltage Controlled Attenuators	84
911/912/914 Series: High-Speed Pin Diode Switches	85
920/922 Series: Harmonic Mixers	86
93(x) Series: Multipliers	87
950 Series: Finline Detectors	88
955 Series: High Power Amplifiers	89-90
955 Series: Low Noise Amplifiers	91
957 Series: Phase-locked Oscillators	92
970 Series: Wide-band Balanced Mixers	93
971 Series: I/Q Mixers	93
980 Series: Custom Frequency Converters	94
990 Series: Balanced Phase Detectors	95

Appendices

Appendix A: Rectangular Waveguides	96
Appendix B: Contact Flanges	97
Appendix C: Flange Blanks	98
Appendix D and E: Cover Flanges-Flange Blanks	99
Appendix F: Choke Flanges	99
Appendix G: Cover Flanges	100
Appendix H: Cover Flanges	101
Appendix I: Antenna TE11 Circular Waveguides	102
Appendix J: The Effect of VSWR (Typ) on Transmittal Power	103
Appendix K: Beamwidth and Gain Selection Charts	104
Terms and Conditions	105

Product Index

Amplifiers

955 Series: High Power Amplifiers	89-90
955 Series: Low Noise Amplifiers	91

Antenna Products

202 203 Series: Prime Focus Parabolic Antenna . . .	14-16
222/223 Series: Cassegrain Antennas	17-19
257 Series: Spot Focus Antennas	20-21
258 Series: Horn Lens Antennas.	22-23
260 Series: Probe Guide Antennas	24
261 Series: Standard Gain Horns.	25-26
262 Series: Conical Horn Antennas	27-29
263 Series: Wide Angle Scalar Feed Horns.	30
264 Series: Sectorial Horn Antennas	30
265 Series: Dual Ridge Horn Antennas	31
267 Series: Omni-Directional Antennas	32
268 Series: Wide Scalar Feed Horns	33
281 Series: Orthomode Transducers.	34
282 Series: Circular Polarizers	35
283 Series: Linear-circular Switchable Polarizers . . .	36
284 Series: Circular to Rectangular Waveguide Adapter	37
770 Series: Trihedral Reflectors	79-80

Attenuators

510 Series: Direct-reading Precision Attenuators. . . .	43
511 Series: Programmable Rotary Vane Attenuators . .	44
515 Series: Direct-reading Electronic Attenuators . . .	45
520 Series: Uncalibrated Variable Attenuators.	46
522 Series: Calibrated Variable Attenuators	46
523 Series: Micrometer Type Variable Waveguide Attenuators	47
521 /524 Series: Fixed Attenuators	48
900 Series: Voltage Controlled Attenuators	84

Calibration and Tuners

620 Series: E/H Plane Tuners	67
780 Series: Waveguide Calibration Kit	81

Couplers

555 Series: Bi-directional Couplers	55
556 Series: Blocktype Couplers	55
559 Series: H plane Broadband Directional Couplers.	56
560 Series: E plane Broadband Directional Couplers .	56
561 Series: Broadband Directional Couplers	57
564 Series: Cross Guide Directional Couplers	58
566 Series: Cross Guide Directional Couplers	58
567 Series: Dual-directional Couplers.	59

Detectors and Meters

551 Series: Direct-reading Frequency Meters	54
950 Series: Finline Detectors	88
990 Series: Balanced Phase Detectors	95

Dividers and Tees

604 Series: Four-way Power Divider	66
608 Series: Eight-way Power Divider	66
635 Series: Magic Tees	68
630 Series: Block Type Tees	69
640 Series: E-plane Tees	69
650 Series: H-plane Tees.	69

Filters

450 Series: High Pass Filters	40
460 Series: Band Pass Filters	41
470 Series: Low Pass Filters	42

Isolators and Circulators

115 Series: Full Band Isolators	10
116 Series: Full Band Compact Isolators.	11
178 Series: Y-Junction Isolators.	12
179 Series: Y-Junction Circulators	13

Mixers Diplexers

920/922 Series: Harmonic Mixers	86
93(x) Series: Multipliers	87
970 Series: Wide-band Balanced Mixers	93
971 Series: I/Q Mixers	93
980 Series: Custom Frequency Converters.	94

Multipliers

93(x) Series: Multipliers	87
-------------------------------------	----

Noise Sources

870 Series: Noise Sources	83
-------------------------------------	----

Oscillators

830 Series: RF Mechanically Controlled Oscillators . .	82
840 Series: RF Wide Band Voltage Controlled Oscillators	82
957 Series: Phase-locked Oscillators	92

Product Index

Phase Shifters

525/526 Series: Uncalibrated/Calibrated Phase Shifters	49
527 Series: Micrometer-driven Calibrated Phase Shifters	50
528 Series: Direct-reading Phase Shifters	52
529 Series: Motorized Rotary Vane Phase Shifters	51

Short Circuits

590 Series: Adjustable Waveguide Short Circuits	64
595 Series: Fixed Waveguide Short Circuits	64

Switches

530 Series: Manual Waveguide Switches	52
535 Series: Two-position Solenoid Switches	53
911/912/914 Series: High-Speed Pin Diode Switches	85

Terminations

580 Series: Terminations	60
581 Series: Medium Power Load Terminations	61
582 Series: High Power Load Terminations	62

Miscellaneous

592 Series: Waveguide Shims and Spacers	65
695 Series: Waveguide Stands	74
705 Series: Pressurizing Units	75
707 Series: Pressure Windows	75
713/714 Series: Standard Panel Mounts	76
750 Series: Blank Flanges	77
752/754/755 Series: Screws and Hardware	78

Transitions and Adapters

284 Series: Circular to Rectangular Waveguide Adapter	37
410 Series: Waveguide to Coax Right Angle Transitions	38
411 Series: Waveguide to Coax End Launch Transitions	39
692 Series: Tapered Transitions	73
712 Series: Waveguide Bulkhead Adapters	76

Waveguides and Bends

66X Series: E-plane Bends	70
67X Series: H-plane Bends	70
680 Series: 45° Twists	71
681 Series: 90° Twists	71
690 Series: Flanged Waveguide Sections	72

Appendices

Appendix A: Rectangular Waveguides	96
Appendix B: Contact Flanges	97
Appendix C: Flange Blanks	98
Appendix D and E: Cover Flanges-Flange Blanks	99
Appendix F: Choke Flanges	99
Appendix G: Cover Flanges	100
Appendix H: Cover Flanges	101
Appendix I: Antenna TE11 Circular Waveguides	102
Appendix J: The Effect of VSWR (Typ) on Transmittal Power	103
Appendix K: Beamwidth and Gain Selection Charts	104
Terms and Conditions	105

Custom Products and Projects

CUSTOM PROJECTS

Our RF electrical engineering capabilities allow us to work directly with customers in designing products to meet or exceed their specifications.

We build products and systems in our own manufacturing facility using state-of-the-art equipment and machinery to meet lead times. We test all components, systems, and antennas in our laboratory and anechoic chamber to ensure quality.

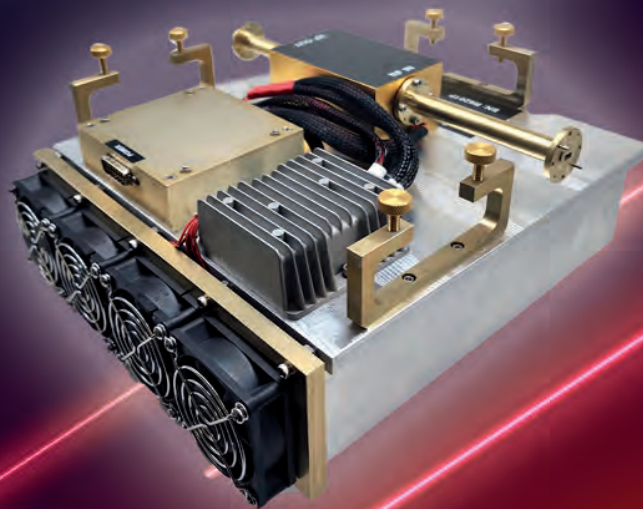

In-House Design and Manufacturing

Engage with MiWave, the industry leader in engineering and manufacturing for active and passive components. We offer unsurpassed value because we build complete solutions in our own facilities - refined over the 35 years we've served the RF Industry's Millimeter Wave Product needs.

How can we serve YOU?

**HAVE A CUSTOM NEED OR CAN'T FIND WHAT YOU'RE LOOKING FOR?
TALK TO OUR SALES ENGINEERING TEAM TODAY.
WWW.MIWW.COM**

**Tel: (727) 563-0034
Email: sales@miww.com**



Custom Built Sub-systems and Assemblies

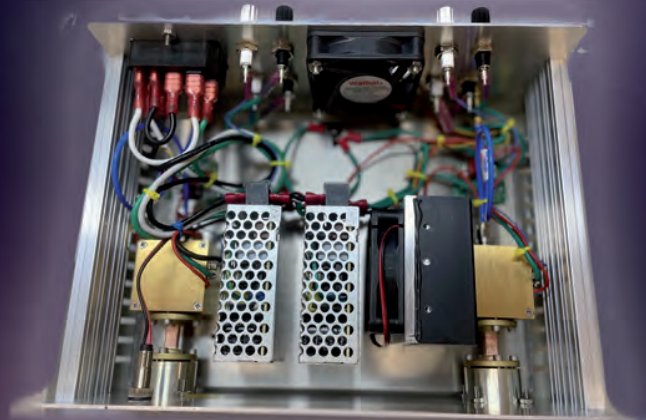
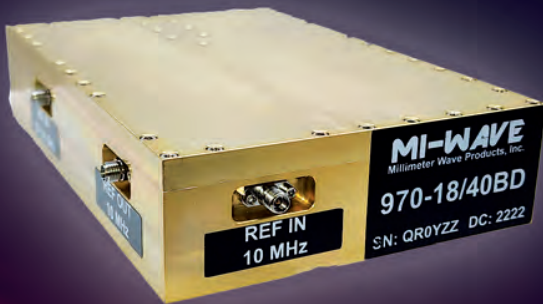
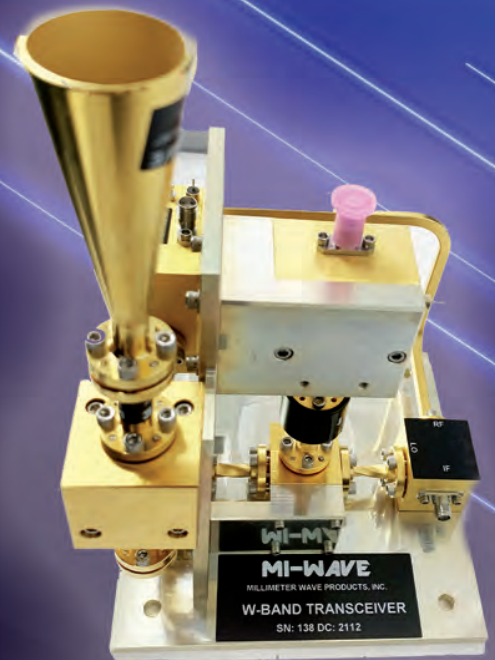
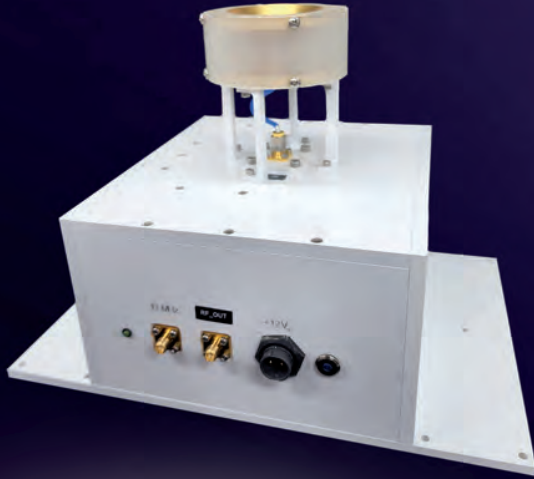

HAVE A CUSTOM NEED OR CAN'T FIND WHAT YOUR LOOKING FOR?
TALK TO OUR SALES ENGINEERING TEAM TODAY.
WWW.MI WV.COM

Tel: (727) 563-0034
Email: sales@miwv.com

115 Series

Full Band Isolators

MI-WAVE®

Millimeter Wave Products Inc.



Description

Mi-Wave's 115 series isolators use the Faraday principle of rotation in a Broadband dielectric waveguide design to achieve High Isolation across full Bands.

These faraday isolators are available in standard waveguide sizes from 18.0 to 325 GHz

- *Low Insertion Loss*
- *Full Band*
- *Excellent Isolation across the band*
- *Faraday rotation principle of operation*

Applications

- Test Labs
- Sub-Assemblies
- Automotive Industry
- MMwave Test Systems

Model Number	Band	Frequency (GHz)	Isolation (Typ)	Insertion Loss (Typ)	VSWR (Typ)	Power Handling (CW)	Input Port	Output Port
115K/595	K-Band	18-26.5	25 dB	1 dB	1.30:1	2 Watts	WR-42 Waveguide, UG-595/U Flange	WR-42 Waveguide, UG-595/U Flange
115(34)/595	WR-34	22-33	25 dB	1 dB	1.30:1	2 Watts	WR-34 Waveguide, UG-595/U Square Flange	WR-34 Waveguide, UG-595/U Square Flange
115A/599	Ka-Band	26.5-40	25 dB	1.2 dB	1.30:1	2 Watts	WR-28 Waveguide, UG-599/U Square Flange	WR-28 Waveguide, UG-599/U Square Flange
115B/383	Q-Band	33-50	25 dB	1.3 dB	1.30:1	1.5 Watts	WR-22 Waveguide, UG-383/U Round Flange	WR-22 Waveguide, UG-383/U Round Flange
115U/383	U-Band	40-60	25 dB	1.5 dB	1.30:1	1.5 Watts	WR-19 Waveguide, UG-383/U-M Round Flange	WR-19 Waveguide, UG-383/U-M Round Flange
115V/385	V-Band	50-75	25 dB	1.7 dB	1.30:1	1 Watts	WR-15 Waveguide, UG-385/U Round Flange	WR-15 Waveguide, UG-385/U Round Flange
115E/387	E-Band	60-90	25 dB	2 dB	1.35:1	1 Watts	WR-12 Waveguide, UG-387/U Round Flange	WR-12 Waveguide, UG-387/U Round Flange
115W/387	W-Band	75-110	25 dB	2.2 dB	1.40:1	1 Watts	WR-10 Waveguide, UG-387/U-M Round Flange	WR-10 Waveguide, UG-387/U-M Round Flange
115F/387	F-Band	90-140	22 dB	2.7 dB	1.50:1	0.4 Watts	WR-08 Waveguide, UG-387/U-M Round Flange	WR-08 Waveguide, UG-387/U-M Round Flange
115D/387	D-Band	110-170	20 dB	3.1 dB	1.50:1	0.2 Watts	WR-06 Waveguide, UG-387/U-M Round Flange	WR-06 Waveguide, UG-387/U-M Round Flange
115G/387	G-Band	140-220	20 dB	3.5 dB	1.50:1	0.2 Watts	WR-05 Waveguide, UG-387/U-M Round Flange	WR-05 Waveguide, UG-387/U-M Round Flange
115H/387	H-Band	170-260	20 dB	5 dB	1.50:1	0.1 Watts	WR-04 Waveguide, UG-387/U-M Round Flange	WR-04 Waveguide, UG-387/U-M Round Flange
115J/387	J-Band	220-325	20 dB	5 dB	1.50:1	0.1 Watts	WR-03 Waveguide, UG-387/U-M Round Flange	WR-03 Waveguide, UG-387/U-M Round Flange

116 Series

Full Band – Compact Isolators

MI-WAVE®
Millimeter Wave Products Inc.



Description

Mi-Wave's 116 series K-band compact isolator uses the Faraday principle of rotation in a Broadband dielectric waveguide design to achieve High Isolation across full Bands.

High-quality ferrite material is used in these isolators, and the magnetic field is produced by an integral permanent magnet.

These compact isolators are available in standard waveguide sizes from 18.0 to 325 GHz

- *Low Insertion Loss*
- *Full Band operation*
- *High Isolation*
- *Compact Size*

Applications

- Test Labs
- Sub-Assemblies
- Automotive Industry
- MMwave Test Systems

Model Number	Band	Frequency (GHz)	Isolation (Typ)	Insertion Loss (Typ)	VSWR (Typ)	Power Handling (CW)	Input Port	Output Port
116K/595	K-Band	18-26.5	25 dB	2.25 dB	1.30:1	2 Watts	WR-42 Waveguide, UG-595/U Flange	WR-42 Waveguide, UG-595/U Flange
116(34)/595	WR-34	22-33	25 dB	2.25 dB	1.30:1	2 Watts	WR-34 Waveguide, UG-595/U Square Flange	WR-34 Waveguide, UG-595/U Square Flange
116A/599	Ka-Band	26.5-40	25 dB	2.25 dB	1.30:1	1.5 Watts	WR-28 Waveguide, UG-599/U Square Flange	WR-28 Waveguide, UG-599/U Square Flange
116B/383	Q-Band	33-50	25 dB	2.55 dB	1.30:1	1.5 Watts	WR-22 Waveguide, UG-383/U Round Flange	WR-22 Waveguide, UG-383/U Round Flange
116U/383	U-Band	40-60	25 dB	2.75 dB	1.30:1	1.5 Watts	WR-19 Waveguide, UG-383/U-M Round Flange	WR-19 Waveguide, UG-383/U-M Round Flange
116V/385	V-Band	50-75	25 dB	2.95 dB	1.30:1	1 Watts	WR-15 Waveguide, UG-385/U Round Flange	WR-15 Waveguide, UG-385/U Round Flange
116E/387	E-Band	60-90	25 dB	3.25 dB	1.30:1	1 Watts	WR-12 Waveguide, UG-387/U Round Flange	WR-12 Waveguide, UG-387/U Round Flange
116W/387	W-Band	75-110	25 dB	3.45 dB	1.30:1	1 Watts	WR-10 Waveguide, UG-387/U-M Round Flange	WR-10 Waveguide, UG-387/U-M Round Flange
116F/387	F-Band	90-140	22 dB	3.95 dB	1.35:1	0.4 Watts	WR-08 Waveguide, UG-387/U-M Round Flange	WR-08 Waveguide, UG-387/U-M Round Flange
116D/387	D-Band	110-170	20 dB	4.35 dB	1.40:1	0.2 Watts	WR-06 Waveguide, UG-387/U-M Round Flange	WR-06 Waveguide, UG-387/U-M Round Flange
116G/387	G-Band	140-220	20 dB	4.75 dB	1.50:1	0.2 Watts	WR-05 Waveguide, UG-387/U-M Round Flange	WR-05 Waveguide, UG-387/U-M Round Flange
116H/387	H-Band	170-260	20 dB	6.25 dB	1.50:1	0.1 Watts	WR-04 Waveguide, UG-387/U-M Round Flange	WR-04 Waveguide, UG-387/U-M Round Flange
116J/387	J-Band	220-325	20 dB	6.25 dB	1.50:1	0.1 Watts	WR-03 Waveguide, UG-387/U-M Round Flange	WR-03 Waveguide, UG-387/U-M Round Flange

178 Series

Y-Junction Isolators

MI-WAVE®

Millimeter Wave Products Inc.



Description

Mi-Wave's 178 series is an H-plane, three-port Y-junction ferrite device with one arm internally terminated in a matched load.

Reflected energy is circulated into this load to isolate the input.

All external mating surfaces are machined to extreme flatness to provide connection to standard waveguide flanges for minimum discontinuity.

The 178 Series isolators are available in standard waveguide sizes from 18.0 to 110 GHz.

Applications

The 178 Series Y-junction isolators are useful in test setup and operational systems. These devices provide a high degree of Isolation between signal sources and system loads by sharply attenuating reflected signals with very low loss in the forward direction.

- *Optimal Temperature Response*
- *Compact Rugged*
- *Broad Bandwidth*
- *Low Loss*
- *Low VSWR*
- *High Isolation*

Model Number	Band	Frequency (GHz)	Bandwidth (Typ)	Isolation (Typ)	Insertion Loss (Typ)	VSWR (Max)	Average Power (Typ)	Peak Power	Input/Output Ports
178K-XX/595	K-Band	18-26.5	Full Band	20 dB	0.4 dB	1.3:1	30 Watts	1 kW	WR-42 Waveguide, UG-595/U Flange
178A-XX/599	Ka-Band	26.5-40	Full Band	20 dB	0.4 dB	1.3:1	30 Watts	1 kW	WR-28 Waveguide, UG-599/U Flange
178B-XX/383	Q-Band	33-50	3 GHz	20 dB	0.5 dB	1.3:1	25 Watts	1 kW	WR-22 Waveguide, UG-383/U Flange
178U-XX/383	U-Band	40-60	2 GHz	18 dB	0.7 dB	1.35:1	15 Watts	1 kW	WR-19 Waveguide, UG-383/U-M Flange
178V-XX/385	V-Band	50-75	2 GHz	18 dB	0.8 dB	1.4:1	10 Watts	1 kW	WR-15 Waveguide, UG-385/U Flange
178E-XX/387	E-Band	60-90	2 GHz	15 dB	0.9 dB	1.4:1	5 Watts	1 kW	WR-12 Waveguide, UG-387/U Flange
178W-XX/387	W-Band	75-110	2 GHz	15 dB	1 dB	1.4:1	5 Watts	1 kW	WR-10 Waveguide, UG-387/U-M Flange
178F-XX/387	F-Band	90-140	2 GHz	15 dB	1.3 dB	1.4:1	5 Watts	1 kW	WR-8 Waveguide, UG-387/U-M Flange

*XX is center frequency

179 Series

Y-Junction Circulators

MI-WAVE®

Millimeter Wave Products Inc.



Description

Mi-Wave's 179 is an H-plane, three-port Y-junction ferrite device.

All external mating surfaces are machined to extreme flatness to provide connection to standard waveguide flanges for minimum discontinuity.

The 179 Series circulators are available in standard waveguide sizes from 18.0 to 110 GHz.

Applications

179 Series Y-junction circulators are useful in test setup and operational systems.

- *Low Loss*
- *Low VSWR*
- *High Isolation*
- *Broad Bandwidth*
- *Compact Rugged*
- *Optimal Temperature Response*

Model Number	Band	Frequency (GHz)	Bandwidth (Typ)	Isolation (Typ)	Insertion Loss (Typ)	VSWR (Typ)	Average Power (Typ)	Peak Power	Input and Output Ports
179K-XX/595	K-Band	18-26.5	1.8 GHz	18 dB	0.4 dB	1.3:1	30 Watts	1 kW	WR-42 Waveguide, UG-595/U Flange
179A-XX/599	Ka-Band	26.5-40	1.5 GHz	18 dB	0.4 dB	1.3:1	30 Watts	1 kW	WR-28 Waveguide, UG-599/U Flange
179B-XX/383	Q-Band	33-50	1.5 GHz	18 dB	0.5 dB	1.3:1	25 Watts	1 kW	WR-22 Waveguide, UG-383/U Flange
179U-XX/383	U-Band	40-60	1.3 GHz	18 dB	0.7 dB	1.35:1	15 Watts	1 kW	WR-19 Waveguide, UG-383/U-M Flange
179V-XX/385	V-Band	50-75	1.3 GHz	15 dB	1 dB	1.4:1	10 Watts	1 kW	WR-15 Waveguide, UG-385/U Flange
179E-XX/387	E-Band	60-90	1.2 GHz	15 dB	1 dB	1.4:1	5 Watts	1 kW	WR-12 Waveguide, UG-387/U Flange
179W-XX/387	W-Band	75-110	1.2 GHz	15 dB	1 dB	1.4:1	5 Watts	1 kW	WR-10 Waveguide, UG-387/U-M Flange

*XX is center frequency

202/203 Series

Prime Focus Parabolic Antenna

MI-WAVE®

Millimeter Wave Products Inc.

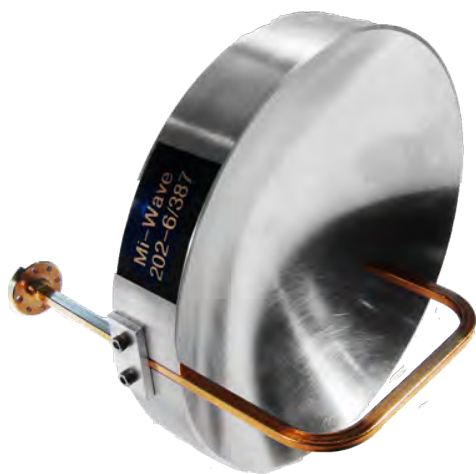

Description

Mi-Wave's 202 Series antenna consists of a parabolic reflector, a linearly-polarized primary feed, and a feed support assembly attached to the reflector's rim to position the feed accurately. Tapped holes are provided on each antenna for mounting.

- *Low Cost*
- *High Directivity and Gain (Typ)*
- *Simple Mechanical Performance*
- *Wide Range of Available Beamwidths and Reflector Sizes*

The 202 Series antennas feature a precision aluminum reflector which provides excellent performance at millimeter wave frequencies between 8.2 to 110 GHz and diameters from 3 to 24 inches are available. This design is recommended for frequencies where low surface tolerances (typically 0.001 inch RMS) are critical for electrical performance. The characteristics of the 202 Series make them well-suited for applications where high performance is necessary.

For applications that require larger diameters, the 203 Series antennas feature metalized fiberglass reflectors and cover a frequency range from 8.2 to 110 GHz. They are available in diameters from 3 to 48 inches with low surface tolerances (typically 0.0023 inch RMS).

Applications

Radar and Telemetry Systems
Point to Point Communication Links

PLEASE NOTE:

- Antenna feeds may vary due to reflector diameter performance requirements.
- Please consult Mi-Wave for further information and current dimensions.

Model Number	Band	Reflector Diameter	Frequency (GHz)	Gain (Typ)	3 dB Beamwidth	Polarization	VSWR (Typ)	Antenna Port	Reflector Material
202X-18/39 203X-18/39	X-Band	18"	8.2-12.4	29 dB	4.5°	Linear	1.3:1	WR-90 Waveguide, UG-39/U Flange	Aluminum/ Fiberglass
202X-24/39 203X-24/39	X-Band	24"	8.2-12.4	32 dB	3.5°	Linear	1.3:1	WR-90 Waveguide, UG-39/U Flange	Aluminum/ Fiberglass
202Ku-9/419	Ku-Band	9"	12.4-18	27 dB	5.8°	Linear	1.3:1	WR-62 Waveguide, UG-419/U Flange	Aluminum
202Ku-12/419 203K-12/419	Ku-Band	12"	12.4-18	30 dB	4.5°	Linear	1.3:1	WR-62 Waveguide, UG-419/U Flange	Aluminum/ Fiberglass
202Ku-18/419 203K-18/419	Ku-Band	18"	12.4-18	33 dB	3°	Linear	1.3:1	WR-62 Waveguide, UG-419/U Flange	Aluminum/ Fiberglass
202Ku-24/419 203K-24/419	Ku-Band	24"	12.4-18	36.5 dB	2°	Linear	1.3:1	WR-62 Waveguide, UG-419/U Flange	Aluminum/ Fiberglass
203Ku-36/419	Ku-Band	36"	12.4-18	40.5 dB	1.5°	Linear	1.3:1	WR-62 Waveguide, UG-419/U Flange	Fiberglass
203Ku-48/419	Ku-Band	48"	12.4-18	43 dB	1°	Linear	1.3:1	WR-62 Waveguide, UG-419/U Flange	Fiberglass
202K-6/595	K-Band	6"	18-26.5	26.5 dB	6°	Linear	1.3:1	WR-42 Waveguide, UG-595/U Flange	Aluminum
202K-9/595	K-Band	9"	18-26.5	30 dB	4°	Linear	1.3:1	WR-42 Waveguide, UG-595/U Flange	Aluminum
202K-12/595 203K-12/595	K-Band	12"	18-26.5	33 dB	3°	Linear	1.3:1	WR-42 Waveguide, UG-595/U Flange	Aluminum/ Fiberglass
202K-18/595 203K-18/595	K-Band	18"	18-26.5	36 dB	2°	Linear	1.3:1	WR-42 Waveguide, UG-595/U Flange	Aluminum/ Fiberglass
202K-24/595 203K-24/595	K-Band	24"	18-26.5	39 dB	1.5°	Linear	1.3:1	WR-42 Waveguide, UG-595/U Flange	Aluminum/ Fiberglass
203K-36/595	K-Band	36"	18-26.5	43 dB	1°	Linear	1.3:1	WR-42 Waveguide, UG-595/U Flange	Fiberglass
203K-48/595	K-Band	48"	18-26.5	45.5 dB	1°	Linear	1.3:1	WR-42 Waveguide, UG-595/U Flange	Fiberglass

202/203 Series

Prime Focus Parabolic Antenna

MI-WAVE®

Millimeter Wave Products Inc.

Model Number	Band	Reflector Diameter	Frequency (GHz)	Gain (Typ)	3 dB Beamwidth	Polarization	VSWR (Typ)	Antenna Port	Reflector Material
202A-6/599	Ka-Band	6"	26.5-40	30 dB	4.2°	Linear	1.3:1	WR-28 Waveguide, UG-599/U Flange	Aluminum
202A-9/599	Ka-Band	9"	26.5-40	33 dB	3°	Linear	1.3:1	WR-28 Waveguide, UG-599/U Flange	Aluminum
202A-12/599 203A-12/599	Ka-Band	12"	26.5-40	36 dB	2°	Linear	1.3:1	WR-28 Waveguide, UG-599/U Flange	Aluminum/ Fiberglass
202A-18/599 203A-18/599	Ka-Band	18"	26.5-40	39 dB	1.3°	Linear	1.3:1	WR-28 Waveguide, UG-599/U Flange	Aluminum/ Fiberglass
202A-24/599 203A-24/599	Ka-Band	24"	26.5-40	42 dB	1.5°	Linear	1.3:1	WR-28 Waveguide, UG-599/U Flange	Aluminum/ Fiberglass
203A-36/599	Ka-Band	36"	26.5-40	45.5 dB	1°	Linear	1.3:1	WR-28 Waveguide, UG-599/U Flange	Fiberglass
203A-48/599	Ka-Band	48"	26.5-40	48 dB	0.8°	Linear	1.3:1	WR-28 Waveguide, UG-599/U Flange	Fiberglass
202B-3/383	Q-Band	3"	33-50	26 dB	6.5°	Linear	1.3:1	WR-22 Waveguide, UG-383/U Flange	Aluminum
202B-6/383	Q-Band	6"	33-50	32 dB	3.5°	Linear	1.3:1	WR-22 Waveguide, UG-383/U Flange	Aluminum
202B-9/383	Q-Band	9"	33-50	36 dB	2.5°	Linear	1.3:1	WR-22 Waveguide, UG-383/U Flange	Aluminum
202B-12/383 203B-12/383	Q-Band	12"	33-50	38.5 dB	1.7°	Linear	1.3:1	WR-22 Waveguide, UG-383/U Flange	Aluminum/ Fiberglass
202B-18/383 203B-18/383	Q-Band	18"	33-50	42 dB	1.5°	Linear	1.3:1	WR-22 Waveguide, UG-383/U Flange	Aluminum/ Fiberglass
202B-24/383 203B-24/383	Q-Band	24"	33-50	44 dB	1°	Linear	1.3:1	WR-22 Waveguide, UG-383/U Flange	Aluminum/ Fiberglass
203B-36/383	Q-Band	36"	33-50	48 dB	0.7°	Linear	1.3:1	WR-22 Waveguide, UG-383/U Flange	Fiberglass
203B-48/383	Q-Band	48"	33-50	50 dB	0.5°	Linear	1.3:1	WR-22 Waveguide, UG-383/U Flange	Fiberglass
202U-3/383	U-Band	3"	40-60	28 dB	5.5°	Linear	1.3:1	WR-19 Waveguide, UG-383/U-M Flange	Aluminum
202U-6/383	U-Band	6"	40-60	34 dB	2.8°	Linear	1.3:1	WR-19 Waveguide, UG-383/U-M Flange	Aluminum
202U-9/383	U-Band	9"	40-60	37.5 dB	2°	Linear	1.3:1	WR-19 Waveguide, UG-383/U-M Flange	Aluminum
202U-12/383 203U-12/383	U-Band	12"	40-60	40 dB	1.5°	Linear	1.3:1	WR-19 Waveguide, UG-383/U-M Flange	Aluminum/ Fiberglass
202U-18/383 203U-18/383	U-Band	18"	40-60	43 dB	1°	Linear	1.3:1	WR-19 Waveguide, UG-383/U-M Flange	Aluminum/ Fiberglass
202U-24/383 203U-24/383	U-Band	24"	40-60	46 dB	0.7°	Linear	1.3:1	WR-19 Waveguide, UG-383/U-M Flange	Aluminum/ Fiberglass
203U-36/383	U-Band	36"	40-60	49.5 dB	0.5°	Linear	1.3:1	WR-19 Waveguide, UG-383/U-M Flange	Fiberglass
203U-48/383	U-Band	48"	40-60	52 dB	0.5°	Linear	1.3:1	WR-19 Waveguide, UG-383/U-M Flange	Fiberglass

202/203 Series

Prime Focus Parabolic Antenna

MI-WAVE®

Millimeter Wave Products Inc.

Model Number	Band	Reflector Diameter	Frequency (GHz)	Gain (Typ)	3 dB Beamwidth	Polarization	VSWR (Typ)	Antenna Port	Reflector Material
202V-3/385	V-Band	3"	50-75	30 dB	4.5°	Linear	1.3:1	WR-15 Waveguide, UG-385/U Flange	Aluminum
202V-6/385	V-Band	6"	50-75	36 dB	2.5°	Linear	1.3:1	WR-15 Waveguide, UG-385/U Flange	Aluminum
202V-9/385	V-Band	9"	50-75	39 dB	1.5°	Linear	1.3:1	WR-15 Waveguide, UG-385/U Flange	Aluminum
202V-12/385 203V-12/385	V-Band	12"	50-75	42 dB	1.2°	Linear	1.3:1	WR-15 Waveguide, UG-385/U Flange	Aluminum/ Fiberglass
202V-18/385 203V-18/385	V-Band	18"	50-75	45 dB	0.9°	Linear	1.3:1	WR-15 Waveguide, UG-385/U Flange	Aluminum/ Fiberglass
202V-24/385 203V-24/385	V-Band	24"	50-75	48 dB	0.6°	Linear	1.3:1	WR-15 Waveguide, UG-385/U Flange	Aluminum/ Fiberglass
203V-36/385	V-Band	36"	50-75	51 dB	0.4°	Linear	1.3:1	WR-15 Waveguide, UG-385/U Flange	Fiberglass
203V-48/385	V-Band	48"	50-75	54 dB	0.3°	Linear	1.3:1	WR-15 Waveguide, UG-385/U Flange	Fiberglass
202E-3/387	E-Band	3"	60-90	31 dB	3.5°	Linear	1.3:1	WR-15 Waveguide, UG-385/U Flange	Aluminum
202E-6/387	E-Band	6"	60-90	37 dB	1.8°	Linear	1.3:1	WR-15 Waveguide, UG-385/U Flange	Aluminum
202E-9/387	E-Band	9"	60-90	41 dB	1.2°	Linear	1.3:1	WR-15 Waveguide, UG-385/U Flange	Aluminum
202E-12/387 203E-12/387	E-Band	12"	60-90	43 dB	1°	Linear	1.3:1	WR-15 Waveguide, UG-385/U Flange	Aluminum/ Fiberglass
202E-18/387 203E-18/387	E-Band	18"	60-90	47 dB	0.6°	Linear	1.3:1	WR-15 Waveguide, UG-385/U Flange	Aluminum/ Fiberglass
202E-24/387 203E-24/387	E-Band	24"	60-90	49 dB	0.5°	Linear	1.3:1	WR-15 Waveguide, UG-385/U Flange	Aluminum/ Fiberglass
203E-36/387	E-Band	36"	60-90	53 dB	0.35°	Linear	1.3:1	WR-15 Waveguide, UG-385/U Flange	Fiberglass
203E-48/387	E-Band	48"	60-90	55.5 dB	0.3°	Linear	1.3:1	WR-15 Waveguide, UG-385/U Flange	Fiberglass
202W-3/387	W-Band	3"	75-110	33 dB	2.9°	Linear	1.3:1	WR-12 Waveguide, UG-387/U Flange	Aluminum
202W-6/387	W-Band	6"	75-110	39 dB	1.5°	Linear	1.3:1	WR-12 Waveguide, UG-387/U Flange	Aluminum
202W-9/387	W-Band	9"	75-110	43 dB	1°	Linear	1.3:1	WR-12 Waveguide, UG-387/U Flange	Aluminum
202W-12/387 203W-12/387	W-Band	12"	75-110	45 dB	0.8°	Linear	1.3:1	WR-12 Waveguide, UG-387/U Flange	Aluminum/ Fiberglass
202W-18/387 203W-18/387	W-Band	18"	75-110	49 dB	0.5°	Linear	1.3:1	WR-12 Waveguide, UG-387/U Flange	Aluminum/ Fiberglass
202W-24/387 203W-24/387	W-Band	24"	75-110	51 dB	0.4°	Linear	1.3:1	WR-12 Waveguide, UG-387/U Flange	Aluminum/ Fiberglass
203W-36/387	W-Band	36"	75-110	55 dB	0.25°	Linear	1.3:1	WR-12 Waveguide, UG-387/U Flange	Fiberglass
203W-48/387	W-Band	48"	75-110	57 dB	0.18°	Linear	1.3:1	WR-10 Waveguide, UG-387/U-M Flange	Fiberglass

222/223 Series

Cassegrain Antennas

MI-WAVE®

Millimeter Wave Products Inc.

Description

Mi-Wave's 222 Series Cassegrain Antenna consists of a parabolic reflector, a primary feed, a sub-reflector, and a feed support assembly of four low-profile aluminum spars that are attached to the rim of the reflector to position the feed.

- *Low VSWR*
- *Aluminum or Fiberglass Construction*
- *High Performance at Millimeter Wave Frequencies*



The 223 Series antennas feature metalized fiberglass reflectors and are available from 5.0 to 110 GHz. They offer very high performance in a lightweight antenna structure. These antennas are available in effective diameters of 10 to 48 inches. Because of the low surface tolerance (typically 0.0025 inch RMS), they provide excellent high-frequency radiation characteristics.

Applications

- Radars
- Satellite Tracking
- Communication Systems

Model Number	Band	Reflector Diameter	Circular Waveguide Internal Diameter	Frequency (GHz)	3 dB Beamwidth	Polarization	VSWR (Typ)	Antenna Port	Reflector Material
222X-18./XXX/39 223X-18./XXX/39	X-Band	18"	XXX=1.094" XXX=.938" XXX=.797"	8.2-9.97 8.5-11.6 9.97-12.4	4.5°	Circular Polarized	1.3:1	Circular Waveguide, UG-39/U Flange	Aluminum/ Fiberglass
222X-24./XXX/39 223X-24./XXX/39	X-Band	24"	XXX=1.094" XXX=.938" XXX=.797"	8.2-9.97 8.5-11.6 9.97-12.5	3.5°	Circular Polarized	1.3:1	Circular Waveguide, UG-39/U Flange	Aluminum/ Fiberglass
222Ku-18./XXX/419 223-18./XXX/419	Ku-Band	18"	XXX=.660" XXX=.550"	12.4-14.6 14.6-18	3°	Circular Polarized	1.3:1	Circular Waveguide, UG-419/U Flange	Aluminum/ Fiberglass
222Ku-24./XXX/419 223-24./XXX/419	Ku-Band	24"	XXX=.660" XXX=.550"	12.4-14.6 14.6-18	2°	Circular Polarized	1.3:1	Circular Waveguide, UG-419/U Flange	Aluminum/ Fiberglass
223Ku-36./XXX/419	Ku-Band	36"	XXX=.660" XXX=.550"	12.4-14.6 14.6-18	1.5°	Circular Polarized	1.3:1	Circular Waveguide, UG-419/U Flange	Fiberglass
223Ku-48./XXX/419	Ku-Band	48"	XXX=.660" XXX=.550"	12.4-14.6 14.6-18	1°	Circular Polarized	1.3:1	Circular Waveguide, UG-419/U Flange	Fiberglass
222K-18./XXX/595 223K-18./XXX/595	K-Band	18"	XXX=.470" XXX=.396" XXX=.328"	18-20.5 20.4-24.5 24.5-26.5	2°	Circular Polarized	1.3:1	Circular Waveguide, UG-595/U Flange or UG-425/U Flange	Aluminum/ Fiberglass
222K-24./XXX/595 223K-24./XXX/595	K-Band	24"	XXX=.470" XXX=.396" XXX=.328"	18-20.5 20.4-24.5 24.5-26.5	1.5°	Circular Polarized	1.3:1	Circular Waveguide, UG-595/U Flange or UG-425/U Flange	Aluminum/ Fiberglass
223K-36./XXX/595	K-Band	36"	XXX=.470" XXX=.396" XXX=.328"	18-20.5 20.4-24.5 24.5-26.5	1°	Circular Polarized	1.3:1	Circular Waveguide, UG-595/U Flange or UG-425/U Flange	Fiberglass
223K-48./XXX/595	K-Band	48"	XXX=.470" XXX=.396" XXX=.328"	18-20.5 20.4-24.5 24.5-26.5	1°	Circular Polarized	1.3:1	Circular Waveguide, UG-595/U Flange or UG-425/U Flange	Fiberglass
222A-18./XXX/599 223A-18./XXX/599	Ka-Band	18"	XXX=.328" XXX=.281" XXX=.250" XXX=.219"	26.5-28.5 28.5-33.0 33.0-38.5 38.5-40.0	1.3°	Circular Polarized	1.3:1	Circular Waveguide, UG-599/U Flange or UG-381/U Flange	Aluminum/ Fiberglass
222A-24./XXX/599 223A-24./XXX/599	Ka-Band	24"	XXX=.328" XXX=.281" XXX=.250" XXX=.219"	26.5-28.5 28.5-33.0 33.0-38.5 38.5-40.0	1.5°	Circular Polarized	1.3:1	Circular Waveguide, UG-599/U Flange or UG-381/U Flange	Aluminum/ Fiberglass

222/223 Series

Cassegrain Antennas

MI-WAVE®

Millimeter Wave Products Inc.

Model Number	Band	Reflector Diameter	Circular Waveguide Internal Diameter	Frequency (GHz)	3 dB Beamwidth	Polarization	VSWR (Typ)	Antenna Port	Reflector Material
223A-36/XXX/599	Ka-Band	36"	XXX=.328" XXX=.281" XXX=.250" XXX=.219"	26.5-28.5 28.5-33.0 33.0-38.5 38.5-40.0	1°	Circular Polarized	1.3:1	Circular Waveguide, UG-599/U Flange or UG-381/U Flange	Fiberglass
223A-48/XXX/599	Ka-Band	48"	XXX=.328" XXX=.281" XXX=.250" XXX=.219"	26.5-28.5 28.5-33.0 33.0-38.5 38.5-40.0	0.8°	Circular Polarized	1.3:1	Circular Waveguide, UG-599/U Flange or UG-381/U Flange	Fiberglass
222B-18/XXX/383 223B-18/XXX/383	Q-Band	18"	XXX=.250" XXX=.219" XXX=.188"	33.0-38.5 38.5-43.0 43.0-50.0	1.5°	Circular Polarized	1.3:1	Circular Waveguide, UG-383/U Flange	Aluminum/ Fiberglass
222B-24/XXX/383 223B-24/XXX/383	Q-Band	24"	XXX=.250" XXX=.219" XXX=.188"	33.0-38.5 38.5-43.0 43.0-50.0	1°	Circular Polarized	1.3:1	Circular Waveguide, UG-383/U Flange	Aluminum/ Fiberglass
223B-36/XXX/383	Q-Band	36"	XXX=.250" XXX=.219" XXX=.188"	33.0-38.5 38.5-43.0 43.0-50.0	0.7°	Circular Polarized	1.3:1	Circular Waveguide, UG-383/U Flange	Fiberglass
223B-48/XXX/383	Q-Band	48"	XXX=.250" XXX=.219" XXX=.188"	33.0-38.5 38.5-43.0 43.0-50.0	0.5°	Circular Polarized	1.3:1	Circular Waveguide, UG-383/U Flange	Fiberglass
222U-18/XXX/383 223U-18/XXX/383	U-Band	18"	XXX=.219" XXX=.188" XXX=.165" XXX=.141"	38.5-43.0 43.0-50.0 50.0-58.0 58.0-60.0	1°	Circular Polarized	1.3:1	Circular Waveguide, UG-383/U-M Flange	Aluminum/ Fiberglass
222U-24/XXX/383 223U-24/XXX/383	U-Band	24"	XXX=.219" XXX=.188" XXX=.165" XXX=.141"	38.5-43.0 43.0-50.0 50.0-58.0 58.0-60.0	0.7°	Circular Polarized	1.3:1	Circular Waveguide, UG-383/U-M Flange	Aluminum/ Fiberglass
223U-36/XXX/383	U-Band	36"	XXX=.219" XXX=.188" XXX=.165" XXX=.141"	38.5-43.0 43.0-50.0 50.0-58.0 58.0-60.0	0.5°	Circular Polarized	1.3:1	Circular Waveguide, UG-383/U-M Flange	Fiberglass
223U-48/XXX/383	U-Band	48"	XXX=.219" XXX=.188" XXX=.165" XXX=.141"	38.5-43.0 43.0-50.0 50.0-58.0 58.0-60.0	0.5°	Circular Polarized	1.3:1	Circular Waveguide, UG-383/U-M Flange	Fiberglass
222V-12/XXX/385 223V-12/XXX/385	V-Band	12"	XXX=.165" XXX=.141" XXX=.125"	50.0-58.0 58.0-68.0 68.0-75.0	1.2°	Circular Polarized	1.3:1	Circular Waveguide, UG-385/U Flange	Aluminum/ Fiberglass
222V-18/XXX/385 223V-18/XXX/385	V-Band	18"	XXX=.165" XXX=.141" XXX=.125"	50.0-58.0 58.0-68.0 68.0-75.0	0.9°	Circular Polarized	1.3:1	Circular Waveguide, UG-385/U Flange	Aluminum/ Fiberglass
222V-24/XXX/385 223V-24/XXX/385	V-Band	24"	XXX=.165" XXX=.141" XXX=.125"	50.0-58.0 58.0-68.0 68.0-75.0	0.6°	Circular Polarized	1.3:1	Circular Waveguide, UG-385/U Flange	Aluminum/ Fiberglass
223V-36/XXX/385	V-Band	36"	XXX=.165" XXX=.141" XXX=.125"	50.0-58.0 58.0-68.0 68.0-75.0	0.4°	Circular Polarized	1.3:1	Circular Waveguide, UG-385/U Flange	Fiberglass
223V-48/385	V-Band	48"	XXX=.165" XXX=.141" XXX=.125"	50.0-58.0 58.0-68.0 68.0-75.0	0.3°	Circular Polarized	1.3:1	Circular Waveguide, UG-385/U Flange	Fiberglass

PLEASE NOTE:

- The center frequency should be specified when ordering these antennas.
- Please consult Miwave for current dimensions

222/223 Series

Cassegrain Antennas

MI-WAVE®

Millimeter Wave Products Inc.

Model Number	Band	Reflector Diameter	Circular Waveguide Internal Diameter	Frequency (GHz)	3 dB Beamwidth	Polarization	VSWR (Typ)	Antenna Port	Reflector Material
222E-12/.XXX/387 223E-12/.XXX/387	E-Band	12"	XXX=.141" XXX=.125" XXX=.110" XXX=.094"	60.0-68.0 68.0-77.0 77.0-87.0 87.0-90.0	1°	Circular Polarized	1.3:1	Circular Waveguide, UG-387/U Flange	Aluminum/ Fiberglass
222E-18/.XXX/387 223E-18/.XXX/387	E-Band	18"	XXX=.141" XXX=.125" XXX=.110" XXX=.094"	60.0-68.0 68.0-77.0 77.0-87.0 87.0-90.0	0.6°	Circular Polarized	1.3:1	Circular Waveguide, UG-387/U Flange	Aluminum/ Fiberglass
222E-24/.XXX/387 223E-24/.XXX/387	E-Band	24"	XXX=.141" XXX=.125" XXX=.110" XXX=.094"	60.0-68.0 68.0-77.0 77.0- 87.0 87.0-90.0	0.5°	Circular Polarized	1.3:1	Circular Waveguide, UG-387/U Flange	Aluminum/ Fiberglass
223E-36/.XXX/387	E-Band	36"	XXX=.141" XXX=.125" XXX=.110" XXX=.094"	60.0-68.0 68.0-77.0 77.0- 87.0 87.0-90.0	0.35°	Circular Polarized	1.3:1	Circular Waveguide, UG-387/U Flange	Fiberglass
223E-48/.XXX/387	E-Band	48"	XXX=.141" XXX=.125" XXX=.110" XXX=.094"	60.0-68.0 68.0-77.0 77.0- 87.0 87.0-90.0	0.3°	Circular Polarized	1.3:1	Circular Waveguide, UG-387/U Flange	Fiberglass
222W-12/.XXX/387 223W-12/.XXX/387	W-Band	12"	XXX=.125" XXX=.110" XXX=.094" XXX=.082	75.0-77.0 77.0- 87.0 87.0-100.0 100.0-110.0	0.8°	Circular Polarized	1.3:1	Circular Waveguide, UG-387/U-M Flange	Aluminum/ Fiberglass
222W-18/.XXX/387 223W-18/.XXX/387	W-Band	18"	XXX=.125" XXX=.110" XXX=.094" XXX=.082	75.0-77.0 77.0-87.0 87.0-100.0 100.0-110.0	0.5°	Circular Polarized	1.3:1	Circular Waveguide, UG-387/U-M Flange	Aluminum/ Fiberglass
222W-24/.XXX/387 203W-24/.XXX/387	W-Band	24"	XXX=.125" XXX=.110" XXX=.094" XXX=.082	75.0-77.0 77.0-87.0 87.0-100.0 100.0-110.0	0.4°	Circular Polarized	1.3:1	Circular Waveguide, UG-387/U-M Flange	Aluminum/ Fiberglass
223W-36/.XXX/387	W-Band	36"	XXX=.125" XXX=.110" XXX=.094" XXX=.082	75.0-77.0 77.0-87.0 87.0-100.0 100.0-110.0	0.25°	Circular Polarized	1.3:1	Circular Waveguide, UG-387/U-M Flange	Fiberglass
223W-48/.XXX/387	W-Band	48"	XXX=.125" XXX=.110" XXX=.094" XXX=.082	75.0-77.0 77.0-87.0 87.0-100.0 100.0-110.0	0.18°	Circular Polarized	1.3:1	Circular Waveguide, UG-387/U-M Flange	Fiberglass

PLEASE NOTE:

- The center frequency should be specified when ordering these antennas.
- Please consult Miwave for current dimensions
- F Band available in 12-48"
- D-Band available in 12"

257 Series

Spot Focus Antennas

MI-WAVE®

Millimeter Wave Products Inc.



Description

Mi-Wave's 257 Series spot focus antennas consist of a circular scalar feed horn illuminating a piano-convex lens. Housed in either aluminum or plastic, these spot focus antennas provide a high efficiency beam with equal E and H plane amplitude patterns.

The 257 Series antennas are available from 8.2 to 220 GHz in standard sizes of 3, 6, 9, and 12 inch lens apertures. Other custom sizes and configurations are available for our spot focus antennas, please consult Mi-Wave for further information

Applications

Material evaluation, plasma diagnostics

- 8.2 to 110 GHz Available
- Simple Mechanical Performance
- Rexolite Lens
- Wide Range of Available Beamwidths and Reflector Sizes

Model Number	Band	Reflector Diameter	Circular WG Internal Diameter	Frequency (GHz)	Spot Size	Focal Length	Polarization	VSWR (Typ)	Antenna Port	Housing Material
257X-12/.XXX/39	X-Band	12"	XXX=1.094" XXX=.938" XXX=.797"	8.2-9.97 8.5-11.6 9.97-12.4	1.0-1.5"	12-14"	Circular Polarized	1.3:1	Circular Waveguide, UG-39/U Flange	HDPE
257Ku-9/.XXX/419	Ku-Band	9"	XXX=.660" XXX=.550"	12.4-14.6 14.6-18	1.0-1.5"	9-10"	Circular Polarized	1.3:1	Circular Waveguide, UG-419/U Flange	HDPE
257Ku-12/.XXX/419	Ku-Band	12"	XXX=.660" XXX=.550"	12.4-14.6 14.6-18	1.0-1.5"	12-14"	Circular Polarized	1.3:1	Circular Waveguide, UG-419/U Flange	HDPE
257K-6/.XXX/595	K-Band	6"	XXX=.470" XXX=.396" XXX=.328"	18-20.5 20.4-24.5 24.5-26.5	1.0-1.5"	8"	Circular Polarized	1.3:1	Circular Waveguide, UG-595/U Flange or UG-425/U Flange	HDPE
257K-9/.XXX/595	K-Band	9"	XXX=.470" XXX=.396" XXX=.328"	18-20.5 20.4-24.5 24.5-26.5	1.0-1.5"	9-10"	Circular Polarized	1.3:1	Circular Waveguide, UG-595/U Flange or UG-425/U Flange	HDPE
257K-12/.XXX/595	K-Band	12"	XXX=.470" XXX=.396" XXX=.328"	18-20.5 20.4-24.5 24.5-26.5	1.0-1.5"	12-14"	Circular Polarized	1.3:1	Circular Waveguide, UG-595/U Flange or UG-425/U Flange	HDPE
257A-6/.XXX/599	Ka-Band	6"	XXX=.328" XXX=.281" XXX=.250" XXX=.219"	26.5-28.5 28.5-33.0 33.0-38.5 38.5-40.0	1.0-1.5"	8"	Circular Polarized	1.3:1	Circular Waveguide, UG-599/U Flange or UG-381/U Flange	HDPE
257A-9/.XXX/599	Ka-Band	9"	XXX=.328" XXX=.281" XXX=.250" XXX=.219"	26.5-28.5 28.5-33.0 33.0-38.5 38.5-40.0	1.0-1.5"	9-10"	Circular Polarized	1.3:1	Circular Waveguide, UG-599/U Flange or UG-381/U Flange	HDPE
257A-12/.XXX/599	Ka-Band	12"	XXX=.328" XXX=.281" XXX=.250" XXX=.219"	26.5-28.5 28.5-33.0 33.0-38.5 38.5-40.0	1.0-1.5"	12-14"	Circular Polarized	1.3:1	Circular Waveguide, UG-599/U Flange or UG-381/U Flange	HDPE
257B-3/.XXX/383	Q-Band	3"	XXX=.250" XXX=.219" XXX=.188"	33.0-38.5 38.5-43.0 43.0-50.0	1.0-1.5"	4"	Circular Polarized	1.3:1	Circular Waveguide, UG-383/U Flange	Aluminum
257B-6/.XXX/383	Q-Band	6"	XXX=.250" XXX=.219" XXX=.188"	33.0-38.5 38.5-43.0 43.0-50.0	1.0-1.5"	8"	Circular Polarized	1.3:1	Circular Waveguide, UG-383/U Flange	HDPE
257B-9/.XXX/383	Q-Band	9"	XXX=.250" XXX=.219" XXX=.188"	33.0-38.5 38.5-43.0 43.0-50.0	1.0-1.5"	9-10"	Circular Polarized	1.3:1	Circular Waveguide, UG-383/U Flange	HDPE
257B-12/.XXX/383	Q-Band	12"	XXX=.250" XXX=.219" XXX=.188"	33.0-38.5 38.5-43.0 43.0-50.0	1.0-1.5"	12-14"	Circular Polarized	1.3:1	Circular Waveguide, UG-383/U Flange	HDPE

257 Series

Spot Focus Antennas

MI-WAVE®

Millimeter Wave Products Inc.

Model Number	Band	Reflector Diameter	Circular WG Internal Diameter	Frequency (GHz)	Spot Size	Focal Length	Polarization	VSWR (Typ)	Antenna Port	Housing Material
257U-3/XXX/383	U-Band	3"	XXX=.219" XXX=.188" XXX=.165" XXX=.141"	38.5-43.0 43.0-50.0 50.0-58.0 58.0-60.0	1.0-1.5"	4"	Circular Polarized	1.3:1	Circular Waveguide, UG-383/U-M Flange	Aluminum
257U-6/XXX/383	U-Band	6"	XXX=.219" XXX=.188" XXX=.165" XXX=.141"	38.5-43.0 43.0-50.0 50.0-58.0 58.0-60.0	1.0-1.5"	8"	Circular Polarized	1.3:1	Circular Waveguide, UG-383/U-M Flange	HDPE
257U-9/XXX/383	U-Band	9"	XXX=.219" XXX=.188" XXX=.165" XXX=.141"	38.5-43.0 43.0-50.0 50.0-58.0 58.0-60.0	1.0-1.5"	9-10"	Circular Polarized	1.3:1	Circular Waveguide, UG-383/U-M Flange	HDPE
257U-12/XXX/383	U-Band	12"	XXX=.219" XXX=.188" XXX=.165" XXX=.141"	38.5-43.0 43.0-50.0 50.0-58.0 58.0-60.0	1.0-1.5"	12-14"	Circular Polarized	1.3:1	Circular Waveguide, UG-383/U-M Flange	HDPE
257V-3/XXX/385	V-Band	3"	XXX=.165" XXX=.141" XXX=.125"	50.0-58.0 58.0-68.0 68.0-75.0	1.0-1.5"	4"	Circular Polarized	1.3:1	Circular Waveguide, UG-385/U Flange	Aluminum
257V-6/XXX/385	V-Band	6"	XXX=.165" XXX=.141" XXX=.125"	50.0-58.0 58.0-68.0 68.0-75.0	1.0-1.5"	8"	Circular Polarized	1.3:1	Circular Waveguide, UG-385/U Flange	HDPE
257V-9/XXX/385	V-Band	9"	XXX=.165" XXX=.141" XXX=.125"	50.0-58.0 58.0-68.0 68.0-75.0	1.0-1.5"	9-10"	Circular Polarized	1.3:1	Circular Waveguide, UG-385/U Flange	HDPE
257V-12/XXX/385	V-Band	12"	XXX=.165" XXX=.141" XXX=.125"	50.0-58.0 58.0-68.0 68.0-75.0	1.0-1.5"	12-14"	Circular Polarized	1.3:1	Circular Waveguide, UG-385/U Flange	HDPE
257E-3/XXX/387	E-Band	3"	XXX=.141" XXX=.125" XXX=.110" XXX=.094"	60.0-68.0 68.0-77.0 77.0-87.0 87.0-90.0	1.0-1.5"	4"	Circular Polarized	1.3:1	Circular Waveguide, UG-387/U Flange	Aluminum
257E-6/XXX/387	E-Band	6"	XXX=.141" XXX=.125" XXX=.110" XXX=.094"	60.0-68.0 68.0-77.0 77.0-87.0 87.0-90.0	1.0-1.5"	8"	Circular Polarized	1.3:1	Circular Waveguide, UG-387/U Flange	HDPE
257E-9/XXX/387	E-Band	9"	XXX=.141" XXX=.125" XXX=.110" XXX=.094"	60.0-68.0 68.0-77.0 77.0-87.0 87.0-90.0	1.0-1.5"	9-10"	Circular Polarized	1.3:1	Circular Waveguide, UG-387/U Flange	HDPE
257E-12/XXX/387	E-Band	12"	XXX=.141" XXX=.125" XXX=.110" XXX=.094"	60.0-68.0 68.0-77.0 77.0-87.0 87.0-90.0	1.0-1.5"	12-14"	Circular Polarized	1.3:1	Circular Waveguide, UG-387/U Flange	HDPE
257W-3/XXX/387	W-Band	3"	XXX=.125" XXX=.110" XXX=.094" XXX=.082	75.0-77.0 77.0-87.0 87.0-100.0 100.0-110.0	1.0-1.5"	4"	Circular Polarized	1.3:1	Circular Waveguide, UG-387/U-M Flange	Aluminum
257W-6/XXX/387	W-Band	6"	XXX=.125" XXX=.110" XXX=.094" XXX=.082	75.0-77.0 77.0-87.0 87.0-100.0 100.0-110.0	1.0-1.5"	8"	Circular Polarized	1.3:1	Circular Waveguide, UG-387/U-M Flange	HDPE
257W-9/XXX/387	W-Band	9"	XXX=.125" XXX=.110" XXX=.094" XXX=.082	75.0-77.0 77.0-87.0 87.0-100.0 100.0-110.0	1.0-1.5"	9-10"	Circular Polarized	1.3:1	Circular Waveguide, UG-387/U-M Flange	HDPE
257W-12/XXX/387	W-Band	12"	XXX=.125" XXX=.110" XXX=.094" XXX=.082	75.0-77.0 77.0-87.0 87.0-100.0 100.0-110.0	1.0-1.5"	12-14"	Circular Polarized	1.3:1	Circular Waveguide, UG-387/U-M Flange	HDPE

258 Series

Horn Lens Antennas

MI-WAVE®

Millimeter Wave Products Inc.



Description

Mi-Wave's 258 Series horn lens antenna consists of a circular scalar feed horn illuminating a piano-convex lens. Housed in either aluminum or plastic, these horn lens antennas provide a high efficiency beam with equal E and H plane amplitude patterns.

- 8.2 to 110 GHz Available
- Rexolite Lens
- High Directivity and Gain (Typ)
- Simple Mechanical Performance
- Wide Range of Available Beamwidths and Reflector Sizes

The 258 Series antennas are available from 8.2 to 110 GHz in standard sizes of 3, 6, 9, and 12 inch lens apertures. Other custom sizes and configurations are available, please consult Mi-Wave for further information.

Applications

Radars, Radioastronomy, Surveillance Equipment, and Communication Systems

Model Number	Band	Reflector Diameter	Circular WG Internal Diameter	Frequency (GHz)	Gain (Typ)	3 dB Beamwidth	Polarization	VSWR (Typ)	Antenna Port	Housing Material
258X-12/XXX/39	X-Band	12"	XXX=1.094" XXX=.938" XXX=.797"	8.2-9.97 8.5-11.6 9.97-12.4	26 dB	6.5°	Circular Polarized	1.3:1	Circular Waveguide, UG-39/U Flange	Aluminum
258Ku-9/XXX/419	Ku-Band	9"	XXX=.660" XXX=.550"	12.4-14.6 14.6-18	27 dB	5.8°	Circular Polarized	1.3:1	Circular Waveguide, UG-419/U Flange	Aluminum
258Ku-12/XXX/419	Ku-Band	12"	XXX=.660" XXX=.550"	12.4-14.6 14.6-18	30 dB	4.5°	Circular Polarized	1.3:1	Circular Waveguide, UG-419/U Flange	Aluminum
258K-6/XXX/595	K-Band	6"	XXX=.470" XXX=.396" XXX=.328"	18-20.5 20.4-24.5 24.5-26.5	26.5 dB	6°	Circular Polarized	1.3:1	Circular Waveguide, UG-595/U Flange or UG-425/U Flange	Aluminum or HDPE
258K-9/XXX/595	K-Band	9"	XXX=.470" XXX=.396" XXX=.328"	18-20.5 20.4-24.5 24.5-26.5	30 dB	4°	Circular Polarized	1.3:1	Circular Waveguide, UG-595/U Flange or UG-425/U Flange	Aluminum
258K-12/XXX/595	K-Band	12"	XXX=.470" XXX=.396" XXX=.328"	18-20.5 20.4-24.5 24.5-26.5	33 dB	3°	Circular Polarized	1.3:1	Circular Waveguide, UG-595/U Flange or UG-425/U Flange	Aluminum
258A-6/XXX/599	Ka-Band	6"	XXX=.328" XXX=.281" XXX=.250" XXX=.219"	26.5-28.5 28.5-33.0 33.0-38.5 38.5-40.0	30 dB	4.2°	Circular Polarized	1.3:1	Circular Waveguide, UG-599/U Flange or UG-381/U Flange	Aluminum or HDPE
258A-9/XXX/599	Ka-Band	9"	XXX=.328" XXX=.281" XXX=.250" XXX=.219"	26.5-28.5 28.5-33.0 33.0-38.5 38.5-40.0	33 dB	3°	Circular Polarized	1.3:1	Circular Waveguide, UG-599/U Flange or UG-381/U Flange	Aluminum
258A-12/XXX/599	Ka-Band	12"	XXX=.328" XXX=.281" XXX=.250" XXX=.219"	26.5-28.5 28.5-33.0 33.0-38.5 38.5-40.0	36 dB	2°	Circular Polarized	1.3:1	Circular Waveguide, UG-599/U Flange or UG-381/U Flange	Aluminum
258B-3/XXX/383	Q-Band	3"	XXX=.250" XXX=.219" XXX=.188"	33.0-38.5 38.5-43.0 43.0-50.0	26 dB	6.5°	Circular Polarized	1.3:1	Circular Waveguide, UG-383/U Flange	Aluminum
258B-6/XXX/383	Q-Band	6"	XXX=.250" XXX=.219" XXX=.188"	33.0-38.5 38.5-43.0 43.0-50.0	32 dB	3.5°	Circular Polarized	1.3:1	Circular Waveguide, UG-383/U Flange	Aluminum or HDPE
258B-9/XXX/383	Q-Band	9"	XXX=.250" XXX=.219" XXX=.188"	33.0-38.5 38.5-43.0 43.0-50.0	36 dB	2.5°	Circular Polarized	1.3:1	Circular Waveguide, UG-383/U Flange	Aluminum
258B-12/XXX/383	Q-Band	12"	XXX=.250" XXX=.219" XXX=.188"	33.0-38.5 38.5-43.0 43.0-50.0	38.5 dB	1.7°	Circular Polarized	1.3:1	Circular Waveguide, UG-383/U Flange	Aluminum

258 Series

Horn Lens Antennas

MI-WAVE®

Millimeter Wave Products Inc.

Model Number	Band	Reflector Diameter	Circular WG Internal Diameter	Frequency (GHz)	Gain (Typ)	3 dB Beamwidth	Polarization	VSWR (Typ)	Antenna Port	Housing Material
258U-3/XXX/383	U-Band	3"	XXX=.219" XXX=.188" XXX=.165" XXX=.141"	38.5-43.0 43.0-50.0 50.0-58.0 58.0-60.0	28 dB	5.5°	Circular Polarized	1.3:1	Circular Waveguide, UG-383/U-M Flange	Aluminum
258U-6/XXX/383	U-Band	6"	XXX=.219" XXX=.188" XXX=.165" XXX=.141"	38.5-43.0 43.0-50.0 50.0-58.0 58.0-60.0	34 dB	2.8°	Circular Polarized	1.3:1	Circular Waveguide, UG-383/U-M Flange	Aluminum or HDPE
258U-9/XXX/383	U-Band	9"	XXX=.219" XXX=.188" XXX=.165" XXX=.141"	38.5-43.0 43.0-50.0 50.0-58.0 58.0-60.0	37.5 dB	2°	Circular Polarized	1.3:1	Circular Waveguide, UG-383/U-M Flange	Aluminum
258U-12/XXX/383	U-Band	12"	XXX=.219" XXX=.188" XXX=.165" XXX=.141"	38.5-43.0 43.0-50.0 50.0-58.0 58.0-60.0	39 dB	1.5°	Circular Polarized	1.3:1	Circular Waveguide, UG-383/U-M Flange	Aluminum
258V-3/XXX/385	V-Band	3"	XXX=.165" XXX=.141" XXX=.125"	50.0-58.0 58.0-68.0 68.0-75.0	30 dB	4.5°	Circular Polarized	1.3:1	Circular Waveguide, UG-385/U Flange	Aluminum
258V-6/XXX/385	V-Band	6"	XXX=.165" XXX=.141" XXX=.125"	50.0-58.0 58.0-68.0 68.0-75.0	36 dB	2.5°	Circular Polarized	1.3:1	Circular Waveguide, UG-385/U Flange	Aluminum or HDPE
258V-9/XXX/385	V-Band	9"	XXX=.165" XXX=.141" XXX=.125"	50.0-58.0 58.0-68.0 68.0-75.0	39 dB	1.5°	Circular Polarized	1.3:1	Circular Waveguide, UG-385/U Flange	Aluminum
258V-12/XXX/385	V-Band	12"	XXX=.165" XXX=.141" XXX=.125"	50.0-58.0 58.0-68.0 68.0-75.0	42 dB	1.2°	Circular Polarized	1.3:1	Circular Waveguide, UG-385/U Flange	Aluminum
258E-3/XXX/387	E-Band	3"	XXX=.141" XXX=.125" XXX=.110" XXX=.094"	60.0-68.0 68.0-77.0 77.0-87.0 87.0-90.0	31 dB	3.5°	Circular Polarized	1.3:1	Circular Waveguide, UG-387/U Flange	Aluminum
258E-6/XXX/387	E-Band	6"	XXX=.141" XXX=.125" XXX=.110" XXX=.094"	60.0-68.0 68.0-77.0 77.0-87.0 87.0-90.0	37 dB	1.8°	Circular Polarized	1.3:1	Circular Waveguide, UG-387/U Flange	Aluminum or HDPE
258E-9/XXX/387	E-Band	9"	XXX=.141" XXX=.125" XXX=.110" XXX=.094"	60.0-68.0 68.0-77.0 77.0-87.0 87.0-90.0	41 dB	1.2°	Circular Polarized	1.3:1	Circular Waveguide, UG-387/U Flange	Aluminum
258E-12/XXX/387	E-Band	12"	XXX=.141" XXX=.125" XXX=.110" XXX=.094"	60.0-68.0 68.0-77.0 77.0-87.0 87.0-90.0	43 dB	1°	Circular Polarized	1.3:1	Circular Waveguide, UG-387/U Flange	Aluminum
258W-3/XXX/387	W-Band	3"	XXX=.125" XXX=.110" XXX=.094" XXX=.082	75.0-77.0 77.0-87.0 87.0-100.0 100.0-110.0	33 dB	2.9°	Circular Polarized	1.3:1	Circular Waveguide, UG-387/U-M Flange	Aluminum
258W-6/XXX/387	W-Band	6"	XXX=.125" XXX=.110" XXX=.094" XXX=.082	75.0-77.0 77.0-87.0 87.0-100.0 100.0-110.0	39 dB	1.5°	Circular Polarized	1.3:1	Circular Waveguide, UG-387/U-M Flange	Aluminum or HDPE
258W-9/XXX/387	W-Band	9"	XXX=.125" XXX=.110" XXX=.094" XXX=.082	75.0-77.0 77.0-87.0 87.0-100.0 100.0-110.0	42 dB	1°	Circular Polarized	1.3:1	Circular Waveguide, UG-387/U-M Flange	Aluminum
258W-12/XXX/387	W-Band	12"	XXX=.125" XXX=.110" XXX=.094" XXX=.082	75.0-77.0 77.0-87.0 87.0-100.0 100.0-110.0	45 dB	0.8°	Circular Polarized	1.3:1	Circular Waveguide, UG-387/U-M Flange	Aluminum

260 Series

Probe Guide Antennas

MI-WAVE®
Millimeter Wave Products Inc.

Description

Mi-Wave's 260 Series Waveguide Probe Antennas are used in a wide variety of applications due to their high power handling capability, low loss, high directivity, and near-constant electrical performance across a broad bandwidth. Mi-wave's probe antennas offer operating frequencies from 8.2-500 GHz. These antennas offer a low gain variation across their operating frequency.

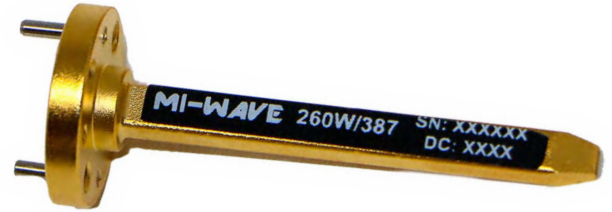

Model	Band	Low Frequency (GHz)	High Frequency (GHz)	Gain (Typ)	Length (Inches)	Port
260X/39	X-Band	8.2	12.4	5.2 dB	4.5	WR-90 Waveguide UG-39/U Flange
260K/595	K-Band	18	26.5	4.6 dB	4.72	WR-42 Waveguide UG-595/U Flange
260A/599	Ka-Band	26.5	40	4.9 dB	2	WR-28 Waveguide UG-599/U Flange
260B/383	Q-Band	33	50	4.9 dB	2	WR-22 Waveguide UG-383/U Flange
260U/383	U-Band	40	60	5 dB	2	WR-19 Waveguide UG-383/U-M Flange
260V/385	V-Band	50	75	4.9 dB	2	WR-15 Waveguide UG-385/U Flange
260E/387	E-Band	60	90	4.8 dB	2	WR-12 Waveguide UG-387/U Flange
260W/387	W-Band	75	110	4.8 dB	2	WR-10 Waveguide UG-387/U-M Flange
260F/387	F-Band	90	140	4.9 dB	2	WR-08 Waveguide UG-387/U-M Flange
260G/387	G-Band	140	220	4.9 dB	1.5	WR-05 Waveguide UG-387/U-M Flange
260H/387	H-Band	170	260	4.9 dB	1.25	WR-04 Waveguide UG-387/U-M Flange
260J/387	J-Band	220	325	4.9 dB	1.5	WR-03 Waveguide UG-387/U-M Flange
260(Q.2)/387	WR-2.2	325	500	4.9 dB	1.0	WR-2.2 Waveguide UG-387/U-M Flange

261 Series

Standard Gain Horns

MI-WAVE®

Millimeter Wave Products Inc.

Description

MiWave manufactures each 261 Series standard Gain Horn with very precise tolerances to ensure optimal performance

Standard Gain Horns can be used to experimentally determine the Gain of other antennas by using the substitution method. The standard Gain Horn and the antenna under test are alternately connected to a well-matched detector system in order to compare their relative power levels.

The power level difference is then added to the appropriate level of the calibration curve to determine the absolute Gain of the antenna under test.

Standard Gain Horns are also useful as power monitors in radar transmitter tests, known-Gain radiators in field propagation studies, and transmitting or receiving antennas in test bench applications. The completed units are gold-plated to protect from corrosion and for minimum RF losses depending on frequency band

- *Nominal Gain of 25 dB*
- *Available from 8.2 to 750 GHz*
- *Made with precise dimensional tolerance control*
- *Gain Calibration is accurate to 0.5 dB over full Bandwidth*
- *Other Gain values available upon request (ex: 10, 15, 20, etc.)*



Model Number	Frequency (GHz)	Gain (Typ)	Polarization	-3dB Beamwidth (E-Plane)	-3dB Beamwidth (H-Plane)	Side Lobes (E-Plane)	Side Lobes (H-Plane)	Port
261X-15/39	8.2-12.4	15 dB	Linear	29.3 dB	29 dB	20 dB	20 dB	WR-90 Waveguide, UG-39 Flange
261(75)-20/120	10-15	20 dB	Linear	16.22 dB	19.81 dB	18 dB	18 dB	WR-75 waveguide UBR-120/U Flange
261Ku-20/419	12-18	20 dB	Linear	16.9 dB	17.8 dB	18 dB	18 dB	WR-90 Waveguide UG-419/U Flange
261K-10/595	18-26.5	10 dB	Linear	19 dB	21 dB	20 dB	20 dB	WR-42 Waveguide UG-595/U Flange
261K-15/595	18-26.5	15 dB	Linear	19 dB	21 dB	20 dB	20 dB	WR-42 Waveguide UG-595/U Flange
261K-20/595	18-26.5	20 dB	Linear	19 dB	21 dB	20 dB	20 dB	WR-42 Waveguide UG-595/U Flange
261A-10/599	26.5-40	10 dB	Linear	56 dB	54 dB	20 dB	20 dB	WR-28 Waveguide UG-599/U Flange
261A-15/599	26.5-40	15 dB	Linear	33 dB	33 dB	20 dB	20 dB	WR-28 Waveguide UG-599/U Flange
261A-20/599	26.5-40	20 dB	Linear	16.57 dB	16.58 dB	20 dB	20 dB	WR-28 Waveguide UG-599/U Flange
261A-25/599	26.5-40	25 dB	Linear	7 dB	9 dB	20 dB	20 dB	WR-28 Waveguide UG-599/U Flange
261B-15/383	33-50	15 dB	Linear	39.81 dB	25.9 dB	20 dB	20 dB	WR-22 Waveguide UG-383/U Flange
261B-20/383	30-50	20 dB	Linear	15 dB	16 dB	20 dB	20 dB	WR-22 Waveguide UG-383/U Flange
261B-25/383	33-50	25 dB	Linear	7 dB	9 dB	20 dB	20 dB	WR-22 Waveguide UG-383/U Flange
261U-10/383	40-60	10 dB	Linear	55 dB	55 dB	20 dB	20 dB	WR-19 Waveguide UG-383/U-M Flange
261U-15/383	40-60	15 dB	Linear	32 dB	32 dB	20 dB	20 dB	WR-19 Waveguide UG-383/U-M Flange
261U-20/383	40-60	20 dB	Linear	14 dB	16 dB	20 dB	30 dB	WR-19 Waveguide UG-383/U-M Flange
261U-25/383	40-60	25 dB	Linear	9 dB	10 dB	20 dB	20 dB	WR-19 Waveguide UG-383/U-M Flange
261V-10/385	50-75	10 dB	Linear	55 dB	55 dB	20 dB	20 dB	WR-15 Waveguide UG-385/U-M Flange
261V-15/385	50-75	15 dB	Linear	29 dB	32 dB	20 dB	20 dB	WR-15 Waveguide UG-385/U-M Flange
261V-20/385	50-75	20 dB	Linear	14 dB	15 dB	20 dB	20 dB	WR-15 Waveguide UG-385/U Flange
261V-25/385-FL	50-75	25 dB	Linear	9 dB	10 dB	20 dB	20 dB	WR-15 Waveguide UG-385/U Flange

261 Series

Standard Gain Horns

MI-WAVE®

Millimeter Wave Products Inc.

Model Number	Frequency (GHz)	Gain (Typ)	Polarization	-3dB Beamwidth (E-Plane)	-3dB Beamwidth (H-Plane)	Side Lobes (E-Plane)	Side Lobes (H-Plane)	Port
261E-10/387	60-90	10 dB	Linear	55 dB	55 dB	20 dB	20 dB	WR-12 Waveguide UG-387/U Flange
261E-15/387	60-90	15 dB	Linear	30 dB	32 dB	20 dB	20 dB	WR-12 Waveguide UG-387/U Flange
261E-20/387	60-90	20 dB	Linear	14 dB	15 dB	20 dB	20 dB	WR-12 Waveguide UG-387/U Flange
261E-25/387	60-90	25 dB	Linear	9 dB	10 dB	20 dB	20 dB	WR-12 Waveguide UG-387/U Flange
261W-10/387	75-110	10 dB	Linear	51.76 dB	52 dB	20 dB	20 dB	WR-10 Waveguide UG-387/U-M Flange
261W-15/387	75-110	15 dB	Linear	32 dB	32 dB	20 dB	20 dB	WR-10 Waveguide UG-387/U-M Flange
261W-20/387	75-110	20 dB	Linear	16 dB	18 dB	20 dB	20 dB	WR-10 Waveguide UG-387/U-M Flange
261W-25/387-FL	75-110	25 dB	Linear	9 dB	10 dB	20 dB	20 dB	WR-10 Waveguide UG-387/U-M Flange
261F-10/387	90-140	10 dB	Linear	53 dB	55 dB	20 dB	20 dB	WR-08 Waveguide UG-387/U-M Flange
261F-15/387	90-140	15 dB	Linear	29.73 dB	33.67 dB	20 dB	20 dB	WR-08 Waveguide UG-387/U-M Flange
261F-20/387	90-140	20 dB	Linear	16 dB	18 dB	20 dB	20 dB	WR-08 Waveguide UG-387/U-M Flange
261F-25/387	90-140	25 dB	Linear	9 dB	10 dB	20 dB	20 dB	WR-08 Waveguide UG-387/U-M Flange
261D-15/387	110-170	15 dB	Linear	33 dB	31 dB	20 dB	20 dB	WR-06 Waveguide UG-387/U-M Flange
261D-20/387	110-170	20 dB	Linear	17 dB	18 dB	20 dB	20 dB	WR-06 Waveguide UG-387/U-M Flange
261D-25/387	110-170	25 dB	Linear	25 dB	25.5 dB	20 dB	20 dB	WR-06 Waveguide UG-387/U-M Flange
261G-10/387	140-220	10 dB	Linear	56 dB	54 dB	20 dB	20 dB	WR-05 Waveguide UG-387/U-M Flange
261G-15/387	140-220	15 dB	Linear	33.41 dB	31.9 dB	20 dB	20 dB	WR-05 Waveguide UG-387/U-M Flange
261G-20/387	140-220	20 dB	Linear	13 dB	13 dB	20 dB	20 dB	WR-05 Waveguide UG-387/U-M Flange
261G-25/387	140-220	25 dB	Linear	8.9 dB	10.28 dB	20 dB	20 dB	WR-05 Waveguide UG-387/U-M Flange
261H-25/387	170-260	25 dB	Linear	10 dB	10 dB	20 dB	20 dB	WR-04 Waveguide UG-387/U Flange
261J-15/387	220-325	15 dB	Linear	35 dB	38 dB	20 dB	20 dB	WR-3 Waveguide UG-387/U-M Flange
261J-25/387	220-325	25 dB	Linear	9 dB	10 dB	20 dB	20 dB	WR-3 Waveguide UG-387/U-M Flange
261(2.8)-25/387	260-400	25 dB	Linear	26.18 dB	25.8 dB	20 dB	20 dB	WR-2.8 Waveguide UG-387/U-M Flange
261(2.2)/387	325-500	25 dB	Linear	13 dB	15 dB	20 dB	20 dB	WR-2.2 Waveguide UG-387/U-M Flange
261(1.5)-25/387	500-750	25 dB	Linear	dB	dB	20 dB	20 dB	WR-1.5 Waveguide UG-387/U-M Flange

262 Series

Conical Horn Antennas

MI-WAVE®

Millimeter Wave Products Inc.



Description

Mi-Wave's 262 Series Conical horns are fabricated with very close tolerances to ensure the precision of every horn manufactured by Mi-Wave.

Conical horns can be used to experimentally determine the Gain of other antennas by using the substitution method. The conical horn and the antenna under test are alternately connected to a well-matched detector system in order to compare their relative power levels.

Conical horns are also useful as power monitors in radars transmitter test, known-Gain radiators in field propagation studies, and transmitting or receiving antennas in test bench applications.

- Available from 8.2 to 325 GHz
- Nominal Gain of 10, 15, 20, and 25 dBi
- Made with Precise Dimensional Tolerance Control
- Gain Calibration is accurate to 0.5 dB over operating bandwidth.

Model Number	Band	Frequency (GHz)	Circular WG Internal Diameter	Gain (Typ)	3dB Beamwidth (E-Plane)	3dB Beamwidth (H-Plane)	Port
262X-10/.XXX/39	X-Band	8.2-9.97 8.5-11.6 9.97-12.4	XXX=1.094" XXX=.938" XXX=.797"	10 dBi	59.42°	57.7°	Circular Waveguide, UG-39/U Flange
262X-15/.XXX/39	X-Band	8.2-9.97 8.5-11.6 9.97-12.4	XXX=1.094" XXX=.938" XXX=.797"	15 dBi	15.28°	18.54°	Circular Waveguide, UG-39/U Flange
262KU-10/.XXX/419	Ku-Band	12.4-14.6 14.6-18.0	XXX=.660" XXX=.550"	10 dBi	47.67°	50.04°	Circular Waveguide, UG-419/U Flange
262Ku-15/.XXX/419	Ku-Band	12.4-14.6 14.6-18.0	XXX=.660" XXX=.550"	15 dBi	28.25°	32.96°	Circular Waveguide, UG-419/U Flange
262K-10/.XXX/595	K-Band	18.0-20.5 20.4-24.5 24.5-26.5	XXX=.470" XXX=.396" XXX=.328"	10 dBi	45.72°	48.54°	Circular Waveguide, UG-595/U Flange or UG-425/U Flange
262K-15/.XXX/595	K-Band	18.0-20.5 20.4-24.5 24.5-26.5	XXX=.470" XXX=.396" XXX=.328"	15 dBi	26.5°	31.13°	Circular Waveguide, UG-595/U Flange or UG-425/U Flange
262K-20/.XXX/595	K-Band	18.0-20.5 20.4-24.5 24.5-26.5	XXX=.470" XXX=.396" XXX=.328"	20 dBi	14.48°	17.61°	Circular Waveguide, UG-595/U Flange or UG-425/U Flange
262A-10/.XXX/599	Ka-Band	26.5-28.5 28.5-33.0 33.0-38.5 38.5-40.0	XXX=.328" XXX=.281" XXX=.250" XXX=.219"	10 dBi	47.64°	49.03°	Circular Waveguide, UG-599/U Flange or UG-381/U Flange
262A-15/.XXX/599	Ka-Band	26.5-28.5 28.5-33.0 33.0-38.5 38.5-40.0	XXX=.328" XXX=.281" XXX=.250" XXX=.219"	15 dBi	23.44°	27.94°	Circular Waveguide, UG-599/U Flange or UG-381/U Flange
262A-20/.XXX/599	Ka-Band	26.5-28.5 28.5-33.0 33.0-38.5 38.5-40.0	XXX=.328" XXX=.281" XXX=.250" XXX=.219"	20 dBi	15.9°	19.39°	Circular Waveguide, UG-599/U Flange or UG-381/U Flange
262A-25/.XXX/599	Ka-Band	26.5-28.5 28.5-33.0 33.0-38.5 38.5-40.0	XXX=.328" XXX=.281" XXX=.250" XXX=.219"	25 dBi	8.62°	10.55°	Circular Waveguide, UG-599/U Flange or UG-381/U Flange
262B-10/.XXX/383	Q-Band	33.0-38.5 38.5-43.0 43.0-50.0	XXX=.250" XXX=.219" XXX=.188"	10 dBi	49.92°	51.66°	Circular Waveguide, UG-383/U Flange
262B-15/.XXX/383	Q-Band	33.0-38.5 38.5-43.0 43.0-50.0	XXX=.250" XXX=.219" XXX=.188"	15 dBi	25.27°	29.88°	Circular Waveguide, UG-383/U Flange

262 Series

Conical Horn Antennas

MI-WAVE®

Millimeter Wave Products Inc.

Model Number	Band	Frequency (GHz)	Circular WG Internal Diameter	Gain (Typ)	3dB Beamwidth (E-Plane)	3dB Beamwidth (H-Plane)	Port
263B-20/XXX/383	Q-Band	33.0-38.5 38.5-43.0 43.0-50.0	XXX=.250" XXX=.219" XXX=.188"	20 dBi	14.36°	17.56°	Circular Waveguide, UG-383/U Flange
262B-25/XXX/383	Q-Band	33.0-38.5 38.5-43.0 43.0-50.0	XXX=.250" XXX=.219" XXX=.188"	25 dBi	8.23°	9.96°	Circular Waveguide, UG-383/U Flange
262U-10/XXX/383	U-Band	38.5-43.0 43.0-50.0 50.0-58.0 58.0-60.0	XXX=.219" XXX=.188" XXX=.165" XXX=.141"	10 dBi	54.64°	54.84°	Circular Waveguide, UG-383/U-M Flange
262U-15/XXX/383	U-Band	38.5-43.0 43.0-50.0 50.0-58.0 58.0-60.0	XXX=.219" XXX=.188" XXX=.165" XXX=.141"	15 dBi	29.53°	34.39°	Circular Waveguide, UG-383/U-M Flange
262U-20/XXX/383	U-Band	38.5-43.0 43.0-50.0 50.0-58.0 58.0-60.0	XXX=.219" XXX=.188" XXX=.165" XXX=.141"	20 dBi	12.34°	15.17°	Circular Waveguide, UG-383/U-M Flange
262U-25/XXX/383	U-Band	38.5-43.0 43.0-50.0 50.0-58.0 58.0-60.0	XXX=.219" XXX=.188" XXX=.165" XXX=.141"	25 dBi	8.78°	10.76°	Circular Waveguide, UG-383/U-M Flange
262V-10/XXX/385	V-Band	50.0-58.0 58.0-68.0 68.0-75.0	XXX=.165" XXX=.141" XXX=.125"	10 dBi	55.99°	55.68°	Circular Waveguide, UG-385/U Flange
262V-15/XXX/385	V-Band	50.0-58.0 58.0-68.0 68.0-75.0	XXX=.165" XXX=.141" XXX=.125"	15 dBi	29.69°	34.56°	Circular Waveguide, UG-385/U Flange
262V-20/XXX/385	V-Band	50.0-58.0 58.0-68.0 68.0-75.0	XXX=.165" XXX=.141" XXX=.125"	20 dBi	15.22°	18.64°	Circular Waveguide, UG-385/U Flange
262V-25/XXX/385	V-Band	50.0-58.0 58.0-68.0 68.0-75.0	XXX=.165" XXX=.141" XXX=.125"	25 dBi	7.68°	9.32°	Circular Waveguide, UG-385/U Flange
262E-10/XXX/387	E-Band	60.0-68.0 68.0-77.0 77.0-87.0 87.0-90.0	XXX=.141" XXX=.125" XXX=.110" XXX=.094"	10 dBi	51.39°	52.7°	Circular Waveguide, UG-387/U Flange
262E-15/XXX/387	E-Band	60.0-68.0 68.0-77.0 77.0-87.0 87.0-90.0	XXX=.141" XXX=.125" XXX=.110" XXX=.094"	15 dBi	28.39°	33.22°	Circular Waveguide, UG-387/U Flange
262E-20/XXX/387	E-Band	60.0-68.0 68.0-77.0 77.0-87.0 87.0-90.0	XXX=.141" XXX=.125" XXX=.110" XXX=.094"	20 dBi	15.59°	18.97°	Circular Waveguide, UG-387/U Flange
262E-25/XXX/387	E-Band	60.0-68.0 68.0-77.0 77.0-87.0 87.0-90.0	XXX=.141" XXX=.125" XXX=.110" XXX=.094"	25 dBi	8°	9.74°	Circular Waveguide, UG-387/U Flange
262W-10/XXX/387	W-Band	75.0-77.0 77.0-87.0 87.0-100.0 100.0-110.0	XXX=.125" XXX=.110" XXX=.094" XXX=.082"	10 dBi	60.48°	58.32°	Circular Waveguide, UG-387/U-M Flange
262W-15/XXX/387	W-Band	75.0-77.0 77.0-87.0 87.0-100.0 100.0-110.0	XXX=.125" XXX=.110" XXX=.094" XXX=.082"	15 dBi	29.86°	34.73°	Circular Waveguide, UG-387/U-M Flange
262W-20/XXX/387	W-Band	75.0-77.0 77.0-87.0 87.0-100.0 100.0-110.0	XXX=.125" XXX=.110" XXX=.094" XXX=.082"	20 dBi	16.33°	19.96°	Circular Waveguide, UG-387/U-M Flange

262 Series

Conical Horn Antennas

MI-WAVE®

Millimeter Wave Products Inc.

Model Number	Band	Frequency (GHz)	Circular WG Internal Diameter	Gain (Typ)	3dB Beamwidth (E-plane)	3dB Beamwidth (H-plane)	Port
262W-25/XXX/387	W-Band	75.0-77.0 77.0-87.0 87.0-100.0 100.0-110.0	XXX=.125" XXX=.110" XXX=.094" XXX=.082	25 dBi	9.32°	11.37°	Circular Waveguide, UG-387/U-M Flange
262F-10/XXX/387	F-Band	87.0-100.0 100.0-112.0 112.0-125.0 125.0-140.0	XXX=.094" XXX=.082" XXX=.075" XXX=.067"	10 dBi	55.75°	55.54°	Circular Waveguide, UG-387/U-M Flange
262F-15/XXX/387	F-Band	87.0-100.0 100.0-112.0 112.0-125.0 125.0-140.0	XXX=.094" XXX=.082" XXX=.075" XXX=.067"	15 dBi	30.81°	35.41°	Circular Waveguide, UG-387/U-M Flange
262F-20/XXX/387	F-Band	87.0-100.0 100.0-112.0 112.0-125.0 125.0-140.0	XXX=.094" XXX=.082" XXX=.075" XXX=.067"	20 dBi	14.54°	17.87°	Circular Waveguide, UG-387/U-M Flange
262F-25/XXX/387	F-Band	87.0-100.0 100.0-112.0 112.0-125.0 125.0-140.0	XXX=.094" XXX=.082" XXX=.075" XXX=.067"	25 dBi	9.25°	11.48°	Circular Waveguide, UG-387/U-M Flange
262D-10/XXX/387	D-Band	100.0-112.0 112.0-125.0 125.0-140.0 140.0-170.0	XXX=.082" XXX=.075" XXX=.067" XXX=.059"	10 dBi	55.75°	55.54°	Circular Waveguide, UG-387/U-M Flange
262D-15/XXX/387	D-Band	100.0-112.0 112.0-125.0 125.0-140.0 140.0-170.0	XXX=.082" XXX=.075" XXX=.067" XXX=.059"	15 dBi	30.81°	35.41°	Circular Waveguide, UG-387/U-M Flange
262D-20/XXX/387	D-Band	100.0-112.0 112.0-125.0 125.0-140.0 140.0-170.0	XXX=.082" XXX=.075" XXX=.067" XXX=.059"	20 dBi	16.29°	19.9°	Circular Waveguide, UG-387/U-M Flange
262D-25/XXX/387	D-Band	100.0-112.0 112.0-125.0 125.0-140.0 140.0-170.0	XXX=.082" XXX=.075" XXX=.067" XXX=.059"	25 dBi	9.25°	11.48°	Circular Waveguide, UG-387/U-M Flange
262G-10/XXX/387	G-Band	140.0-170.0	XXX=.059"	10 dBi	53.09°	53.85°	Circular Waveguide, UG-387/U-M Flange
262G-15/XXX/387	G-Band	140.0-170.0	XXX=.059"	15 dBi	29.71°	34.61°	Circular Waveguide, UG-387/U-M Flange
262G-20/XXX/387	G-Band	140.0-170.0	XXX=.059"	20 dBi	16.57°	20.26°	Circular Waveguide, UG-387/U-M Flange
262G-25/XXX/387	G-Band	140.0-170.0	XXX=.059"	25 dBi	8.3°	10.17°	Circular Waveguide, UG-387/U-M Flange
262H-25/XXX/387	H-Band	170.0-325.0	XXX=.049	25 dBi	8.31°	10.2°	Circular Waveguide, UG-387/U-M Flange
262J-25/XXX/387	J-Band	170.0-325.0	XXX=.049	25 dBi	9.2°	11.42°	Circular Waveguide, UG-387/U-M Flange

263/264 Series

Wide Angle Scalar Feed Horns and Sectorial Horn Antennas

MI-WAVE®
Millimeter Wave Products Inc.

Description

Mi-Wave's 263 Series wide angle scalar feed horn, also called a choke horn, has been designed to be used in applications where wide beamwidth (55 Deg.) is required such as low F/D ratios of 0.5 and 0.4 in parabolic reflectors and offset feed applications.

- *Low VSWR*
- *Wide Beamwidths*
- *Polarization Insensitive*
- *Partial Bandwidths*



Applications

Low F/D Antennas
Surveillance Systems
Offset Feed Antennas

Model Number	Band	Frequency (GHz)	Gain (Typ)	3 dB Beamwidth (E-Plane)	3 dB Beamwidth (H-Plane)	Polarization	RF Port
263A-XX/XXX/381	Ka-Band	26.5-40	10 dB	55°	56°	Linear-Circular	Circular Waveguide or UG-381/U Flange
263A-XX/XXX/599	Ka-Band	26.5-40	10 dB	55°	56°	Linear-Circular	Circular Waveguide or UG-599/U Flange
263B-XX/XXX/383	Q-Band	33-50	10 dB	55°	56°	Linear-Circular	Circular Waveguide, UG-383/U Flange
263U-XX/XXX/383	U-Band	40-60	10 dB	55°	56°	Linear-Circular	Circular Waveguide, UG-383/U Flange
263V-XX/XXX/385	V-Band	50-75	10 dB	55°	56°	Linear-Circular	Circular Waveguide, UG-385/U Flange
263E-XX/XXX/387	E-Band	60-90	10 dB	55°	56°	Linear-Circular	Circular Waveguide, UG-387/U-M Flange
263W-XX/XXX/387	W-Band	75-110	10 dB	55°	56°	Linear-Circular	Circular Waveguide, UG-387/U-M Flange

Description

Both E plane sectorial horn antenna and H plane sectorial horn antenna configurations are useable for either vertical or horizontally polarized applications and provide the maximum beam width in the un-flared dimension. Units we offer are true sectorial horn antenna parallel side designs. Only one waveguide dimension is flared with the other sides of the sectorial horn antenna remaining parallel. This makes for the large fan type coverage in the un-flared plane and a considerably narrower beam in the other plane. Antennas are available in both E and H plane configurations for rectangular waveguide.

- *Low VSWR*
- *Wide Beamwidths*
- *Polarization Insensitive*
- *Partial Bandwidths*

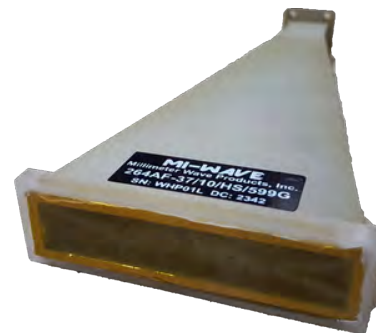

Please contact us with your specifications to discuss your sectorial horn antenna requirements with one of our RF design engineers.

Model Number	Band	Frequency (GHz)	Gain (Typ)	3 dB Beamwidth (E-Plane)	3 dB Beamwidth (H-Plane)	RF Port
264AF-XX/YY/599	Ka-Band	26.5-40	TBD	XX	YY	WR-28 Waveguide UG-599/U Flange
264BF-XX/YY/383	Q-Band	33-50	TBD	XX	YY	WR-22 Waveguide UG-383/U Flange
264UF-XX/YY/383	U-Band	40-60	TBD	XX	YY	WR-19 Waveguide UG-383/U-M Flange
264VF-XX/YY/385	V-Band	50-75	TBD	XX	YY	WR-15 Waveguide UG-385/U Flange
264EF-XX/YY/387	E-Band	60-90	TBD	XX	YY	WR-12 Waveguide UG-387/U Flange
264WF-XX/YY/387	W-Band	75-110	TBD	XX	YY	WR-10 Waveguide UG-387/U-M Flange

265 Series

Dual Ridge Horn Antennas

MI-WAVE®
Millimeter Wave Products Inc.

Description

Mi-Wave's 265 Series Dual Ridged Horn Antennas Broadband Horn Antenna 7 to 70 GHz nominal are fabricated with very close tolerances to ensure the precision of every horn manufactured by MiWave

Features

- Available from 7 to 70 GHz
- Made with precise dimensional tolerance control
- Gain calibration is accurate to 0.5 dB over full bandwidth

Applications

- Surveillance Systems
- Test and Measurement



Model Number	Frequency (GHz)	Gain (Typ)	Polarization	3dB Beamwidth (E-Plane)	3dB Beamwidth (H-Plane)	Return Loss	Port
265-7/70/1.85mmF	7-70	12 dBi	Linear	34°	32°	20 dB	1.85mm Female
265-17.7/31/1.85mmF	17.7-32	12 dBi	Linear	34°	32°	15 dB	1.85mm Female

267 Series

Omni-Directional Antennas

MI-WAVE®

Millimeter Wave Products Inc.

Description

Mi-Wave's 267 Series Omni-directional Antennas have been designed to be used in wide angle applications.

Please consult Mi-Wave for other available beamwidths.

Applications

Surveillance
 Network Broadcast and Receiving Systems
 RF Probes

- 7 to 170 GHz Available
- Low VSWR
- Wide Bandwidths
- 360 degree Azimuth Beamwidths
- "45° Vertical Beamwidth Typical
- Gain 2-3 dB Typical
- Broadband



Model Number	Band	Frequency (GHz)	Azimuth Beamwidth	Vertical Beamwidth	Power Handling (CW)	Gain (Typ)	Polarization	RF Ports
267X/SMAF	X-Band	8.2-12.4	360°	45°	5W	3 to 4 dB	Vertical	SMA-Female Connector
267Ku/SMAF	Ku-Band	12-18	360°	45°	5W	3 to 4 dB	Vertical	SMA-Female Connector
267K/595	K-Band	18-26.5	360°	45°	5W	3 to 4 dB	Vertical	WR-42 Waveguide, UG-595/U Flange
267A/599	Ka-Band	26.5-40	360°	45°	5W	3 to 4 dB	Vertical	WR-28 Waveguide, UG-599/U Flange
267B/383	Q-Band	33-50	360°	45°	5W	3 to 4 dB	Vertical	WR-22 Waveguide, UG-383/U Flange
267U/383	U-Band	40-60	360°	45°	5W	3 to 4 dB	Vertical	WR-19 Waveguide, UG-383/U-M Flange
267V/385	V-Band	50-75	360°	45°	3W	3 to 4 dB	Vertical	WR-15 Waveguide, UG-385/U Flange
267E/387	E-Band	60-90	360°	45°	2W	3 to 4 dB	Vertical	WR-12 Waveguide, UG-387/U Flange
267W/387	W-Band	75-110	360°	45°	1W	3 to 4 dB	Vertical	WR-10 Waveguide, UG-387/U-M Flange
267D/387	D-Band	110-170	360°	45°	0.01W	3 to 4 dB	Vertical	WR-06 Waveguide, UG-387/U-M Flange
267-7/70/1.85mmF	Broadband	7-70	360°	45°	W	0 dB	Vertical	1.85 mm Female Connector
267-7/40/KF	Broadband	7-40	360°	45°	W	0 dB	Vertical	2.92mm (K) Female Connector

268 Series

Scalar Feed Horns

MI-WAVE®
Millimeter Wave Products Inc.

Description

Mi-Wave's 268 Series Scalar feed horn has been designed to be used in lens illumination such as scalar lens antennas and Cassegrain antennas. Low sidelobes are inherent in this type of feed.

Please consult Mi-Wave for other available Gain and beamwidths.

- 8.2 to 110 GHz Available
- Low VSWR
- Wide Bandwidths
- Narrow Beamwidths
- Polarization Insensitive

Applications

Feeds for Scalar Lens and Cassegrain Antennas



Model Number	Band	Frequency (GHz)	Circular WG Internal Diameter	Gain (Typ)	3 dB Beamwidth (E Plane)	3 dB Beamwidth (H Plane)	Polarization	VSWR (Typ)	RF Port
268X-XX/XXX/39 268X-XX/39	X-Band	8.2-9.97 8.5-11.6 9.97-12.4	XXX=1.094" XXX=.938" XXX=.797"	15 dB	22°	26°	Linear and Circular	1.5:1	Circular Waveguide, UG-39/U Flange or WR-90 with UG-39/U Flange
268Ku-XX/XXX/419 268Ku-XX/419	Ku-Band	12.4-14.6 14.6-18	XXX=.660" XXX=.550"	15 dB	22°	26°	Linear and Circular	1.5:1	Circular Waveguide, UG-419/U Flange or WR-62 with UG-419/U Flange
268K-XX/XXX/595 268K-XX/595	K-Band	18-20.5 20.4-24.5 24.5-26.5	XXX=.470" XXX=.396" XXX=.328"	15 dB	22°	26°	Linear and Circular	1.5:1	Circular Waveguide, UG-595/U Flange or WR-42 Waveguide, UG-595/U Flange
268A-XX/XXX/599 268A-XX/599	Ka-Band	26.5-28.5 28.5-33.0 33.0-38.5 38.5-40.0	XXX=.328" XXX=.281" XXX=.250" XXX=.219"	15 dB	22°	26°	Linear and Circular	1.5:1	Circular Waveguide, UG-599/U Flange
268B-XX/XXX/383 268B-XX/383	Q-Band	33.0-38.5 38.5-43.0 43.0-50.0	XXX=.250" XXX=.219" XXX=.188"	15 dB	22°	26°	Linear and Circular	1.5:1	Circular Waveguide, UG-383/U Flange
268U-XX/XXX/383 268U-XX/383	U-band	38.5-43.0 43.0-50.0 50.0-58.0 58.0-60.0	XXX=.219" XXX=.188" XXX=.165" XXX=.141"	15 dB	22°	26°	Linear and Circular	1.5:1	Circular Waveguide, UG-383/U-M Flange
268V-XX/XXX/385 268V-XX/385	V-band	50.0-58.0 58.0-68.0 68.0-75.0	XXX=.165" XXX=.141" XXX=.125"	15 dB	22°	26°	Linear and Circular	1.5:1	Circular Waveguide, UG-385/U Flange
268E-XX/XXX/387 268V-XX/387	E-band	60.0-68.0 68.0-77.0 77.0-87.0 87.0-90.0	XXX=.141" XXX=.125" XXX=.110" XXX=.094"	15 dB	22°	26°	Linear and Circular	1.5:1	Circular Waveguide, UG-387/U Flange
268W-XX/XXX/387 268W-XX/387	W-band	75.0-77.0 77.0-87.0 87.0-100.0 100.0-110.0	XXX=.125" XXX=.110" XXX=.094" XXX=.082"	15 dB	22°	26°	Linear and Circular	1.5:1	Circular Waveguide, UG-387/U-M Flange

281 Series

Orthomode Transducers

MI-WAVE®

Millimeter Wave Products Inc.



Description

Mi-Wave's 281 Series Orthomode Transducer couples two orthogonal linearly polarized signals simultaneously while providing polarization Isolation between transmit and receive.

Features

- *VSWR (Typ) 1.2:1 typical*
- *Isolation > 30 dB typical*
- *Available from 8.2 to 220 GHz.*

Applications

The 281 Series used primarily in conjunction with the antenna product line, which can be combined with cassegrain, horn lens, or circular horn antennas to provide dual linear orthogonal/dual circular orthogonal polarization.

Model Number	Band	Frequency (GHz)	ID Circular Waveguide	Bandwidth (GHz)	Isolation (H to V)	Cross Polarization (Port)	Waveguide
281X-XX/.XXX	X-Band	8.2-9.97 8.5-11.6 9.97-12.4	1.094" .938" .797"	1.5 dB	35 dB	(H to A): 30 (V to A): 30	WR-90 Waveguide with UG-39/U Flange
281Ku-XX/.XXX/419	Ku-Band	12.4-14.6 14.6-18	.660" .550"	2 dB	35 dB	(H to A): 30 (V to A): 30	WR-62 Waveguide with UG-419/U Flange
281K-XX/.XXX/595	K-Band	18-20.5 20.4-24.5 24.5-26.5	.470" .396" .328"	3 dB	35 dB	(H to A): 30 (V to A): 30	WR-42 Waveguide with UG-595/U Flange
281A-XX/.XXX/599	Ka-Band	26.5-28.5 28.5-33.0 33.0-38.5 38.5-40.0	.328" .281" .250" .219"	5.5 dB	35 dB	(H to A): 30 (V to A): 30	WR-28 Waveguide with UG-599/U Flange
281B-XX/.XXX/383	Q-Band	33.0-38.5 38.5-43.0 43.0-50.0	.281" .250" .188"	4 dB	30 dB	(H to A): 30 (V to A): 30	WR-22 Waveguide with UG-383/U Flange
281U-XX/.XXX/383	U-Band	38.5-43.0 43.0-50.0 50.0-58.0 58.0-60.0	.328" .281" .250" .219"	5 dB	30 dB	(H to A): 30 (V to A): 30	WR-19 Waveguide with UG-383/U-M Flange
281V-XX/.XXX/385	V-Band	50.0-58.0 58.0-68.0 68.0-75.0	.165" .141" .125"	5 dB	30 dB	(H to A): 30 (V to A): 30	WR-15 Waveguide with UG-385/U Flange
281E-XX/.XXX/387	E-Band	60.0-68.0 68.0-77.0 77.0-87.0 87.0-90.0	.141" .125" .110" .094"	6 dB	30 dB	(H to A): 30 (V to A): 30	WR-12 Waveguide with UG-387/U Flange
281W-XX/.XXX/387	W-Band	75.0-77.0 77.0-87.0 87.0-100.0 100.0-110.0	.125" .110" .094" .082"	6 dB	30 dB	(H to A): 30 (V to A): 30	WR-10 Waveguide with UG-387/U-M Flange
281F-XX/.XXX/387	F-Band	87.0-100.0 100.0-112.0 112.0-125.0 125.0-140.0	.094" .082" .075" .067"	6 dB	25 dB	(H to A): 30 (V to A): 30	WR-8 Waveguide with UG-387/U-M Flange
281D-XX/.XXX/387	D-Band	100.0-112.0 112.0-125.0 125.0-140.0 140.0-170.0	.082" .075" .067" .059"	7 dB	25 dB	(H to A): 30 (V to A): 30	WR-6 Waveguide with UG-387/U-M Flange
281G-XX/.XXX/387	G-Band	125-140 140-220	.067" .059"	7 dB	20 dB	(H to A): 30 (V to A): 30	WR-5 Waveguide with UG-387/U-M Flange

282 Series

Circular Polarizers

MI-WAVE®

Millimeter Wave Products Inc.

Description

Mi-Wave's 282 Series circular polarizer converts input linear signals to circularly polarized output signals. The circular polarization sense (RHCP or LHCP) and center frequency should be specified at the time of order. This polarizer will yield a maximum VSWR of 1.2 an axial ratio of 1.0 dB maximum over the indicated bandwidth. Reversing the input/output ports will convert circularly polarized signals to linearly polarized signals

- *VSWR < 1.2*
- *Higher Frequency Units will be quoted on request.*
- *Axial Ratio < 1.0 dB Over the indicated bandwidth.*
- *Converts Linear/Circular Input Signals to RHCP or LHCP*
- *Specify Sense of Circular Polarization (RHCP or LHCP)*
- *Available from 8.2 to 220 GHz. with 3% or Greater Bandwidth.*



Applications

- Satellite Links
- Radio Astronomy
- Communications Systems

Model Number	Band	Frequency (GHz)	ID Circular Waveguide	Insertion Loss (Typ)	Bandwidth	Axial Ratio	Waveguide
282X-XX/XXX/90	X-Band	8.2-9.97 8.5-11.6 9.97-12.4	1.094" .938" .797"	0.3 dB	2	1 dB	UG-90/U Flange
282Ku-XX/XXX/90	Ku-Band	12.4-14.6 14.6-18	.660" .550"	0.5 dB	2.2	1 dB	UG-419/U Flange
282K-XX/XXX/595	K-Band	18-20.5 20.4-24.5 24.5-26.5	.470" .396" .328"	0.5 dB	3	1 dB	UG-595/U Flange
282A-XX/XXX/599	Ka-Band	26.5-28.5 28.5-33.0 33.0-38.5 38.5-40.0	.328" .281" .250" .219"	0.5 dB	5	1 dB	UG-599/U Flange
282B-XX/XXX/383	Q-Band	33.0-38.5 38.5-43.0 43.0-50.0	.281" .250" .188"	0.7 dB	5	1 dB	UG-383/U Flange
282U-XX/XXX/383	U-Band	38.5-43.0 43.0-50.0 50.0-58.0 58.0-60.0	.328" .281" .250" .219"	0.7 dB	6	1 dB	UG-383/U Flange-M
282V-XX/XXX/385	V-Band	50.0-58.0 58.0-68.0 68.0-75.0	.165" .141" .125"	0.8 dB	7	1 dB	UG-385/U Flange
282E-XX/XXX/387	E-Band	60.0-68.0 68.0-77.0 77.0-87.0 87.0-90.0	.141" .125" .110" .094"	1 dB	7	1 dB	UG-387/U Flange
282W-XX/XXX/387	W-Band	75.0-77.0 77.0-87.0 87.0-100.0 100.0-110.0	.125" .110" .094" .082"	1 dB	8	1 dB	UG-387/U Flange-M
282F-XX/XXX/38	F-Band	87.0-100.0 100.0-112.0 112.0-125.0 125.0-140.0	.094" .082" .075" .067"	1.2 dB	10	1 dB	UG-387/U Flange-M
282D-XX/XXX/387	D-Band	100.0-112.0 112.0-125.0 125.0-140.0 140.0-170.0	.082" .075" .067" .059"	1.5 dB	10	1 dB	UG-387/U Flange-M
282G-XX/XXX/387	G-Band	125-140 140-220	.067" .059"	1.7 dB	10	1 dB	UG-387/U Flange-M

283 Series

Linear-circular Switchable Polarizers

MI-WAVE®
Millimeter Wave Products Inc.



Description

Mi-Wave's 283 Series Polarizer, similar to the 282 Series, will convert linear input signals to circular output signals with selectable output features. A manual switch on the unit allows for selection of the output signal's polarization sense or conversion back to a linear polarization. Therefore, for any linearly polarized input signal, the output may be selected to be right circular, left circular or linear polarization.

Features

- *VSWR < 1.2*
- *Extremely Compact*
- *Manual Switch for Polarization Selection*

Applications

- *Axial Ratio < 1.0 dB over the indicated bandwidth.*
- *Available from 8.2 to 220 GHz*
- Radio Astronomy
- Communication Links
- Communication Systems

Model Number	Band	Frequency (GHz)	ID Circular Waveguide	Insertion Loss (Typ)	Bandwidth	Axial Ratio	Waveguide
282X-XX/XXX/90	X-Band	8.2-9.97 8.5-11.6 9.97-12.4	.1094" .938" .797"	0.3 dB	2	1 dB	UG-90/U Flange
282Ku-XX/XXX/90	Ku-Band	12.4-14.6 14.6-18	.660" .550"	0.5 dB	2.2	1 dB	UG-419/U Flange
282K-XX/XXX/595	K-Band	18-20.5 20.4-24.5 24.5-26.5	.470" .396" .328"	0.5 dB	3	1 dB	UG-595/U Flange
282A-XX/XXX/599	Ka-Band	26.5-28.5 28.5-33.0 33.0-38.5 38.5-40.0	.328" .281" .250" .219"	0.5 dB	5	1 dB	UG-599/U Flange
282B-XX/XXX/383	Q-Band	33.0-38.5 38.5-43.0 43.0-50.0	.281" .250" .188"	0.5 dB	5	1 dB	UG-383/U Flange
282U-XX/XXX/383	U-Band	38.5-43.0 43.0-50.0 50.0-58.0 58.0-60.0	.328" .281" .250" .219"	0.7 dB	6	1 dB	UG-383/U Flange-M
282V-XX/XXX/385	V-Band	50.0-58.0 58.0-68.0 68.0-75.0	.165" .141" .125"	0.8 dB	7	1 dB	UG-385/U Flange
282E-XX/XXX/387	E-Band	60.0-68.0 68.0-77.0 77.0-87.0 87.0-90.0	.141" .125" .110" .094"	1 dB	7	1 dB	UG-387/U Flange
282W-XX/XXX/387	W-Band	75.0-77.0 77.0-87.0 87.0-100.0 100.0-110.0	.125" .110" .094" .082"	1 dB	8	1 dB	UG-387/U Flange-M
282F-XX/XXX/38	F-Band	87.0-100.0 100.0-112.0 112.0-125.0 125.0-140.0	.094" .082" .075" .067"	1.2 dB	10	1 dB	UG-387/U Flange-M
282D-XX/XXX/387	D-Band	100.0-112.0 112.0-125.0 125.0-140.0 140.0-170.0	.082" .075" .067" .059"	1.5 dB	10	1 dB	UG-387/U Flange-M
282G-XX/XXX/387	G-Band	125-140 140-220	.067" .059"	1.7 dB	10	1 dB	UG-387/U Flange-M

284 Series

Circular to Rectangular Waveguide Transitions Adapters

MI-WAVE®
Millimeter Wave Products Inc.

Description

Mi-Wave's 284 Series tapered mode transitions is a precision formed adapter used to transform rectangular TE10 mode waveguide to a circular TE11 mode waveguide. Mainly used in antenna systems and associated components to adapt to conventional waveguide.

- *Low Insertion Loss*
- *Precision-fabricated*
- *VSWR < 1.15 Typical*
- *Converts from rectangular TE10 Mode to Circular TE11 Mode*
- *Available from 8.2 to 325 GHz*



Applications

Antenna Systems
Orthomode Transducers
Polarization for Antennas

Model	Band	Frequency (GHz)	ID Circular Waveguide	Interface
284X-XXX/39	X-Band	8.2-9.97 8.5-11.6 9.97-12.4	1.094" .938" .797"	UG-90/U Flange
284Ku-XXX/419	Ku-Band	12.4-14.6 14.6-18	.660" .550"	UG-419/U Flange
284K-XXX/595	K-Band	18-20.5 20.4-24.5 24.5-26.5	.470" .396" .328"	UG-595/U Flange
284A-XXX/599	Ka-Band	26.5-28.5 28.5-33.0 33.0-38.5 38.5-40.0	.328" .281" .250" .219"	UG-599/U Flange
284B-XXX/383	Q-Band	33.0-38.5 38.5-43.0 43.0-50.0	.281" .250" .188"	UG-383/U Flange
284U-XXX/383	U-Band	38.5-43.0 43.0-50.0 50.0-58.0 58.0-60.0	.328" .281" .250" .219"	UG-383/U Flange-M
284V-XXX/385	V-Band	50.0-58.0 58.0-68.0 68.0-75.0	.165" .141" .125"	UG-385/U Flange
284E-XXX/387	E-Band	60.0-68.0 68.0-77.0 77.0-87.0 87.0-90.0	.141" .125" .110" .094"	UG-387/U Flange
284W-XXX/387	W-Band	75.0-77.0 77.0-87.0 87.0-100.0 100.0-110.0	.125" .110" .094" .082"	UG-387/U Flange-M
284F-XXX/387	F-Band	87.0-100.0 100.0-112.0 112.0-125.0 125.0-140.0	.094" .082" .075" .067"	UG-387/U Flange-M
284D-XXX/387	D-Band	100.0-112.0 112.0-125.0 125.0-140.0 140.0-170.0	.082" .075" .067" .059"	UG-387/U Flange-M
284G-XXX/387	G-Band	125-140 140-220	.067" .059"	UG-387/U Flange-M
284H-XXX/387	H-Band	170-260	1.059"	UG-387/U Flange-M
284J-XXX/387	J-Band	220-325	1.049"	UG-387/U Flange-M

410 Series

Waveguide to Coax Adapter | Right Angle Adapters

MI-WAVE®
Millimeter Wave Products Inc.



Description

Mi-Wave's 410 Series Waveguide to Coax Transitions allow an efficient method of adapting from rectangular waveguide to a coaxial Connector. Full Bands available from 8.2 to 110 GHz.

- *Low Cost Versions Available*
- *Frequency Ranges 8.2 to 110 GHz*
- *Wide Variety of Coax Connectors Available*
- *High Performance Versions for Laboratory Use.*

Low Insertion Losses and VSWR's are typical for these adapters. Low cost production versions are available for equipment used and OEM's. Laboratory grades are also offered on some models.

Applications

Test Equipment
Power Measurement

Model Number	Band	Frequency (GHz)	Insertion Loss (Typ)	Return loss (Typ)	Power Handling (CW)	Waveguide Port	Coaxial Port
410X/39/NF	X-Band	8.2-12.4	0.4 dB	16 dB	400 W	WR-90 Waveguide, UG-39/U Flange	NF- Female Connector
410X/39/SMAF	X-Band	8.2-12.4	0.4 dB	17 dB	150 W	WR-90 Waveguide, UG-39/U Flange	SMA- Female Connector
410X/39/SMAM	X-Band	8.2-12.4	0.4 dB	16 dB	150 W	WR-90 Waveguide, UG-39/U Flange	SMA-Male Connector
410(75)/SMAF	WR-75	10-15	0.3 dB	20 dB	150 W	WR-75 Waveguide	SMA Female
410Ku/419/SMAF	Ku-Band	12.4-18	0.3 dB	20 dB	150 W	WR-62 Waveguide, UG-419 Flange	SMA Female
410(51)/U BR180/CKF	WR-51	15-12	0.3 dB	20 dB	10 W	WR-51 Waveguide, UBR180 Flange	CK-Female Connector
410(34)/596/KF	WR-34	22-33	0.4 dB	20 dB	10 W	WR-34 Waveguide, UG-596 Flange	K-Female Connector
410(34)/595/KF	WR-34	22-33	0.4 dB	17 dB	10 W	WR-34 Waveguide, UG-596 Flange	K-Female Connector
410(34)/595/3.5mmF	WR-34	22-33	0.4 dB	20 dB	10 W	WR-34 Waveguide, UG-596 Flange	3.5 mm Female Connector
410K/595/SMAF	K-Band	18-26.5	0.4 dB	20 dB	150 W	WR-42 Waveguide, UG-595/U Flange	SMA-Female
410K/595/KF	K-Band	18-26.5	0.4 dB	20 dB	10 W	WR-42 Waveguide, UG-595/U Flange	K-Female Connector
410A/599/KF	Ka-Band	26.5-40	0.4 dB	20 dB	10 W	WR-28 Waveguide, UG-599/U Flange	K-Female Connector
410A/599/KM	Ka-Band	26.5-40	0.4 dB	20 dB	10 W	WR-28 Waveguide, UG-599/U Flange	K-Male Connector
410B/383/KF	Q-Band	33-40	0.5 dB	20 dB	10 W	WR-22 Waveguide, UG-383/U Flange	K-Female Connector
410B/383/KM	Q-Band	33-40	0.4 dB	20 dB	10 W	WR-22 Waveguide, UG-383/U Flange	2.92mm (K) Male Connector
410B/383/2.4mmF	Q-Band	33-50	0.4 dB	20 dB	10 W	WR-22 Waveguide, UG-383/U Flange	2.4 mm Female Connector
410B/383/2.4mmM	Q-Band	33-50	0.4 dB	20 dB	10 W	WR-22 Waveguide, UG-383/U Flange	2.4 mm Male Connector
410U/383/1.85mmF	U-Band	40-60	0.5 dB	17 dB	10 W	WR-19 Waveguide, UG-383/U-M Flange	1.85 mm Female Connector
410U/383/1.85mmM	U-Band	40-60	0.5 dB	17 dB	10 W	WR-19 Waveguide, UG-383/U-M Flange	1.85 mm Male Connector
410V/385/1.85mmF	V-Band	50-67	0.5 dB	17 dB	10 W	WR-15 Waveguide, UG-385/U Flange	1.85 mm Female Connector
410V/385/1.85mmM	V-Band	50-67	0.5 dB	17 dB	10 W	WR-15 Waveguide, UG-385/U Flange	1.85 mm Male Connector
410V/385/1.85mmF	V-Band	50-67	0.5 dB	17 dB	10 W	WR-15 Waveguide, UG-385/U Flange	1.85 mm Female Connector
410V/385/1.00mmF	V-Band	50-67	0.5 dB	15 dB	10 W	WR-15 Waveguide, UG-385/U Flange	1.00 mm Female Connector
410E/387/1.00mmM	E-Band	60-90	1 dB	15 dB	10 W	WR-12 Waveguide, UG-387/U Flange	1.85 mm Male Connector
410E/387/1.00mmF	E-Band	60-90	1 dB	15 dB	10 W	WR-12 Waveguide, UG-387/U Flange	1.00 mm Female Connector
410W/387/1.00mmM	W-Band	75-110	1.2 dB	15 dB	10 W	WR-10 Waveguide, UG-387/U-M Flange	1.00 mm Male Connector
410W/387/1.00mmF	W-Band	75-110	1.2 dB	15 dB	10 W	WR-10 Waveguide, UG-387/U-M Flange	1.00 mm Female Connector

411 Series

Waveguide to Coax Adapter | Inline Adapters

MI-WAVE®
Millimeter Wave Products Inc.



Description

Mi-Wave's 411 Series Waveguide to Coax Transitions allow an efficient method of adapting from rectangular waveguide to a in-line coaxial Connector. Full Bands available from 8.2 to 110 GHz.

Our new design and manufacturing process allows for Low Insertion Losses and VSWR's for these adapters. Low cost production versions are available for equipment used and OEM's. Laboratory grades are also offered on some models.

- *Low Cost Versions Available*
- *Frequency Ranges 8.2 to 110 GHz*
- *Full Band Units*
- *Compact Size*
- *High Performance Lab Versions*

Applications

Test Equipment
Power Measurement

1mm Connectors for WR-15, WR-12, WR-10

Model Number	Band	Frequency (GHz)	Insertion Loss (Typ)	Return loss (Typ)	Power Handling (CW)	Waveguide Port	Coaxial Port
411X/39/NF	X-Band	8.2-12.4	0.4 dB	16 dB	400 W	WR-90 Waveguide, UG-39/U Flange	NF- Female Connector
411X/39/SMAF	X-Band	8.2-12.4	0.4 dB	17 dB	150 W	WR-90 Waveguide, UG-39/U Flange	SMA- Female Connector
411X/39/SMAM	X-Band	8.2-12.4	0.4 dB	16 dB	150 W	WR-90 Waveguide, UG-39/U Flange	SMA-Male Connector
411(51)U BR180/CKF	WR-51	15-12	0.3 dB	20 dB	10 W	WR-51 Waveguide, UBR180 Flange	CK-Female Connector
411(34)/596/KF	WR-34	22-33	0.4 dB	20 dB	10 W	WR-34 Waveguide, UG-596 Flange	K-Female Connector
411(34)/595/KF	WR-34	22-33	0.4 dB	17 dB	10 W	WR-34 Waveguide, UG-596 Flange	K-Female Connector
411(34)/595/3.5mmF	WR-35	22-33	0.4 dB	20 dB	10 W	WR-34 Waveguide, UG-596 Flange	3.5 mm Female Connector
411(75)/SMAF	WR-75	10-15	0.3 dB	20 dB	150 W	WR-75 Waveguide	SMA Female
411Ku/419/SMAF	Ku-Band	12.4-18	0.3 dB	20 dB	150 W	WR-62 Waveguide, UG-419 Flange	SMA Female
411K/595/SMAF	K-Band	18-26.5	0.4 dB	20 dB	150 W	WR-42 Waveguide, UG-595/U Flange	SMA-Female
411K/595/KF	K-Band	18-26.5	0.4 dB	20 dB	10 W	WR-42 Waveguide, UG-595/U Flange	K-Female Connector
411A/599/KF	Ka-Band	26.5-40	0.4 dB	20 dB	10 W	WR-28 Waveguide, UG-599/U Flange	K-Female Connector
411A/599/KM	Ka-Band	26.5-40	0.4 dB	20 dB	10 W	WR-28 Waveguide, UG-599/U Flange	K-Male Connector
411B/383/KF	Q-Band	33-40	0.5 dB	20 dB	10 W	WR-22 Waveguide, UG-383/U Flange	K-Female Connector
411B/383/KM	Q-Band	33-40	0.4 dB	20 dB	10 W	WR-22 Waveguide, UG-383/U Flange	2.92mm (K) Male Connector
411B/383/2.4mmF	Q-Band	33-50	0.4 dB	20 dB	10 W	WR-22 Waveguide, UG-383/U Flange	2.4 mm Female Connector
411B/383/2.4mmM	Q-Band	33-50	0.4 dB	20 dB	10 W	WR-22 Waveguide, UG-383/U Flange	2.4 mm Male Connector
411U/383/1.85mmF	U-Band	40-60	0.5 dB	17 dB	10 W	WR-19 Waveguide, UG-383/U-M Flange	1.85 mm Female Connector
411U/383/1.85mmM	U-Band	40-60	0.5 dB	17 dB	10 W	WR-19 Waveguide, UG-383/U-M Flange	1.85 mm Male Connector
411V/385/1.85mmF	V-Band	50-67	0.5 dB	17 dB	10 W	WR-15 Waveguide, UG-385/U Flange	1.85 mm Female Connector
411V/385/1.85mmM	V-Band	50-67	0.5 dB	17 dB	10 W	WR-15 Waveguide, UG-385/U Flange	1.85 mm Male Connector
411V/385/1.85mmF	V-Band	50-67	0.5 dB	17 dB	10 W	WR-15 Waveguide, UG-385/U Flange	1.85 mm Female Connector
411V/385/1.00mmF	V-Band	50-67	0.5 dB	15 dB	10 W	WR-15 Waveguide, UG-385/U Flange	1.00 mm Female Connector
411E/387/1.00mmM	E-Band	60-90	1 dB	15 dB	10 W	WR-12 Waveguide, UG-387/U Flange	1.85 mm Male Connector
411E/387/1.00mmF	E-Band	60-90	1 dB	15 dB	10 W	WR-12 Waveguide, UG-387/U Flange	1.00 mm Female Connector
411W/387/1.00mmM	W-Band	75-110	1.2 dB	15 dB	10 W	WR-10 Waveguide, UG-387/U-M Flange	1.00 mm Male Connector
411W/387/1.00mmF	W-Band	75-110	1.2 dB	15 dB	10 W	WR-10 Waveguide, UG-387/U-M Flange	1.00 mm Female Connector

450 Series

High Pass Filters

MI-WAVE®

Millimeter Wave Products Inc.



Description

Mi-Wave's 450 Series High Pass Filters use a simple yet effective waveguide cut-off filter technique. This design is useful for eliminating unwanted side bands in up-converters and out-of-band frequencies in communication systems. These filters are small in size and compact by design. The 450 Series can be designed for any frequency range from 12.4 to 325 GHz. Low Insertion Losses from 0.15 dB and cut off Rejections of up to 80 dB are possible. Consult Mi-Wave for dimensions due to the wide ranged of waveguide sizes and frequency ranges.

- *Low Cost*
- *Wide Bandwidths*
- *Low Insertion Loss*
- *Low VSWR in Band*

Applications

Side Band Filters
 Frequency Diplexers
 Telecommunications Systems

Min Passband Frequency	Passband Insertion Loss	Min Rejection Frequency	Max Rejection Frequency	Rejection	Waveguide Port
26.5 GHz	1.0 dB	DC	86Ghz	40dB	WR-10 Waveguide
29 GHz	1.0 dB	DC	84Ghz	40dB	WR-10 Waveguide
30 GHz	0.9 dB	DC	80Ghz	40dB	WR-10 Waveguide
34 GHz	1.0 dB	DC	80Ghz	40dB	WR-10 Waveguide
35.5 GHz	1.0 dB	DC	77Ghz	40dB	WR-12 Waveguide
50 GHz	1.0 dB	DC	82Ghz	40dB	WR-10 Waveguide
57 GHz	1.0 dB	DC	70Ghz	40dB	WR-10 Waveguide
57 GHz	0.8 dB	DC	67Ghz	40dB	WR-12 Waveguide
57 GHz	0.5 dB	DC	66Ghz	40dB	WR-12 Waveguide
60 GHz	1.0 dB	DC	65Ghz	40dB	WR-12 Waveguide
63 GHz	0.8 dB	DC	53Ghz	40dB	WR-12 Waveguide
63 GHz	1.0 dB	DC	55Ghz	40dB	WR-12 Waveguide
67 GHz	0.8 dB	DC	59Ghz	40dB	WR-12 Waveguide
70 GHz	1.0 dB	DC	71Ghz	40dB	WR-15 Waveguide
71 GHz	1.0 dB	DC	57Ghz	40dB	WR-15 Waveguide
75 GHz	0.8 dB	DC	53Ghz	40dB	WR-15 Waveguide
75 GHz	1.0 dB	DC	56Ghz	20dB	WR-15 Waveguide
81 GHz	1.0 dB	DC	46Ghz	40dB	WR-15 Waveguide
82 GHz	1.0 dB	DC	30.5Ghz	30dB	WR-22 Waveguide
84 GHz	2.0 dB	DC	31Ghz	40dB	WR-22 Waveguide
86 GHz	.5 dB	DC	26Ghz	40dB	WR-28 Waveguide
90 GHz	.5 dB	DC	25Ghz	40dB	WR-28 Waveguide
92 GHz	.5 dB	DC	22.5Ghz	40dB	WR-28 Waveguide
104 GHz	2.5 dB	DC	126Ghz	80dB	WR-06 Waveguide
130 GHz	2.5 dB	DC	100Ghz	40dB	WR-08 Waveguide

460 Series

Band Pass Filters

MI-WAVE®
Millimeter Wave Products Inc.

Description

Mi-Wave's 460 Series Band Pass Filters are used for narrow and wide band applications. Pass bands are typically from 1% to 10%. This design is well suited for frequency diplexers used in communication systems or any application where narrow bandwidths are required.

- *Low VSWR*
- *Narrow Bandwidths*
- *High Rejection levels*
- *Low In-band Insertion*

Insertion Losses are typically in the 0.8 dB to 2.0 dB area depending upon Rejection levels. The 460 Series Band pass filter can be designed from 8 to 140GHz.

Custom designs available, send us your requirements

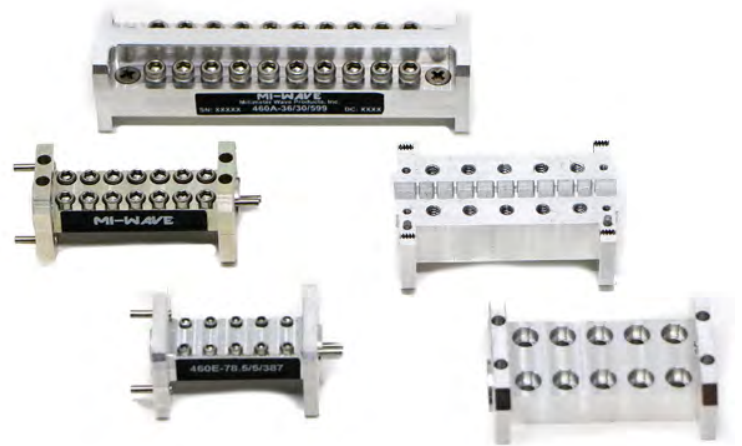

Model	Passband Frequency	Rejection Frequencies	Waveguide Port
460A-26.5/KF	23-30 GHz	55 dBc at 38.25 GHz, 55 dBc at 42 GHz, 55 dBc at 70 GHz	K-Female Connector
460A-35/7/KF	31.5-38.5 GHz	65 dBc at 21 GHz, 35 dBc at 30 GHz, 35 dBc at 40 GHz, 65 dBc at 49 GHz, 65 dBc at 90 GHz	K-Female Connector
460A-24/28/599	24-28 GHz	55 dBc at 23.5 GHz, 30 dBc at 29.4 GHz	WR-28 Waveguide Flange UG-599/U
460A-27/28.5/K	27-28.5 GHz	32 dBc at 26 GHz, 29 dBc at 29 GHz	K-Female Connector
460A-23/31/KF	23-31 GHz	34 dBc at 22 GHz, 33 dBc at 33 GHz	K-Female Connector
460B-44.5/719	43-46 GHz	30 dBc 41 GHz and 49 GHz	WR-22 Waveguide, UG-719/U Flange
460U-43/383	40-50 GHz	-55dBc at DC to 34 GHz and at >52 GHz	WR-19 Waveguide, UG-/383U Flange
460U-47/383	45.3-50.3 GHz	-50 dBc at 43.8 GHz and at 51.8 GHz	WR-19 Waveguide, UG-/383U Flange
460U-46.5/50.3/383	45.3-50.3 GHz	-50 dBc at 43.8 GHz and at 51.8 GHz	WR-19 Waveguide, UG-/383U Flange
460U-48/383	42-54 GHz	-40 dBc at 43.8 GHz and at 51.8 GHz	WR-19 Waveguide, UG-/383U Flange
460U-49/383	47-52 GHz	25 dBc at 46 GHz, 30 dBc at 53 GHz	WR-19 Waveguide, UG-/383U Flange
460U-50.9/383	49-54.5 GHz	>-50 dBc at DC to 48 GHz and at >56 GHz	WR-19 Waveguide, UG-/383U Flange
460U-52/383	49.5-54.6 GHz	>-50 dBc at DC to 50 GHz and at >56 GHz	WR-19 Waveguide, UG-/383U Flange
460U-55/383	53.5-56.5 GHz	-60 dBc at DC to 52 GHz and at >58 GHz	WR-19 Waveguide, UG-/383U Flange
460U-58/383	57.5-58.5 GHz	-55 dBc at 56.5 GHz and at 59.5 GHz	WR-19 Waveguide, UG-/383U Flange
460V-54.5/56.5/385	54.5-56.5 GHz	50 dBc at +/- 2 GHz from Passband	WR-15 Waveguide, UG-385/U Flange
460V-64/14/385	57-71 GHz	50 dBc at 53.28 GHz and Below	WR-15 Waveguide, UG-385/U Flange
460V-65/20/385	55-75 GHz	50 dBc at 50 GHz and at 80 GHz	WR-15 Waveguide, UG-385/U Flange
460E-62.8/387	60.8-64.8 GHz	30 dBc at 59.8 GHz and at 65.8 GHz	WR-12 Waveguide, UG-387/U-M Flange
460E-74.5/82.5/40/387	74.5-82.5 GHz	50 dBc at DC-71.5 GHz and at 85.5-105	WR-12 Waveguide, UG-387/U-M Flange
460E-60.8/64.8/387	60.8-64.8 GHz	30 dBc at 60 GHz, 30.5 dBc at 65 GHz	WR-12 Waveguide, UG-387/U-M Flange
460E-79/81/387	79-81 GHz	33.5 dBc at 78 GHz, 32 dBc at 81 GHz	WR-12 Waveguide, UG-387/U-M Flange
460E-75/83/50/387	75-83 GHz	50.6 dBc at 73.5 GHz, 50.8 dBc at 84.8 GHz	WR-12 Waveguide, UG-387/U-M Flange
460E-63.5/82.5/387	63.5-82.5 GHz	30.5 dBc at 61.75 GHz, 31.7 dBc at 84 GHz	WR-12 Waveguide, UG-387/U-M Flange
460E-76.5/81/387	76.5-81 GHz	33.6 dBc at 75 GHz, 32.4 dBc at 82 GHz	WR-12 Waveguide, UG-387/U-M Flange
460E-76.5/81.5/387	76.5-81.5 GHz	31.7 dBc at 75 GHz, 30.8 dBc at 82 GHz	WR-12 Waveguide, UG-387/U-M Flange
460E-76/81/387	76-81 GHz	31.8 dBc at 75 GHz, 32 dBc at 81.9 GHz	WR-12 Waveguide, UG-387/U-M Flange
460E-75/83/387	75-83 GHz	33.4 dBc at 73 GHz, 31.5 dBc at 84 GHz	WR-12 Waveguide, UG-387/U-M Flange
460E-75.5/81/387	75-81 GHz	31.9 dBc at 74 GHz, 31.7 dBc at 82 GHz	WR-12 Waveguide, UG-387/U-M Flange
460W-84/387	82.5-85.5 GHz	50 dBc at DC-79 GHz and at 93.5-110 GHz	WR-10 Waveguide, UG-387/U Flange
460W-92.5/387	90-95 GHz	50 dBc at DC-86 GHz and at 101-110 GHz	WR-10 Waveguide, UG-387/U Flange
460W-100/387	98-102 GHz	-60 dBc at DC-95 GHz, -50 dBc at 105-110 GHz	WR-10 Waveguide, UG-387/U Flange
460W-105/40/387	100-110 GHz	-45 dBc at 98 GHz and at 112 GHz	WR-10 Waveguide, UG-387/U Flange

470 Series

Low Pass Filters

MI-WAVE®
Millimeter Wave Products Inc.

Description

Mi-Wave's 470 Series Low Pass Filters use a simple yet effective waveguide cut-off filter technique. This design is useful for eliminating unwanted side bands in down-converters and out-of-band frequencies in communication systems.

- *Low Cost*
- *Low VSWR*
- *Narrow Bandwidths*
- *High Rejection levels*

These filters are small in size and compact by design. The 470 Series can be designed for any frequency range from 12.4 to 325 GHz. Low Insertion Losses from 0.15 dB and cut off Rejections of up to 80 dB are possible.

Consult Mi-Wave for dimensions due to the wide ranged of waveguide sizes and frequency ranges.

Applications

Side Band Filters
Frequency Diplexers
Telecommunications Systems

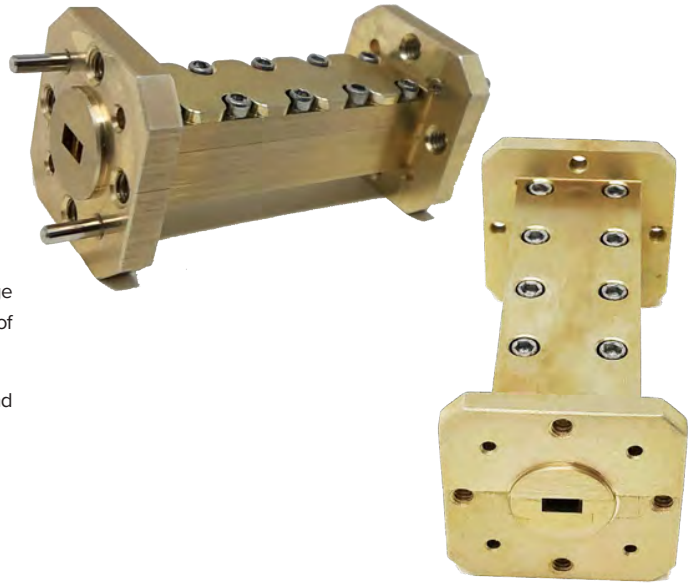

Passband Frequency	Passband Insertion Loss	Rejection Frequency (Low Side)	Rejection Frequency (High Side)	Rejection	Waveguide Port
10-15Ghz	15Ghz	DC-8Ghz	18-25GHz	40dB	WR-75 Waveguide
15-22Ghz	22Ghz	DC-12Ghz	25-40GHz	40dB	WR-51 Waveguide
22-32Ghz	32Ghz	DC-17Ghz	37-75GHz	40dB	WR-28 Waveguide
22-34Ghz	34Ghz	DC-21Ghz	37-67GHz	40dB	WR-28 Waveguide
22-34Ghz	34Ghz	DC-20Ghz	37-70GHz	40dB	WR-28 Waveguide
22-35Ghz	35Ghz	DC-20Ghz	40-72GHz	40dB	WR-28 Waveguide
26-60Ghz	60Ghz	DC-20Ghz	90-140GHz	50dB	WR-28 Waveguide
26.5-40Ghz	40Ghz	DC-21Ghz	48-90GHz	60dB	WR-28 Waveguide
30-50Ghz	50Ghz	DC-25Ghz	56-100GHz	40dB	WR-22 Waveguide
50-75Ghz	75Ghz	DC-48Ghz	79-110GHz	40dB	WR-12 Waveguide
50-75Ghz	75Ghz	DC-40Ghz	79-120GHz	40dB	WR-15 Waveguide
50-84Ghz	84Ghz	DC-48Ghz	87-110GHz	40dB	WR-12 Waveguide
50-90Ghz	90Ghz	DC-45Ghz	95-140GHz	40dB	WR-12 Waveguide
62-110Ghz	110Ghz	DC-56Ghz	120-160GHz	50dB	WR-10 Waveguide
62-90Ghz	90Ghz	DC-59Ghz	92-140GHz	80dB	WR-10 Waveguide

510 Series

Direct Reading Precision Attenuators

MI-WAVE®
Millimeter Wave Products Inc.



Description

Mi-Wave's 510 Series Direct-reading Precision Attenuators provide 0 to 60 dB of calibrated attenuation by rotation of a resistive vane mounted in a circular waveguide section. These units are often referred to as "precision rotary vane attenuators."

- *Low VSWR*
- *Direct Reading*
- *Low Insertion Loss*
- *Anti-backlash Drive*
- *Negligible Phase Shift*
- *Precision Construction*
- *Frequency Independent*

Applications

The 510 Series Direct-reading Precision attenuators are used in all RF measurement systems. They are most frequently used in RF substitution-type set-ups for precise measurement of characteristics such as Isolation, Coupling, Insertion Loss, and Gain.

Accuracy .1 dB or $\pm 3\%$ of reading typical flatness $\pm 5\%$ of reading

Model Number	Band	Frequency (GHz)	Insertion Loss (Typ)	Attenuation Range	Power Handling (CW)	RF Ports
510X/UBR120	X-Band	8.2-12.4	0.5 dB	0-50 dB	2 Watts	WR-90 Waveguide, UG-39/U Flange
510Ku/419	Ku-Band	12.4-18	0.5 dB	0-60 dB	1 Watts	WR-62 Waveguide, UG-419 Flange
510K/595	K-Band	18-26.5	0.5 dB	0-60 dB	1 Watts	WR-42 Waveguide, UG-595/U Flange
510(34)/1530	WR-34	22-33	0.5 dB	0-60 dB	1 Watts	WR-34 Waveguide, UG-595 Flange
510A/599	Ka-Band	26.5-40	0.6 dB	0-60 dB	1 Watts	WR-28 Waveguide, UG-599/U Flange
510B/383	Q-Band	33-50	0.7 dB	0-60 dB	0.5 Watts	WR-22 Waveguide, UG-383/U Flange
510U/383	U-Band	40-60	0.7 dB	0-60 dB	0.5 Watts	WR-19 Waveguide, UG-383/U-M Flange
510V/385	V-Band	50-75	1.2 dB	0-60 dB	0.5 Watts	WR-15 Waveguide, UG-385/U Flange
510E/387	E-Band	60-90	1.5 dB	0-60 dB	0.2 Watts	WR-12 Waveguide, UG-387/U-M Flange
510W/387	W-Band	75-110	1.7 dB	0-60 dB	0.2 Watts	WR-10 Waveguide, UG-387/U-M Flange
510F/387	F-Band	90-140	2.0 dB	0-50 dB	0.1 Watts	WR-8 Waveguide, UG-387/U-M Flange
510D/387	D-Band	110-170	3.0 dB	0-50 dB	0.1 Watts	WR-6 Waveguide, UG-387/U-M Flange
510G/387	G-Band	140-220	3.8 dB	0-40 dB	0.1 Watts	WR-5 Waveguide, UG-387/U-M Flange
510H-387	H-Band	170-260	6 dB	0-40 dB	0.1 Watts	WR-4 Waveguide, UG-387/U-M Flange
510J/387	J-Band	220-325	7 dB	0-40 dB	0.05 Watts	WR-03 Waveguide, UG-387/U-M Flange

511 Series

Programmable Rotary Vane Attenuators

MI-WAVE®
Millimeter Wave Products Inc.

Description

Mi-Wave's 511 Series Precision Programmable Rotary Vane Attenuators are available in full Bands from 8.2 to 325 GHz. Attenuation control is performed manually via a front panel or remote-controlled using a standard IEEE-488 or USB interface.

The attenuator's small compact size incorporates both the electronic controller and the microwave components. The unit operates from a single +24 Volt DC source or with an optional adapter.

The attenuation range is from 0 to 70 dB in .01 dB steps. 0-20 dB

A digital readout is provided on the front panel to display attenuation settings. USB GPIB interface is available. Tested to over 1 million cycles New company proprietary internal absorbing material that will handle high power levels and yield Low Insertion Loss and mode-free operation to 60 dB attenuation levels.

Accuracy .1 dB or $\pm 2\%$ of reading typical flatness $\pm 5\%$ of reading

Applications

- Fade Margin Testing of Microwave Radios
- Remote Control of RF Power Levels
- Fade Margin Testing of Microwave Radio Equipment
- Instrumentation

- *Low Cost*
- *Compact Size*
- *8.2 to 325 GHz.*
- *High Accuracy*
- *Highly Reliable*
- *Digital Readout*
- *Low Insertion Loss*
- *IEEE-488 USB Interface*
- *Full Bands*
- *Manual Operation Mode*



Model Number	Band	Frequency (GHz)	Insertion Loss (Typ)	Attenuation Range	Power Handling (CW)	Resolution	RF Ports
511X/39ND	X-Band	8.2-12.4	0.5 dB	0-60 dB	0.3 Watts	0.01 dB	WR-90 Waveguide, UG-39/U Flange
511Ku/419ND	Ku-Band	12.4-18	0.5 dB	0-60 dB	0.3 Watts	0.01 dB	WR-62 Waveguide, UG-419 Flange
511K/595ND	K-Band	18-26.5	0.5 dB	0-60 dB	0.3 Watts	0.01 dB	WR-42 Waveguide, UG-595/U Flange
511(34)/595ND	WR-34	22-33	0.5 dB	0-60 dB	0.3 Watts	0.01 dB	WR-34 Waveguide, UG-595 Flange
511A-599ND	Ka-Band	26.5-40	0.6 dB	0-60 dB	10 Watts	0.01 dB	WR-28 Waveguide, UG-599/U Flange
511B/383ND	Q-Band	33-50	0.7 dB	0-60 dB	7 Watts	0.01 dB	WR-22 Waveguide, UG-383/U Flange
511U/383ND	U-Band	40-60	0.7 dB	0-60 dB	5 Watts	0.01 dB	WR-19 Waveguide, UG-383/U-M Flange
511V/385ND	V-Band	50-75	1.2 dB	0-60 dB	5 Watts	0.01 dB	WR-15 Waveguide, UG-385/U Flange
511E/387ND	E-Band	60-90	1.5 dB	0-60 dB	2 Watts	0.01 dB	WR-12 Waveguide, UG-387/U-M Flange
511W/387ND	W-Band	75-110	1.7 dB	0-60 dB	2 Watts	0.01 dB	WR-10 Waveguide, UG-387/U-M Flange
511F/387ND	F-Band	90-140	2.0 dB	0-60 dB	0.1 Watts	0.01 dB	WR-8 Waveguide, UG-387/U-M Flange
511D/387ND	D-Band	110-170	3.0 dB	0-60 dB	0.1 Watts	0.01 dB	WR-6 Waveguide, UG-387/U-M Flange
511G/387ND	G-Band	140-220	3.8 dB	0-50 dB	0.1 Watts	0.01 dB	WR-5 Waveguide, UG-387/U-M Flange
511H/387ND	H-Band	170-260	6 dB	0-40 dB	0.1 Watts	0.01 dB	WR-4 Waveguide, UG-387/U-M Flange
511J/387ND	J-Band	220-325	7 dB	0-40 dB	0.05 Watts	0.01 dB	WR-03 Waveguide, UG-387/U-M Flange

515 Series

High Accuracy Direct Reading Precision Electronic Attenuators

MI-WAVE®
Millimeter Wave Products Inc.



Description

Mi-Wave's 515 Series Direct-reading electronic Precision Attenuators provide 0 to 60 dB of calibrated attenuation by rotation of a resistive vane mounted in a circular waveguide section. These units are often referred to as precision rotary vane attenuators.

Accuracy .1 dB or $\pm 2\%$ of reading
typical flatness $\pm 5\%$ of reading

- *High Accuracy to 60dB*
- *Low VSWR*
- *Direct Reading*
- *Low Insertion Loss*
- *Anti-backlash Drive*
- *Negligible Phase Shift*
- *Precision Construction*
- *Absolute Attenuation Reading*

Applications

The 515 Series Direct-reading Precision attenuators are used in all RF measurement systems. They are most frequently used in RF substitution-type set-ups for precise measurement of characteristics such as Isolation, Coupling, Insertion Loss and Gain.

Model Number	Band	Frequency (GHz)	Insertion Loss (Typ)	Attenuation Range	Power Handling (CW)	RF Ports
515Ku/419	Ku-Band	12.4-18	0.5 dB	0-60 dB	0.3 Watts	WR-62 Waveguide, UG-419 Flange
515K/595	K-Band	18-26.5	0.5 dB	0-60 dB	0.3 Watts	WR-42 Waveguide, UG-595/U Flange
515(34)/595	WR-34	22-33	0.5 dB	0-60 dB	0.3 Watts	WR-34 Waveguide, UG-595 Flange
515A/599	Ka-Band	26.5-40	0.6 dB	0-60 dB	10 Watts	WR-28 Waveguide, UG-599/U Flange
515B/383	Q-Band	33-50	0.7 dB	0-60 dB	7 Watts	WR-22 Waveguide, UG-383/U Flange
515U/383	U-Band	40-60	0.7 dB	0-60 dB	5 Watts	WR-19 Waveguide, UG-383/U-M Flange
515V/385	V-Band	50-75	1.2 dB	0-60 dB	5 Watts	WR-15 Waveguide, UG-385/U Flange
515E/387	E-Band	60-90	1.5 dB	0-60 dB	2 Watts	WR-12 Waveguide, UG-387/U-M Flange
515W/387	W-Band	75-110	1.8 dB	0-60 dB	2 Watts	WR-10 Waveguide, UG-387/U-M Flange
515F/387	F-Band	90-140	3.0 dB	0-60 dB	0.1 Watts	WR-8 Waveguide, UG-387/U-M Flange
515D/387	D-Band	110-170	3.5 dB	0-50 dB	0.1 Watts	WR-6 Waveguide, UG-387/U-M Flange
515G/387	G-Band	140-220	3.8 dB	0-50 dB	0.1 Watts	WR-5 Waveguide, UG-387/U-M Flange

520/522 Series

Uncalibrated/Calibrated Variable Attenuators

MI-WAVE®
Millimeter Wave Products Inc.

Description

Mi-Wave's 520 Series Uncalibrated Variable Attenuators and 522 Calibrated Attenuators are available in standard waveguide sizes from 12.4 to 325 GHz. The attenuating element in each unit provides a variable attenuation, from 0 dB to 25 dB minimum. Precision-designed internal controls are accurately contoured to provide a low bilateral VSWR and minimum variation of attenuation with frequency.

- *Dial Driven*
- *Compact, Mechanically Stable Design*
- *Wide Range of Attenuation Values*
- *Smooth, Spring-loaded Setting Control*



Applications

The 520/522 Series Variable Attenuators are useful in applications that require a reliable level setting or isolating pad. They provide maximum accuracy in establishing initial power levels in substitution-method attenuation measurements.

Designed to maintain reliable performance for accurate test measurements, the stable setting control of these devices maintains constant attenuation under all normal conditions of vibration and orientation.

Model Number	Band	Frequency (GHz)	Insertion Loss (Typ)	Attenuation Range	Power Handling (CW)	RF Ports
520K/595	K-Band	18-26.5	0.3 dB	0-30 dB	1 Watts	WR-42 Waveguide, UG-595/U Flange
520(34)/595	WR-34	22-33	0.3 dB	0-25 dB	1 Watts	WR-34 Waveguide, UG-595 Flange
520A/599	Ka-Band	26.5-40	0.3 dB	0-25 dB	1 Watts	WR-28 Waveguide, UG-599/U Flange
520B/383	Q-Band	33-50	0.3 dB	0-25 dB	1 Watts	WR-22 Waveguide, UG-383/U Flange
520U/383	U-Band	40-60	0.3 dB	0-25 dB	1 Watts	WR-19 Waveguide, UG-383/U-M Flange
520V/385	V-Band	50-75	0.4 dB	0-25 dB	0.5 Watts	WR-15 Waveguide, UG-385/U Flange
520E/387	E-Band	60-90	0.4 dB	0-25 dB	0.2 Watts	WR-12 Waveguide, UG-387/U-M Flange
520W/387	W-Band	75-110	0.4 dB	0-25 dB	0.1 Watts	WR-10 Waveguide, UG-387/U-M Flange
520F/387	F-Band	90-140	0.5 dB	0-25 dB	0.1 Watts	WR-8 Waveguide, UG-387/U-M Flange
520D/387	D-Band	110-170	0.7 dB	0-20 dB	0.1 Watts	WR-6 Waveguide, UG-387/U-M Flange
520G/387	G-Band	140-220	1.0 dB	0-25 dB	0.1 Watts	WR-5 Waveguide, UG-387/U-M Flange
520H/387	H-Band	170-260	1.5 dB	0-25 dB	0.1 Watts	WR-4 Waveguide, UG-387/U-M Flange
520J/387	J-Band	220-325	1.7 dB	0-25 dB	0.1 Watts	WR-3 Waveguide, UG-387/U-M Flange

Model Number	Band	Frequency (GHz)	Insertion Loss (Typ)	Attenuation Range	Power Handling (CW)	RF Ports
520K/595	K-Band	18-26.5	0.3 dB	0-30 dB	1 Watts	WR-42 Waveguide, UG-595/U Flange
520(34)/595	WR-34	22-33	0.3 dB	0-25 dB	1 Watts	WR-34 Waveguide, UG-595 Flange
520A/599	Ka-Band	26.5-40	0.3 dB	0-25 dB	1 Watts	WR-28 Waveguide, UG-599/U Flange
520B/383	Q-Band	33-50	0.3 dB	0-25 dB	1 Watts	WR-22 Waveguide, UG-383/U Flange
520U/383	U-Band	40-60	0.3 dB	0-25 dB	1 Watts	WR-19 Waveguide, UG-383/U-M Flange
520V/385	V-Band	50-75	0.4 dB	0-25 dB	0.5 Watts	WR-15 Waveguide, UG-385/U Flange
520E/387	E-Band	60-90	0.4 dB	0-25 dB	0.2 Watts	WR-12 Waveguide, UG-387/U-M Flange
520W/387	W-Band	75-110	0.4 dB	0-25 dB	0.1 Watts	WR-10 Waveguide, UG-387/U-M Flange
520F/387	F-Band	90-140	0.5 dB	0-25 dB	0.1 Watts	WR-8 Waveguide, UG-387/U-M Flange
520D/387	D-Band	110-170	0.7 dB	0-20 dB	0.1 Watts	WR-6 Waveguide, UG-387/U-M Flange
520G/387	G-Band	140-220	1.0 dB	0-25 dB	0.1 Watts	WR-5 Waveguide, UG-387/U-M Flange
520H/387	H-Band	170-260	1.5 dB	0-25 dB	0.1 Watts	WR-4 Waveguide, UG-387/U-M Flange
520J/387	J-Band	220-325	1.7 dB	0-25 dB	0.1 Watts	WR-3 Waveguide, UG-387/U-M Flange

523 Series

Micrometer Type Variable Waveguide Attenuators

MI-WAVE®
Millimeter Wave Products Inc.

Description

Mi-Wave's 523 Series Micrometer-driven Calibrated Attenuators are compact precision attenuating devices available in standard waveguide sizes from 18.0 to 220 GHz.

Each attenuator is calibrated at the frequency specified at the time of order.

The 523 Series Micrometer-driven Calibrated Attenuators are designed for laboratory applications in standard waveguide bands from 18.0 to 220.0 GHz. The drive mechanism is designed for the high resolution of vane insertion vs. attenuation characteristics that is required for the small waveguide dimensions associated with the higher millimeter wave frequencies. These attenuators are very useful for insertion loss measurements, and a wide variety of other attenuation and power level determinations

- *High Resolution*
- *Micrometer Readout*
- *Differential Screw Drive*
- *Anti-backlash Operation*
- *Excellent Mechanical Stability*
- *Calibration Curve Provided at Specified Frequency*



Applications

- Instrumentation
- Manual Test Setups

Model Number	Band	Frequency (GHz)	Insertion Loss (Typ)	Attenuation Range	Power Handling (CW)	RF Ports
520K/595	K-Band	18-26.5	0.3 dB	0-30 dB	0.3 Watts	WR-42 Waveguide, UG-595/U Flange
520A/599	Ka-Band	26.5-40	0.3 dB	0-25 dB	0.3 Watts	WR-28 Waveguide, UG-599/U Flange
520B/383	Q-Band	33-50	0.4 dB	0-25 dB	0.3 Watts	WR-22 Waveguide, UG-383/U Flange
520U/383	U-Band	40-60	0.3 dB	0-25 dB	0.2 Watts	WR-19 Waveguide, UG-383/U-M Flange
520V/385	V-Band	50-75	0.4 dB	0-25 dB	0.2 Watts	WR-15 Waveguide, UG-385/U Flange
520E/387	E-Band	60-90	0.3 dB	0-25 dB	0.2 Watts	WR-12 Waveguide, UG-387/U-M Flange
520W/387	W-Band	75-110	0.4 dB	0-25 dB	0.1 Watts	WR-10 Waveguide, UG-387/U-M Flange
520F/387	F-Band	90-140	0.5 dB	0-25 dB	0.1 Watts	WR-8 Waveguide, UG-387/U-M Flange
520D/387	D-Band	110-170	0.5 dB	0-20 dB	0.1 Watts	WR-6 Waveguide, UG-387/U-M Flange
520G/387	G-Band	140-220	0.8 dB	0-25 dB	0.1 Watts	WR-5 Waveguide, UG-387/U-M Flange

521/524 Series

Fixed Attenuators

MI-WAVE®

Millimeter Wave Products Inc.

Description

Mi-Wave's 521/524 Series Fixed Attenuators are available in attenuation values up to 30 dB for each Band from 18 to 325 GHz. Each fixed attenuator is calibrated at the exact frequency specified and is accurate within 0.1 dB or 1%.

- *Wide Range of Accurately Calibrated Values*
- *Available in Every Waveguide Size from 18 to 325 GHz*

Applications

The 521/524 Series Fixed Attenuators are used in millimeter wave applications that require accurate fixed attenuation levels in waveguide transmission lines. All units are H-plane fixed attenuators. The attenuators are useful for isolating generators from mismatched load effects.

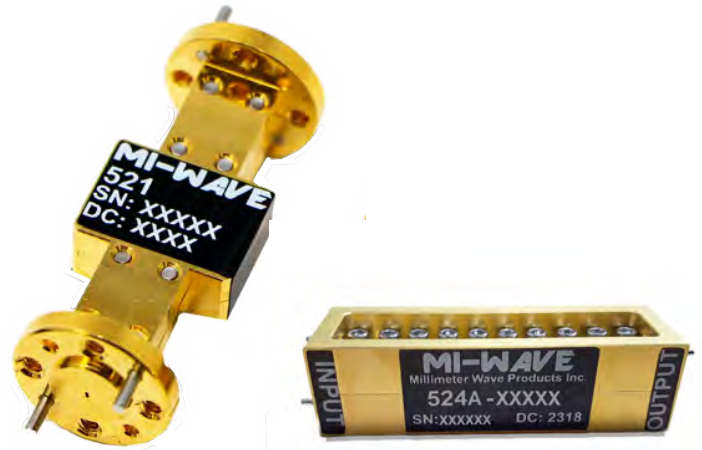

Model	Band Type	Frequency (GHz)	Attenuation (X)	Power Handling (CW)	RF Ports
521K-X/595	K-Band	18-26.5	3, 6, 10, 20, 30 dB	1 Watts	WR-42 Waveguide UG-595/U Flange
521A-X/599	Ka-Band	26.5-40	3, 5, 10, 20, 30 dB	1 Watts	WR-42 Waveguide UG-599/U Flange
521B-X/383	Q-Band	33-50	3, 5, 10, 20, 30 dB	1 Watts	WR-22 Waveguide UG-383/U Flange
521U-X/383	U-Band	40-60	3, 6, 10, 20, 30 dB	1 Watts	WR-19 Waveguide UG-383/U-M Flange
521V-X/385	V-Band	50-75	3, 6, 10, 20, 30 dB	0.5 Watts	WR-15 Waveguide UG-385/U Flange
521E-X/387	E-Band	60-90	3, 6, 10, 20, 30 dB	0.2 Watts	WR-12 Waveguide UG-387/U Flange
521W-X/387	W-Band	75-110	3, 6, 10, 20, 30 dB	0.1 Watts	WR-10 Waveguide UG-387/U-M Flange
521F-X/387	F-Band	90-140	3, 6, 10, 20, 30 dB	0.1 Watts	WR-8 Waveguide UG-387/U-M Flange
521D-X/387	D-Band	110-170	3, 6, 10, 20, 30 dB	0.1 Watts	WR-6 Waveguide UG-387/U-M Flange
521G-X/387	G-Band	140-220	3, 6, 10, 20, 30 dB	0.1 Watts	WR-5 WaveguideUG-387/U-M Flange
521H-X/387	H-Band	170-260	3, 5, 6, 10, 20, 30 dB	0.1 Watts	WR-4 Waveguide UG-387/U Flange
521J-X/387	J-Band	220-325	3, 5, 6, 10, 20, 30 dB	0.1 Watts	WR-3 Waveguide UG-387/U Flange

Model	Band Type	Frequency (GHz)	Attenuation (X)	Power Handling (CW)	RF Ports
524K-X/595	K-Band	18-26.5	3, 6, 10, 20, 30, 40, 50 dB	150 Watts	WR-42 Waveguide UG-595/U Flange
524A-X/599	Ka-Band	26.5-40	3, 6, 10, 20, 30, 40, 50 dB	75 Watts	WR-42 Waveguide UG-599/U Flange
524B-X/383	Q-Band	33-50	3, 6, 10, 20, 30, 40, 50 dB	20 Watts	WR-22 Waveguide UG-383/U Flange
524U-X/383	U-Band	40-60	3, 6, 10, 20, 30, 40, 50 dB	10 Watts	WR-19 Waveguide UG-383/U-M Flange
524V-X/385	V-Band	50-75	3, 6, 10, 20, 30, 40, 50 dB	10 Watts	WR-15 Waveguide UG-385/U Flange
524E-X/387	E-Band	60-90	3, 6, 10, 20, 30, 40, 50 dB	10 Watts	WR-12 Waveguide UG-387/U Flange
524W-X/387	W-Band	75-110	3, 6, 10, 20, 30, 40, 50 dB	10 Watts	WR-10 Waveguide UG-387/U-M Flange
524F-X/387	F-Band	90-140	3, 6, 10, 20, 30 dB	1 Watts	WR-8 Waveguide UG-387/U-M Flange
524D-X/387	D-Band	110-170	3, 6, 10, 20, 30 dB	1 Watts	WR-6 Waveguide UG-387/U-M Flange
524G-X/387	G-Band	140-220	3, 6, 10, 20, 30 dB	1 Watts	WR-5 WaveguideUG-387/U-M Flange
524H-X/387	H-Band	170-260	3, 6, 10, 20, 30 dB	0.5 Watts	WR-4 Waveguide UG-387/U Flange

525/526 Series

Uncalibrated/Calibrated Phase Shifters

MI-WAVE®
Millimeter Wave Products Inc.



Description

Mi-Wave's 525 Uncalibrated and 526 Calibrated Phase Shifters provide phase shifts from 0° to 180° at any frequency within the Band.

Designed to maintain reliable performance for accurate test measurements, the firm setting control of these devices maintains stable performance under all normal conditions of unit orientation and test bench vibration.

- *Dial Driven*
- *Smooth Phase Shift Control*
- *Compact and Mechanically-stable Design*
- *Settings Maintained in all Orientations*

Applications

Mi-Wave's 525 Series Uncalibrated Phase Shifters are designed for applications that require variation in the electrical length of a transmission line section with minimum energy loss and reflections. These devices are used in test bench bridge circuits and balanced mixers to provide control of the phase relationship between RF signals. They may also be used to control similar phase relations in array-type antenna systems.

Model Number	Band	Frequency (GHz)	Insertion Loss (Typ)	Phase Shift Range	Power Handling (CW)	RF Ports
525K/595	K-Band	18-26.5	0.3 dB	0°-180°	1.5W	WR-42 Waveguide, UG-595/U Flange
525A/599	Ka-Band	26.5-40	0.3 dB	0°-180°	1W	WR-28 Waveguide, UG-599/U Flange
525B/383	Q-Band	33-50	0.3 dB	0°-180°	1W	WR-22 Waveguide, UG-383/U Flange
525U/383	U-Band	40-60	0.3 dB	0°-180°	1W	WR-19 Waveguide, UG-383/U-M Flange
525V/385	V-Band	50-75	0.4 dB	0°-180°	0.8W	WR-15 Waveguide, UG-385/U Flange
525E/387	E-Band	60-90	0.5 dB	0°-180°	0.7W	WR-12 Waveguide, UG-387/U-M Flange
525W/387	W-Band	75-110	0.5 dB	0°-180°	0.6W	WR-10 Waveguide, UG-387/U-M Flange
525F/387	F-Band	90-140	0.6 dB	0°-180°	0.3W	WR-8 Waveguide, UG-387/U-M Flange
525D/387	D-Band	110-170	0.8 dB	0°-180°	0.3W	WR-6 Waveguide UG-387/U-M Flange
525G/387	G-Band	140-220	0.8 dB	0°-180°	0.3W	WR-5 WaveguideUG-387/U-M Flange

Model Number	Band	Frequency (GHz)	Insertion Loss (Typ)	Phase Shift Range	Power Handling (CW)	RF Ports
526K/595	K-Band	18-26.5	0.3 dB	0°-180°	1.5W	WR-42 Waveguide, UG-595/U Flange
526A/599	Ka-Band	26.5-40	0.3 dB	0°-180°	1W	WR-28 Waveguide, UG-599/U Flange
526B/383	Q-Band	33-50	0.3 dB	0°-180°	1W	WR-22 Waveguide, UG-383/U Flange
526U/383	U-Band	40-60	0.3 dB	0°-180°	1W	WR-19 Waveguide, UG-383/U-M Flange
526V/385	V-Band	50-75	0.4 dB	0°-180°	0.8W	WR-15 Waveguide, UG-385/U Flange
526E/387	E-Band	60-90	0.5 dB	0°-180°	0.7W	WR-12 Waveguide, UG-387/U-M Flange
526W/387	W-Band	75-110	0.5 dB	0°-180°	0.6W	WR-10 Waveguide, UG-387/U-M Flange
526F/387	F-Band	90-140	0.6 dB	0°-180°	0.3W	WR-8 Waveguide, UG-387/U-M Flange
526D/387	D-Band	110-170	0.8 dB	0°-180°	0.3W	WR-6 Waveguide, UG-387/U-M Flange
526G/387	G-Band	140-220	0.8 dB	0°-180°	0.3W	WR-5 WaveguideUG-387/U-M Flange

527/528 Series

Micrometer-driven Calibrated Phase Shifters and Direct-reading Phase Shifters

MI-WAVE®

Millimeter Wave Products Inc.



Description

Mi-Wave's 527 Series Phase Shifters are designed for operation in waveguide sizes from 18 to 220 GHz. This resolution is advantageous since the total travel of the phase shift vane is quite short at high frequencies.

- *Low VSWR*
- *Micrometer Readout*
- *Smooth Anti-Backlash Operation*

The precise micrometer readout enhances setting and repeatability of these devices tested. Each phase shifter is at the specified frequency. Calibrations are supplied at an additional cost.

Model Number	Band	Frequency	Insertion Loss (Typ)	Power Handling (CW)	Phase Shift Range	RF Ports
527K/595	K-Band	18-26.5	0.3 dB	1.5 W	0°-180°	WR-42 Waveguide, UG-595/U Flange
527A/599	Ka-Band	26.5-40	0.3 dB	1 W	0°-180°	WR-28 Waveguide, UG-599/U Flange
527B/383	Q-Band	33-50	0.3 dB	1 W	0°-180°	WR-22 Waveguide, UG-383/U Flange
527U/383	U-Band	40-60	0.1 dB	1 W	0°-180°	WR-19 Waveguide, UG-383/U-M Flange
527V/385	V-Band	50-75	0.4 dB	0.8W	0°-180°	WR-15 Waveguide, UG-385/U Flange
527E/387	E-Band	60-90	0.5 dB	0.7 W	0°-180°	WR-12 Waveguide, UG-387/U-M Flange
527W/387	W-Band	75-110	0.5 dB	0.6 W	0°-180°	WR-10 Waveguide, UG-387/U-M Flange
527F/387	F-Band	90-140	0.6 dB	0.4 W	0°-180°	WR-8 Waveguide, UG-387/U-M Flange
527D/387	D-Band	110-170	0.8 dB	0.3 W	0°-180°	WR-6 Waveguide, UG-387/U-M Flange
527G/387	G-Band	140-220	1.0 dB	0.2 W	0°-180°	WR-5 Waveguide, UG-387/U-M Flange

Description

Mi-Wave's 528 Series Direct-reading Phase Shifters provide highly accurate measurement of phase shift over each full Band from 26.5 to 170 GHz. They feature Low VSWR, low insertion-loss, and low insertion-loss variation due to the rotation of the phasing section.

Applications

The 528 Series Direct-reading Phase shifters offer a convenient, frequency insensitive method of measuring phase shift. These devices are useful in waveguide systems where the phase and amplitude must be measured or adjusted independently. Typical applications include bridge circuits, phased arrays, and interferometers.

- *Compact Mechanically-Stable Design*
- *Smooth Anti-backlash Phase Shift Control*
- *High Resolution Over a Wide Phase-shifting Range*



Model Number	Band	Frequency	Insertion Loss (Typ)	Phase Shift Range	Power Handling (CW)	RF Ports
528A/599	Ka-Band	26.5-40	1 dB	0°-360°	1W	WR-28 Waveguide, UG-599/U Flange
528B/383	Q-Band	33-50	1.2 dB	0°-360°	1W	WR-22 Waveguide, UG-383/U Flange
528U/383	U-Band	40-60	1.3 dB	0°-360°	1W	WR-19 Waveguide, UG-383/U-M Flange
528V/385	V-Band	50-75	1.5 dB	0°-360°	0.8W	WR-15 Waveguide, UG-385/U Flange
528E/387	E-Band	60-90	1.8 dB	0°-360°	0.7W	WR-12 Waveguide, UG-387/U-M Flange
528W/387	W-Band	75-110	2 dB	0°-360°	0.6W	WR-10 Waveguide, UG-387/U-M Flange
528F/387	F-Band	90-140	3 dB	0°-360°	0.3W	WR-8 Waveguide, UG-387/U-M Flange
528D/387	D-Band	110-170	4 dB	0°-360°	0.3W	WR-6 Waveguide, UG-387/U-M Flange

529 Series

Motorized Rotary Vane Phase Shifters

MI-WAVE®
Millimeter Wave Products Inc.



Description

Mi-Wave has developed a new motorized rotary vane phase shifter which is available in W/G bands from 18.0 to 170 GHz. The 529 Series is a computer-controlled version of Mi-Waves' standard direct reading phase shifter and features a 0° to 360° range with 0.5-degree resolution. IEEE-488 and USB available.

- High Accuracy
- Digital Readout
- Low Insertion Loss
- Computer Controlled
- Precision Construction
- Full Bands

The phase shifter is controlled by a precision stepping motor and all electronics required to drive the motor are contained within the phase shifter housing.

Custom microprocessor-based electronics translate the desired phase shifter setting into the required motor position and provide the proper drive signals for the motor. Motor speed is ramped up and down ensuring accurate positioning and smooth operation. The unit can be controlled remotely through an IEEE-488 interface or manually with a front panel switch. A three-digit readout on the front panel displays the setting. All that is required is a 24-volt, 500 mA supply, which is included.

Applications

The 529 Series Motorized Direct-reading Phase Shifters are used in all RF automated measurement systems. They are most frequently used in RF substitution-type set-ups for precise measurement of characteristics including bridge circuits and phased arrays.

Model Number	Band	Frequency (GHz)	Resolution	Accuracy (+)	Power Handling (CW)	Insertion Loss (Typ)	RF Ports
529K/595	K-Band	18-26.5	0.5°	4°	1	1 dB	WR-42 Waveguide, UG-595/U Flange
529A/599	Ka-Band	26.5-40	0.5°	4°	0.5	1 dB	WR-28 Waveguide, UG-599/U Flange
529B/383	Q-Band	33-50	0.5°	4°	0.5	1 dB	WR-22 Waveguide, UG-383/U Flange
529U/383	U-Band	40-60	0.5°	4°	0.4	1.1 dB	WR-19 Waveguide, UG-383/U-M Flange
529V/385	V-Band	50-75	0.5°	4°	0.3	1.2 dB	WR-15 Waveguide, UG-385/U Flange
529E/387	E-Band	60-90	0.5°	4°	0.2	1.4 dB	WR-12 Waveguide, UG-387/U-M Flange
529W/387	W-Band	75-110	0.5°	4°	0.2	1.5 dB	WR-10 Waveguide, UG-387/U-M Flange
529F/387	F-Band	90-140	0.5°	5°	0.2	2 dB	WR-8 Waveguide, UG-387/U-M Flange
529D/387	D-Band	110-170	0.5°	5°	0.1	3 dB	WR-6 Waveguide, UG-387/U-M Flange

530 Series

Manual waveguide Switches

MI-WAVE®
Millimeter Wave Products Inc.

Description

Mi-Wave's 530 Series Manual Switches are designed for use in standard millimeter wave frequency bands from 26.5 to 325 GHz. Each unit will operate over the full Bandwidth with minimum Insertion Loss, minimum VSWR, and maximum Isolation between coupled and uncoupled waveguide sections.

- *Positive Indexing*
- *Optimum Isolation*
- *Non-contacting Choke Coupling*
- *Versatile Switching Combinations*



Applications

The 530 Series Manual Waveguide Switches are used for transmission switching applications in millimeter wave systems. These versatile devices provide a variety of switching combinations using three waveguide channels and three positions. In a typical radar application, a three-position switch can be used manually to switch one of two transmitters to a common antenna, while simultaneously connecting the other transmitter to a suitable termination. A manual switch will also provide a convenient means for alternately connecting a test antenna and standard horn to Gain-measuring test equipment.

Model Number	Band	Frequency (GHz)	Insertion Loss (Typ)	VSWR (Typ)	Isolation (Typ)	Power Handling (CW)	Plane Type	RF Ports
530X/39	X-Band	8.2-12.4	0.3 dB	1.15:1	60 dB	100W	E-Plane	WR-90 Waveguide, UG-39/U Flange
530Ku/419	Ku-Band	12.4-18	0.3 dB	1.15:1	60 dB	100W	E-Plane	WR-62 Waveguide, UG-419 Flange
530K/595	K-Band	18-26.5	0.3 dB	1.15:1	60 dB	100W	E-Plane	WR-42 Waveguide, UG-595/U Flange
530A/599	Ka-Band	26.5-40	0.3 dB	1.15:1	60 dB	100W	E-Plane or H-Plane	WR-28 Waveguide, UG-599/U Flange
530B/383	Q-Band	33-50	0.3 dB	1.15:1	60 dB	100W	E-Plane or H-Plane	WR-22 Waveguide, UG-383/U Flange
530U/382	U-Band	40-60	0.3 dB	1.15:1	60 dB	100W	H-Plane	WR-19 Waveguide, UG-383/U-M Flange
530V/385	V-Band	50-75	0.4 dB	1.15:1	60 dB	100W	H-Plane	WR-15 Waveguide, UG-385/U Flange
530E/387	E-Band	60-90	0.5 dB	1.15:1	60 dB	100W	H-Plane	WR-12 Waveguide, UG-387/U-M Flange
530W/387	W-Band	75-110	0.4 dB	1.15:1	60 dB	100W	H-Plane	WR-10 Waveguide, UG-387/U-M Flange
530F/387	F-Band	90-140	0.7 dB	1.15:1	50 dB	100W	H-Plane	WR-8 Waveguide, UG-387/U-M Flange
530D/387	D-Band	110-170	0.7 dB	1.15:1	50 dB	100W	H-Plane	WR-6 Waveguide, UG-387/U-M Flange
530G/387	G-Band	140-220	1 dB	1.25:1	45 dB	100W	H-Plane	WR-5 Waveguide, UG-387/U-M Flange
530H/387	H-Band	170-260	1 dB	1.25:1	45 dB	100W	H-Plane	WR-4 Waveguide, UG-387/U-M Flange
530J/387	J-Band	220-325	2 dB	1.30:1	40 dB	100W	H-Plane	WR-03 Waveguide, UG-387/U-M Flange

535 Series

Two-position Solenoid Switches

MI-WAVE®
Millimeter Wave Products Inc.



Description

Each of Mi-Wave's 535 Series Waveguide Switches consists of a waveguide switch selection similar to the 530 Series switch and a rotary motor encased in a machined housing.

Applications

The 535 Series Solenoid Switches are used in applications that require remote-controlled or timed transmission line switching. They are particularly useful in operational systems and test setups where they supply a variety of switching combinations.

- *Low Loss*
- *Low VSWR*
- *Accurate Positioning*
- *High Isolation Between Ports*
- *GPIB IEEE-488 Control Available*
- *TTL Control Standard*

Model Number	Band	Frequency (GHz)	Insertion Loss (Typ)	Isolation (Typ)	Power Handling (CW)	Bias Voltage (V)	Bias Current (mA)	Switching Speed (sec)	RF Ports
535X/39TTL	X-Band	8.2-12.4	0.3 dB	60 dB	100W	12 to 15	150	0.5	WR-90 Waveguide, UG-39/U Flange
535Ku/419TTL	Ku-Band	12.4-18	0.3 dB	60 dB	100W	12 to 15	150	0.5	WR-62 Waveguide, UG-419 Flange
535K/595TTL	K-Band	18-26.5	0.3 dB	60 dB	100W	12 to 15	150	0.5	WR-42 Waveguide, UG-595/U Flange
535A/599TTL	Ka-Band	26.5-40	0.3 dB	60 dB	100W	12 to 15	150	0.5	WR-28 Waveguide UG-599/U Flange
535B/383TTL	Q-Band	33-50	0.3 dB	60 dB	100W	12 to 15	150	0.5	WR-22 Waveguide UG-383/U Flange
535U/383TTL	U-Band	40-60	0.3 dB	60 dB	100W	12 to 15	150	0.5	WR-19 Waveguide UG-383/U-M Flange
535V/385/TTL	V-Band	50-75	0.4 dB	60 dB	100W	12 to 15	150	0.5	WR-15-Waveguide UG-385/U Flange
535E/387TTL	E-Band	60-90	0.4 dB	60 dB	100W	12 to 15	150	0.5	WR-12 Waveguide UG-387/U Flange
535W/387TTL	W-Band	75-110	0.5 dB	60 dB	100W	12 to 15	150	0.5	WR-10 Waveguide UG-387/U-M Flange
535F/387TTL	F-Band	90-140	0.8 dB	60 dB	100W	12 to 15	150	0.5	WR-8 Waveguide UG-387/U-M Flange
535D/387TTL	D-Band	110-170	1 dB	50 dB	100W	12 to 15	150	0.5	WR-6 Waveguide UG-387/U-M Flange
535G/387TTL	G-Band	140-220	1.3 dB	50 dB	100W	12 to 15	150	0.5	WR-5 Waveguide UG-387/U-M Flange

551 Series

Direct-reading Frequency Meters

MI-WAVE®
Millimeter Wave Products Inc.



Description

Each of Mi-Wave's 551 Series Direct-reading Frequency Meters are available in standard waveguide sizes from 26.5 to 110.0 GHz and are designed to provide easy direct readout of frequency with a high degree of resolution and accuracy.

- *Full Band*
- *Direct Reading*
- *High Resolution*
- *Anti-backlash Drive*

Applications

The 551 Series Direct-reading Frequency Meters provide a quick and accurate method of determining frequency over the complete Band to facilitate measurements in any research, development, or production applications.

Model Number	Band	Frequency (GHz)	Resonance Dip (Typ)	Insertion Loss (Typ)	RF Ports
551A/595	Ka-Band	26.5-40	3 dB	0.8 dB	WR-28 Waveguide, UG-599/U Flange
551B/383	Q-Band	33-50	3 dB	0.8 dB	WR-22 Waveguide, UG-383/U Flange
551U/383	U-Band	40-60	3 dB	0.8 dB	WR-19 Waveguide, UG-383/U-M Flange
551V/383	V-Band	50-75	3 dB	0.8 dB	WR-15 Waveguide, UG-385/U Flange
551E/387	E-Band	60-90	3 dB	0.8 dB	WR-12 Waveguide, UG-387/U-M Flange
551W/387	W-Band	75-110	3 dB	0.8 dB	WR-10 Waveguide, UG-387/U-M Flange

555/556 Series

Bi-directional Waveguide and Blocktype Couplers

MI-WAVE®
Millimeter Wave Products Inc.

Description

Mi-Wave's 555 Series Bi-directional couplers are Broadband, broadwall waveguide type. The 556 are split block type components with a multi-hold Directivity. The 555 Series couplers are available in 3, 6, 10, 20, 30, and 40 dB Coupling values for standard Bands from 26.5 to 110 GHz.

- High Directivity
- Accurate Coupling
- Full Bandwidth

Applications

The 555 Series Bi-directional Couplers are used in applications that require precise sampling of both incident and reflected energy. The 3 dB couplers are especially useful in balanced mixer work where Broadband power division of RF and LO signals is required to supply both sides of a balanced mixer unit. The 3 dB bi-directional couplers can provide full bandwidth power division.

556 Series Block Type Couplers are available from 26.5 to 110 GHz



Model Number	Band	Frequency (GHz)	Coupling Value (dB)	Directivity (Typ)	Coupling Flatness	Coupling Accuracy	VSWR (Typ)	RF Ports
555A-X/599	Ka-Band	26.5-40	3, 6, 10, 20, 30, 40	30 dB	±0.7 dB	± 1 dB	1.05:1	WR-28 Waveguide, UG-599 Flange
555B-X/383	Q-Band	33-50	3, 6, 10, 20, 30, 40	35 dB	± 1 dB	± 1.5 dB	1.10:1	WR-22 Waveguide, UG-383 Flange
555U-X/383	U-Band	40-60	3, 6, 10, 20, 30, 40	35 dB	±0.7 dB	± 1 dB	1.05:1	WR-19 Waveguide, UG-383 Flange
555V-X/385	V-Band	50-75	3, 6, 10, 20, 30, 40	30 dB	±0.7 dB	± 1 dB	1.10:1	WR-15 Waveguide, UG-385 Flange
555E-X/387	E-Band	60-90	3, 6, 10, 20, 30, 40	30 dB	± 1 dB	± 1.5 dB	1.10:1	WR-12 Waveguide, UG-387 Flange
555W-X/387	W-Band	75-110	3, 6, 10, 20, 30, 40	30 dB	± 1 dB	± 1.5 dB	1.10:1	WR-10 Waveguide, UG-387 Flange

Model Number	Band	Frequency (GHz)	Coupling Value (dB)	Directivity (Typ)	Coupling Flatness	Coupling Accuracy	VSWR (Typ)	RF Ports
556A-X/599	Ka-Band	26.5-40	3, 6, 10, 20, 30, 40	30 dB	±0.7 dB	± 1 dB	1.05:1	WR-28 Waveguide, UG-599 Flange
556A-X/599	Ka-Band	26.5-40	3, 6, 10, 20, 30, 40	30 dB	±0.7 dB	± 1 dB	1.05:1	WR-28 Waveguide, UG-599 Flange
556B-X/383	Q-Band	33-50	3, 6, 10, 20, 30, 40	35 dB	± 1 dB	± 1.5 dB	1.10:1	WR-22 Waveguide, UG-383 Flange
556U-X/383	U-Band	40-60	3, 6, 10, 20, 30, 40	35 dB	±0.7 dB	± 1 dB	1.05:1	WR-19 Waveguide, UG-383 Flange
556V-X/385	V-Band	50-75	3, 6, 10, 20, 30, 40	30 dB	±0.7 dB	± 1 dB	1.10:1	WR-15 Waveguide, UG-385 Flange
556E-X/387	E-Band	60-90	3, 6, 10, 20, 30, 40	30 dB	± 1 dB	± 1.5 dB	1.10:1	WR-12 Waveguide, UG-387 Flange
556W-X/387	W-Band	75-110	3, 6, 10, 20, 30, 40	30 dB	± 1 dB	± 1.5 dB	1.10:1	WR-10 Waveguide, UG-387 Flange
556W-X/387	W-Band	75-110	3, 6, 10, 20, 30, 40	30 dB	± 1 dB	± 1.5 dB	1.10:1	WR-10 Waveguide, UG-387 Flange
556W-X/387	W-Band	75-110	3, 6, 10, 20, 30, 40	30 dB	± 1 dB	± 1.5 dB	1.10:1	WR-10 Waveguide, UG-387 Flange
556W-X/387	W-Band	75-110	3, 6, 10, 20, 30, 40	30 dB	± 1 dB	± 1.5 dB	1.10:1	WR-10 Waveguide, UG-387 Flange
556W-X/387	W-Band	75-110	3, 6, 10, 20, 30, 40	30 dB	± 1 dB	± 1.5 dB	1.10:1	WR-10 Waveguide, UG-387 Flange
556W-X/387	W-Band	75-110	3, 6, 10, 20, 30, 40	30 dB	± 1 dB	± 1.5 dB	1.10:1	WR-10 Waveguide, UG-387 Flange

559/560 Series

Broadband Directional Couplers H and E

MI-WAVE®

Millimeter Wave Products Inc.

559 H-Plane



Description

Each of Mi-Wave's 559 Series Broadband Directional Couplers are broadwall multi-hole energy-coupling devices. The 559 Series couplers are designed in 7 Couplings of 3, 6, 10, 20, 30, 40 and 50 dB are offered to complement specific test set requirements. Other custom configurations are available upon request.

- *Broadband*
- *Low VSWR*
- *High Directivity (Typ)*
- *Rugged Construction*
- *High Coupling Accuracy*
- *Calibrated Coupling values*
- *Minimum Coupling Variation with Frequency*

Applications

The 559 Series Directional Couplers provide an efficient and convenient means for sampling a finite quantity of power flowing in a transmission line or for injecting a desired signal into the line.

Model Number	Frequency (GHz)	Coupling Value (X)	Directivity (Typ)	Insertion Loss (Typ)	VSWR (Typ)	RF Ports
559K-X/595	18-26.5	3, 6, 10, 20, 30, 40, 50 dB	40 dB	1 dB	1.05:1	WR-42 Waveguide, UG-595 Flange
559A-X/599	26.5-40	3, 6, 10, 20, 30, 40, 50 dB	40 dB	1 dB	1.05:1	WR-28 Waveguide, UG-599 Flange
559B-X/383	33-50	3, 6, 10, 20, 30, 40, 50 dB	40 dB	1 dB	1.10:1	WR-22 Waveguide, UG-383 Flange
559U-X/383	40-60	3, 6, 10, 20, 30, 40, 50 dB	40 dB	1 dB	1.05:1	WR-19 Waveguide, UG-383 Flange
559V-X/385	50-75	3, 6, 10, 20, 30, 40, 50 dB	40 dB	1 dB	1.10:1	WR-15 Waveguide, UG-385 Flange
559E-X/387	60-90	3, 6, 10, 20, 30, 40, 50 dB	40 dB	1 dB	1.10:1	WR-12 Waveguide, UG-387 Flange
559W-X/387	75-110	3, 6, 10, 20, 30, 40, 50 dB	40 dB	1 dB	1.10:1	WR-10 Waveguide, UG-387 Flange

Description

Mi-Wave's 560 Series Broadband Directional Couplers are broadwall E-plane multi-hole energy-coupling devices. The 560 Series couplers are designed in 8 waveguide sizes from 18 to 110 GHz. Nominal Couplings of 3, 6, 10, 20, 30, 40 and 50 dB are offered to complement specific test set requirements.

- *Broadband*
- *Low VSWR*
- *E-plane Design*
- *High Directivity*
- *Rugged Construction*
- *High Coupling Accuracy*
- *Calibrated Coupling values*
- *Minimum Coupling Variation with Frequency*

Applications

The 560 Series directional couplers provide an efficient and convenient means for sampling a finite quantity of power flowing in a transmission line or for injecting a desired signal into the line.

560 E-Plane



Model Number	Frequency (GHz)	Coupling value (X)	Directivity (Typ)	Insertion Loss (Typ)	VSWR (Typ)	RF Ports
560K-X/595	18-26.5	3, 6, 10, 20, 30, 40, 50 dB	40 dB	1 dB	1.05:1	WR-42 Waveguide, UG-595 Flange
560A-X/599	26.5-40	3, 6, 10, 20, 30, 40, 50 dB	40 dB	1 dB	1.05:1	WR-28 Waveguide, UG-599 Flange
560B-X/383	33-50	3, 6, 10, 20, 30, 40, 50 dB	40 dB	1 dB	1.10:1	WR-22 Waveguide, UG-383 Flange
560U-X/383	40-60	3, 6, 10, 20, 30, 40, 50 dB	40 dB	1 dB	1.05:1	WR-19 Waveguide, UG-383 Flange
560V-X/385	50-75	3, 6, 10, 20, 30, 40, 50 dB	40 dB	1 dB	1.10:1	WR-15 Waveguide, UG-385 Flange
560E-X/387	60-90	3, 6, 10, 20, 30, 40, 50 dB	40 dB	1 dB	1.10:1	WR-12 Waveguide, UG-387 Flange

561 Series

Broadband Directional Couplers

MI-WAVE®
Millimeter Wave Products Inc.

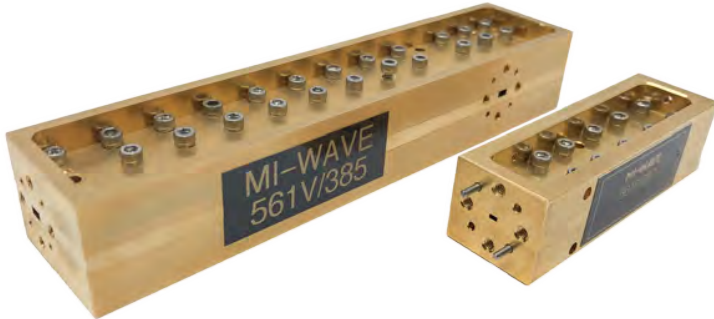

Description

Mi-Wave's 561 Series Broadband Directional Couplers are broadwall multihole energy-coupling devices. The 561 Series devices are available in various waveguide sizes ranging in frequency from 26.5 to 500 GHz.

Nominal Couplings of 3, 6, 10, 20, 30, 40 and 50 dB are offered to complement specific test set requirements.

- *Broadband*
- *Low VSWR*
- *High Directivity*
- *Rugged Construction*
- *High Coupling Accuracy*
- *Calibrated Coupling values*
- *Minimum Coupling Variation with Frequency*

Applications

The 561 Series Directional Couplers provide an efficient and convenient means for sampling a finite quantity of power flowing in a transmission line or for injecting a desired signal into the line.

Model Number	Frequency (GHz)	Coupling Value (X)	Directivity (Typ)	Insertion Loss (Typ)	Main Line VSWR (Typ)	Auxiliary Line VSWR (Typ)	RF Ports
561A-X/599	26.5-40	3, 6, 10, 20, 30, 40, 50 dB	35 dB	0.4 dB	1.05:1	1.12:1	WR-28 Waveguide, UG-595/U Square Flange
561B-X/383	33-50	3, 6, 10, 20, 30, 40, 50 dB	35 dB	0.5 dB	1.05:1	1.12:1	WR-22 Waveguide, UG-383/U Round Flange
561U-X/383	40-60	3, 6, 10, 20, 30, 40, 50 dB	35 dB	0.6 dB	1.05:1	1.12:1	WR-19 Waveguide, UG-383/U-M Round Flange
561V-X/387	50-75	3, 6, 10, 20, 30, 40, 50 dB	35 dB	1 dB	1.10:1	1.15:1	WR-12 Waveguide, UG-387/U Round Flange
561E-X/387	60-90	3, 6, 10, 20, 30, 40, 50 dB	35 dB	1 dB	1.10:1	1.15:1	WR-12 Waveguide, UG-387/U Round Flange
561W-X/387	75-110	3, 6, 10, 20, 30, 40, 50 dB	35 dB	1 dB	1.10:1	1.15:1	WR-10 Waveguide, UG-387/U-M Round Flange
561F-X/387	90-140	3, 6, 10, 20, 30, 40, 50 dB	25 dB	1.5 dB	1.10:1	1.17:1	WR-08 Waveguide, UG-387/U-M Round Flange
561D-X/387	110-170	3, 6, 10, 20, 30, 40, 50 dB	25 dB	1.5 dB	1.10:1	1.17:1	WR-07 Waveguide, UG-387/U-M Round Flange
561G-X/387	140-220	3, 6, 10, 20, 30, 40, 50 dB	25 dB	1.5 dB	1.15:1	1.20:1	WR-06 Waveguide, UG-387/U-M Round Flange
561H-X/387	170-260	3, 6, 10, 20, 30, 40, 50 dB	25 dB	3.5 dB	1.15:1	1.20:1	WR-04 Waveguide, UG-387/U-M Round Flange
561J-X/387	220-325	3, 6, 10, 20, 30, 40, 50 dB	25 dB	6 dB	1.25:1	1.32:1	WR-03 Waveguide, UG-387/U-M Round Flange

564/566 Series

Cross Guide Directional Couplers

MI-WAVE®

Millimeter Wave Products Inc.

Description

Mi-Wave's 564 Series Cross Guide Coupler consists of two waveguides at right angles to each other, joined by small Coupling slots whose size, location, and orientation determine the Coupling and Directivity of the unit. All ports are available for sampling or injecting energy and are clearly marked to indicate the Coupling direction.

- *Low VSWR*
- *Four-port Device*
- *Rugged Construction*
- *Broadband Operation*



Applications

The 564 Series Cross Guide Directional Couplers provide an efficient means for sampling power or injecting a signal into a waveguide transmission line.

Model Number	Band	Frequency (GHz)	Coupling value (dB)	Directivity (Typ)	VSWR (Typ)	RF Port
564K-X/595	K-Band	18-26.5	20, 30, 40, 50	15 dB	1.15	WR-42 Waveguide, UG-595 Flange
564A-X/599	Ka-Band	26.5-40	20, 30, 40, 50	15 dB	1.15	WR-28 Waveguide, UG-599 Flange
564B-X/383	Q-Band	33-50	20, 30, 40, 50	15 dB	1.15	WR-22 Waveguide, UG-383 Flange
564V-X/385	V-Band	50-75	20, 30, 40, 50	15 dB	1.2	WR-15 Waveguide, UG-385 Flange
564E-X/387	E-Band	60-90	20, 30, 40, 50	15 dB	1.2	WR-12 Waveguide, UG-387 Flange
564W-X/387	W-Band	75-110	20, 30, 40, 50	15 dB	1.2	WR-10 Waveguide, UG-387 Flange
564F-X/387	F-Band	90-140	20, 30, 40, 50	15 dB	1.2	WR-08 Waveguide, UG-387 Flange
564D-X/387	D-Band	110-170	20, 30, 40, 50	14 dB	1.5	WR-6 Waveguide, UG-387 Flange
564G-X/387	G-Band	140-220	20, 30, 40, 50	14 dB	1.5	WR-5 Waveguide, UG-387 Flange

Description

Mi-Wave's 566 Series Cross Guide Coupler Consists of two waveguides at right angles to each other, joined by small Coupling slots whose size, location, and orientation determine the Coupling and Directivity of the unit. All ports are available for sampling or injecting energy and are clearly marked to indicate the Coupling direction.

- *Low Cost*
- *Low VSWR*
- *Four-port Device*
- *Rugged Construction*
- *Broadband Operation*



Applications

The 566 Series Cross Guide Directional Couplers provide an efficient means for sampling power or injecting a signal into a waveguide transmission line.

Model Number	Band	Frequency (GHz)	Coupling Value (X)	Directivity (Typ)	VSWR (Typ)	RF Port
566K-X/595	K-Band	18-26.5	20, 30, 40, 50 dB	15 dB	1.15	WR-42 Waveguide, UG-595
566A-X/599	Ka-Band	26.5-40	20, 30, 40, 50 dB	15 dB	1.15	WR-28 Waveguide, UG-599
566B-X/383	Q-Band	33-50	20, 30, 40, 50 dB	15 dB	1.15	WR-22 Waveguide, UG-383
566U-X/383	U-Band	40-60	20, 30, 40, 50 dB	15 dB	1.15	WR-19 Waveguide, UG-385
566V-X/383	V-Band	50-75	20, 30, 40, 50 dB	15 dB	1.2	WR-15 Waveguide, UG-387

567 Series

Waveguide and Split Block Type Dual-Directional Couplers

MI-WAVE®
Millimeter Wave Products Inc.



Waveguide Coupler



Block Style Coupler

Description

Mi-Wave's 567 Series Dual-directional Couplers are Broadband, broadwall components with a multi-hole Directivity. The 567 Series Couplers are available in 3, 6, 10, 20, 30, 40 and 50 dB Coupling values for standard Bands from 18 to 170.0 GHz in waveguide configuration. 567 also available in split block type configuration from 18 to 325 GHz.

- *High Directivity*
- *Accurate Coupling*
- *Full Bandwidth*

Block Style available in all Bands

Waveguide available in: K, Ka, Q, U, V, E and W

Applications

The 567 Series Dual-directional couplers are used in applications that require precise sampling of both incident and reflected energy. The 3 dB couplers are especially useful in balanced mixer work where Broadband power division of RF and LO signals is required to supply both sides of a balanced mixer unit.

The 3 dB bi-directional couplers can provide full bandwidth power division.

Model Number	Band	Frequency (GHz)	Insertion Loss (Typ)	Coupling Value (X)	Directivity (Typ)	VSWR (Typ)	RF Ports
567K-X/595	K-Band	18-26.5	1 dB	3, 6, 10, 20, 30, 40, 50 dB	40 dB	1.12	WR-42 Waveguide, UG-595/U Flange
567A-X/599	Ka-Band	26.5-40	1 dB	3, 6, 10, 20, 30, 40, 50 dB	40 dB	1.12	WR-28 Waveguide, UG-599/U Flange
567B-X/719	Q-Band	33-50	1 dB	3, 6, 10, 20, 30, 40, 50 dB	40 dB	1.12	WR-22 Waveguide, UG-719/U Flange
567U-X/383	U-Band	40-60	1 dB	3, 6, 10, 20, 30, 40, 50 dB	40 dB	1.15	WR-19 Waveguide, UG-383/U Flange
567V-X/385	V-Band	50-75	1 dB	3, 6, 10, 20, 30, 40, 50 dB	40 dB	1.15	WR-15 Waveguide, UG-385/U Flange
567E-X/387	E-Band	60-90	1.5 dB	3, 6, 10, 20, 30, 40, 50 dB	40 dB	1.15	WR-12 Waveguide, UG-387/U Flange
567W-X/387	W-Band	75-110	1.5 dB	3, 6, 10, 20, 30, 40, 50 dB	40 dB	1.17	WR-10 Waveguide, UG-387/U Flange
567F-X/387	F-Band	75-110	1.5 dB	3, 6, 10, 20, 30, 40, 50 dB	40 dB	1.17	WR-8 Waveguide, UG-387/U-M Flange
567D-X/387	D-Band	75-110	1.5 dB	3, 6, 10, 20, 30, 40, 50 dB	40 dB	1.17	WR-6 Waveguide, UG-387/U-M Flange
567G-X/387	G-Band	75-110	1.5 dB	3, 6, 10, 20, 30, 40, 50 dB	40 dB	1.17	WR-5 Waveguide, UG-387/U-M Flange

580 Series

Terminations

MI-WAVE®
Millimeter Wave Products Inc.

Description

Mi-Wave's 580 Series Terminations are designed with standard waveguide flanges for use from 8.2 to 500 GHz. Each unit consists of a short length of waveguide and an integral matched terminal load. Individual resistive dielectric loads are tapered to precise wedge configurations for maximum effective energy absorption. The gradual taper provides a Low VSWR over the full Bandwidth.

- *Low VSWR*
- *Compact Sizes*
- *Full Bandwidths*
- *Available for Low Power and Medium Power Applications*



Applications

The 580 Series Terminations are used in experimental and developmental test sets where a Low VSWR wave-guide load is essential for valid and accurate measurements. These terminations will ensure precise measurement of the VSWR resulting from insertion of various waveguide components into a system.

Model Number	Band	Frequency (GHz)	Power Handling (CW)	VSWR (Typ)	RF Ports
581X/UG39	X-Band	8.2-12.4	10 Watts	1.05:1	WR-90 Waveguide, UG-39/U Flange
580K/595	K-Band	18-26.5	5 Watts	1:1	WR-42 Waveguide, UG-595/U Flange
580(34)/595	WR-34	22-33	5 Watts	1:1	WR-34 Waveguide, UG-595 Flange
580A/381	Ka-Band	26.5-40	5 Watts	1:1	WR-28 Waveguide, UG-381/U Flange
580B/383	Q-Band	33-50	4 Watts	1:1	WR-22 Waveguide, UG-383/U Flange
580U/383	U-Band	40-60	2 Watts	1:1	WR-19 Waveguide, UG-383/U Flange
580V/385	V-Band	50-75	1 Watts	1:1	WR-15 Waveguide, UG-385/U Flange
580E/387	E-Band	60-90	0.5 Watts	1:1	WR-12 Waveguide, UG-387/U Flange
580W/387	W-Band	75-110	0.3 Watts	1:1	WR-10 Waveguide, UG-387/U Flange
580F/387	F-Band	90-140	0.2 Watts	1:1	WR-8 Waveguide, UG-387/U Flange
580D/387	D-Band	110-170	0.1Watts	1:1	WR-6 Waveguide, UG-387/U-M Flange
580G/387	G-Band	140-220	0.1 Watts	1:15:1	WR-5 Waveguide, UG-387/U Flange
580H/387	H-Band	170-260	0.05 Watts	1:15:1	WR-4 Waveguide, UG-387/U Flange
580J/387	J-Band	220-325	0.02 Watts	1:15:1	WR-3 Waveguide, UG-387/U Flange

581 Series

Medium Power Load Terminations

MI-WAVE®
Millimeter Wave Products Inc.



Description

Mi-Wave's 581 Series Terminations are designed with standard waveguide flanges for use from 26.5 to 260 GHz. Each unit consists of a short length of waveguide and an integral matched terminal load. Individual resistive dielectric loads are tapered to precise wedge configurations for maximum effective energy absorption. The gradual taper provides a Low VSWR over the full Bandwidth.

- *Low VSWR*
- *Compact Size*
- *Full Bandwidths*
- *Available for Low Power and Medium Power Applications*

PLEASE NOTE:

Please note: for higher power requirements 582 Series and up to 100 watts CW, please consult Mi-Wave for technical specifications.

Applications

The 581 Series Terminations are used in experimental and developmental test sets where a Low VSWR wave-guide load is essential for valid and accurate measurements. These terminations will ensure precise measurement of the VSWR resulting from insertion of various waveguide components into a system.

Model	Band	Frequency (GHz)	Power Handling (CW)	VSWR (Typ)	RF Ports
581Ku/419	Ku-Band	12.4-18	20 Watts	1.10:1	WR-62 Waveguide, UG-419 Flange
581K/595	K-Band	18-26.5	15 Watts	1.10:1	WR-42 Waveguide, UG-595/U Flange
581A/599	Ka-Band	26.5-40	10 Watts	1.10:1	WR-28 Waveguide, UG-599/U Flange
581B/383	Q-Band	33-50	7 Watts	1.10:1	WR-22 Waveguide, UG-383/U Flange
581U/383	U-Band	40-60	4 Watts	1.10:1	WR-19 Waveguide, UG-383/U Flange
581V/385	V-Band	50-75	3 Watts	1.10:1	WR-15 Waveguide, UG-385/U Flange
581E/387	E-Band	60-90	1 Watts	1.10:1	WR-12 Waveguide, UG-387/U Flange
581W/387	W-Band	75-110	1 Watts	1.10:1	WR-10 Waveguide, UG-387/U Flange
581F/387	F-Band	90-140	0.4 Watts	1.10:1	WR-8 Waveguide, UG-387/U Flange
581D/387	D-Band	110-170	0.3 Watts	1.15:1	WR-6 Waveguide, UG-387/U-M Flange
581G/387	G-Band	140-220	0.2 Watts	1.15:1	WR-5 Waveguide, UG-387/U-M Flange
581H/387	H-Band	170-260	0.2 Watts	1.15:1	WR-4 Waveguide, UG-387/U Flange

582 Series

High Power Load Terminations

MI-WAVE®
Millimeter Wave Products Inc.

Description

Mi-Wave's 582 Series Terminations are designed with standard waveguide flanges for use from 8.2 to 220 GHz. Each unit consists of a short length of waveguide and an integral matched terminal load. Individual resistive dielectric loads are tapered to precise wedge configurations for maximum effective energy absorption. The gradual taper provides a Low VSWR over the full Bandwidth.

- *Low VSWR*
- *Compact Sizes*
- *Full Bandwidths*
- *Available for High Power up to 250 Watts CW Applications*

Power requirements for the 482 Series is up to 250 Watts CW, please consult Mi-Wave for other power availabilities and further technical information.

Applications

The 582 Series Terminations are used in experimental and developmental test sets where a Low VSWR wave-guide load is essential for valid and accurate measurements. These terminations will ensure precise measurement of the VSWR resulting from insertion of various waveguide components into a system.



Model Number	Band	Frequency (GHz)	Power Handling (CW)	VSWR (Typ)	RF Ports
582X/39	X-Band	8.2-12.4	100 Watts	1.10:1	WR-90 Waveguide, UG-39/U Flange
582Ku/595	Ku-Band	12.4-18	100 Watts	1.10:1	WR-42 Waveguide, UG-595/U Flange
582A/599	Ka-Band	26.5-40	75 Watts	1.10:1	WR-28 Waveguide, UG-381/U Flange
582B/383	Q-Band	33-50	50 Watts	1.10:1	WR-22 Waveguide, UG-383/U Flange
582U/383	U-Band	40-60	10 Watts	1.10:1	WR-19 Waveguide, UG-383/U Flange
582V/385	V-Band	50-75	10 Watts	1.10:1	WR-15 Waveguide, UG-385/U Flange
582E/387	E-Band	60-90	10 Watts	1.10:1	WR-12 Waveguide, UG-387/U Flange
582W/387	W-Band	75-110	10 Watts	1.10:1	WR-10 Waveguide, UG-387/U Flange
582F/387	F-Band	90-140	5.0 Watts	1.15:1	WR-8 Waveguide, UG-387/U Flange
582D/387	D-Band	110-170	2.0 Watts	1.15:1	WR-6 Waveguide, UG-387/U-M Flange
582G/387	G-Band	140-220	1.0 Watts	1.15:1	WR-5 Waveguide, UG-387/U Flange

585 Series

Sliding Matched Terminations

MI-WAVE®

Millimeter Wave Products Inc.



Description

Mi-Wave's 585 Series Sliding Matched load consists micrometer drive. The load is machined to precise tolerances to permit the close fit necessary for sliding without binding.

- *Low VSWR*
- *Precision Adjustment*

Applications

The 585 Series Sliding matched loads are designed for use in test and development sets where Low VSWR is being measured. By changing the position of the sliding load, the test engineer can determine a minimum/maximum VSWR due to the phasing between the VSWR of the load and VSWR of the unit under test.

This min/max VSWR is used to determine the true VSWR of the unit under test. The 585 Series loads are also used to measure coupler Directivity and residual VSWR in slotted line or other reflection measuring devices.

Model Number	Band	Frequency Low (GHz)	Frequency High (GHz)	Average Power (Typ)	VSWR (Typ)	RF Ports
585K/595	K-Band	18	26.5	1.0	1.05:1	WR-42 Waveguide, UG-595/U Flange
585(34)/595	WR-34	22	33	1.0	1.05:1	WR-34 Waveguide, UG-595/U Flange
585A/381	Ka-Band	26.5	40	1.0	1.05:1	WR-28 Waveguide, UG-381/U Flange
585B/383	Q-Band	33	50	5.0	1.05:1	WR-22 Waveguide, UG-383/U Flange
585U/387	U-Band	40	60	0.7	1.06:1	WR-19 Waveguide, UG-383/U Flange
585V/387	V-Band	50	75	0.3	1.06:1	WR-15 Waveguide, UG-385/U Flange
585E/387	E-Band	60	90	0.3	1.06:1	WR-12 Waveguide, UG-387/U Flange
585W/387	W-Band	75	110	0.2	1.08:1	WR-10 Waveguide, UG-387/U Flange
585F/387	F-Band	90	140	0.1	1.08:1	WR-8 Waveguide, UG-387/U Flange
585D/387	D-Band	110	170	0.1	1.08:1	WR-6 Waveguide, UG-387/U-M Flange
585G/387	G-Band	140	220	0.1	1.10:1	WR-5 Waveguide, UG-387/U Flange

590/595 Series

Adjustable and Fixed Waveguide Short Circuits

MI-WAVE®
Millimeter Wave Products Inc.

Description

Mi-Wave's 585 Series Sliding Matched load consists micrometer drive. The load is machined to precise tolerances to permit the close fit necessary for sliding without binding.

The non-contacting choke type short circuit is designed to operate with high electrical stability over a broad range of frequencies. The micrometer drive provides smooth, accurate positional tuning over the entire distance traveled and a positive locking device ensures continued setting reliability.

The 595 Series is a fixed short circuit is available is available from 8.2 to 325 GHz.

- Full Waveguide Coverage
- Non-contacting Choke Type Short
- Precision Micrometer Tuning and Readout
- Minimum Travel of One-half Wavelength at Lowest Operating Frequency

590 Adjustable Short Circuits



595 Fixed Short Circuits



Model Number	Band	Frequency (GHz)	Type	RF Ports
590(34)/595	WR-34	22-33	Adjustable	WR-34 Waveguide, UG-595/U Flange
590A/381	Ka-Band	26.5-40	Adjustable	WR-22 Waveguide, UG-383/U Flange
590B/383	Q-Band	33-50	Adjustable	WR-19 Waveguide, UG-383/U Flange
590U/387	U-Band	40-60	Adjustable	WR-15 Waveguide, UG-385/U Flange
590V/387	V-Band	50-75	Adjustable	WR-12 Waveguide, UG-387/U Flange
590E/387	E-Band	60-90	Adjustable	WR-10 Waveguide, UG-387/U Flange
590W/387	W-Band	75-110	Adjustable	WR-8 Waveguide, UG-387/U Flange
590F/387	F-Band	90-140	Adjustable	WR-6 Waveguide, UG-387/U-M Flange
590D/387	D-Band	110-170	Adjustable	WR-5 Waveguide, UG-387/U Flange
590G/387	G-Band	140-220	Adjustable	WR-5 Waveguide, UG-387/U Flange

Model Number	Band	Frequency (GHz)	Type	RF Ports
595X/39	Ku-Band	12.4-18	Fixed	WR-90 Waveguide, UG-39/U Flange
595Ku/595	Ku-Band	12.4-18	Fixed	WR-34 Waveguide, UG-595/U Flange
595K/595	K-Band	18-27	Fixed	WR-34 Waveguide, UG-595/U Flange
595A/599	Ka-Band	26.5-40	Fixed	WR-28 Waveguide, UG-381/U Flange
595B/383	Q-Band	33-50	Fixed	WR-22 Waveguide, UG-383/U Flange
595U/383	U-Band	40-60	Fixed	WR-19 Waveguide, UG-383/U Flange
595V/385	V-Band	50-75	Fixed	WR-15 Waveguide, UG-385/U Flange
595E/387	E-Band	60-90	Fixed	WR-12 Waveguide, UG-387/U Flange
595W/387	W-Band	75-110	Fixed	WR-10 Waveguide, UG-387/U Flange
595F/387	F-Band	90-140	Fixed	WR-8 Waveguide, UG-387/U Flange
595D/387	D-Band	110-170	Fixed	WR-6 Waveguide, UG-387/U-M Flange
595G/387	G-Band	140-220	Fixed	WR-5 Waveguide, UG-387/U Flange

592 Series

Waveguide Shims and Spacers

MI-WAVE®
Millimeter Wave Products Inc.

Description

Miwave's Series 592 series Waveguide Shims and Spacers are devices that reduce the connection gaps between waveguide components. Mi-wave offers waveguide shims and spacers from 8 GHz to 325 GHz.



Model Number	Band	Frequency (GHz)	Type	RF Ports	Material	Finish
592X-XXXmm/39	X-Band	8.2-12.4 GHz	Customer to specify thickness XXX	WR-90 Waveguide, UG-39/U Flange	Aluminum/Brass	Gold Plated
592Ku-XXXmm/419	Ku-Band	12-18 GHz	Customer to specify thickness XXX	WR-62 Waveguide, UG-419/U Flange	Aluminum/Brass	Gold Plated
592K-XXXmm/595	K-Band	18-26.5 GHz	Customer to specify thickness XXX	WR-42 Waveguide, UG-595/U Flange	Aluminum/Brass	Gold Plated
592A-XXXmm/599	A-Band	26.5-40 GHz	Customer to specify thickness XXX	WR-28 Waveguide, UG-599/U Flange	Aluminum/Brass	Gold Plated
592B-XXXmm/383	B-Band	33-50 GHz	Customer to specify thickness XXX	WR-22 Waveguide, UG-383/U Flange	Aluminum/Brass	Gold Plated
592U-XXXmm/383	U-Band	40-60 GHz	Customer to specify thickness XXX	WR-19 Waveguide, UG-383/U-M Flange	Aluminum/Brass	Gold Plated
592V-XXXmm/385	V-Band	50-75 GHz	Customer to specify thickness XXX	WR-15 Waveguide, UG-385/U-M Flange	Aluminum/Brass	Gold Plated
592E-XXXmm/387	E-Band	60-90 GHz	Customer to specify thickness XXX	WR-12 Waveguide, UG-387/U Flange	Aluminum/Brass	Gold Plated
592W-XXXmm/387	W-Band	75-110 GHz	Customer to specify thickness XXX	WR-10 Waveguide, UG-387/U-M Flange	Aluminum/Brass	Gold Plated
592F-XXXmm/387	F-Band	90-140 GHz	Customer to specify thickness XXX	WR-08 Waveguide, UG-387/U-M Flange	Aluminum/Brass	Gold Plated
592D-XXXmm/387	D-Band	110-170 GHz	Customer to specify thickness XXX	WR-06 Waveguide, UG-387/U-M Flange	Aluminum/Brass	Gold Plated
592G-XXXmm/387	G-Band	140-220 GHz	Customer to specify thickness XXX	WR-05 Waveguide, UG-387/U-M Flange	Aluminum/Brass	Gold Plated
592H-XXXmm/387	H-Band	170-260 GHz	Customer to specify thickness XXX	WR-04 Waveguide, UG-387/U Flange	Aluminum/Brass	Gold Plated
592J-XXXmm/387	J-Band	220-325 GHz	Customer to specify thickness XXX	WR-3 Waveguide, UG-387/U-M Flange	Aluminum/Brass	Gold Plated

604/608 Series

Four-way/Eight-way Power Divider

MI-WAVE®
Millimeter Wave Products Inc.

Description

Mi-Wave's 604 Series Four-way Power Divider, inherently-matched 3 dB power splitting devices. Available in standard waveguide sizes from 18.0 to 325 GHz, these units are capable of in-phase splitting.

Mi-Wave's 608 Series Eight-way Power Divider, inherently-matched 3 dB power splitting devices. Available in standard waveguide sizes from 18.0 to 220 GHz., these units are capable of in-phase splitting.

- *Low VSWR*
- *High Isolation*
- *Minimum Size*
- *High Reliability*
- *Equal Power Split*
- *Low Insertion Loss*
- *Rugged Construction*



604 Four Way Power Divider



608 Eight Way Power Divider

Applications

The 604 Series Four-way/ 608 Series Eight-way Power Divider are used in:

- Power Splitting
- Power Combining

Model Number	Band	Frequency (GHz)	Isolation (E-H)	Divider	Insertion Loss (Typ)	Power Imbalance (± dB)	RF Ports
604K/595	K-Band	18-26.5	20	4-Way	1.0 dB	0.5 dB	WR-42 Waveguide, UG-595/U Flange
604A/599	Ka-Band	26.5-40	20	4-Way	1.5 dB	0.5 dB	WR-28 Waveguide, UG-381/U Flange
604B/383	Q-Band	33-50	20	4-Way	2.0 dB	0.5 dB	WR-22 Waveguide, UG-383/U Flange
604U/383	U-Band	40-60	20	4-Way	2.5 dB	0.7 dB	WR-19 Waveguide, UG-383/U Flange
604V/385	V-Band	50-75	20	4-Way	2.7 dB	0.8 dB	WR-15 Waveguide, UG-385/U Flange
604E/387	E-Band	60-90	20	4-Way	2.8 dB	0.8 dB	WR-12 Waveguide, UG-387/U Flange
604W/387	W-Band	75-110	20	4-Way	3.0 dB	0.8 dB	WR-10 Waveguide, UG-387/U Flange
604F/387	F-Band	90-140	20	4-Way	3.0 dB	1.2 dB	WR-8 Waveguide, UG-387/U Flange
604D/387	D-Band	110-170	20	4-Way	3.5 dB	1.3 dB	WR-6 Waveguide, UG-387/U-M Flange
604G/387	G-Band	140-220	20	4-Way	4.0dB	1.6 dB	WR-5 Waveguide, UG-387/U Flange
604H/387	H-Band	170-260	22	4-Way	5.0 dB	1.6 dB	WR-4 Waveguide, UG-387/U Flange
604J/387	J-Band	220-325	20	4-Way	6.0 dB	2.1 dB	WR-3 Waveguide, UG-387/U Flange

Model Number	Band	Frequency (GHz)	Isolation (E-H)	Divider	Insertion Loss (Typ)	Power Imbalance (± dB)	RF Ports
608K/595	K-Band	18-26.5	20	8-Way	1.5 dB	0.8 dB	WR-42 Waveguide, UG-595/U Flange
608A/599	Ka-Band	26.5-40	20	8-Way	2.0 dB	1 dB	WR-28 Waveguide, UG-381/U Flange
608B/383	Q-Band	33-50	20	8-Way	2.5 dB	1 dB	WR-22 Waveguide, UG-383/U Flange
608U/383	U-Band	40-60	20	8-Way	3.0 dB	1 dB	WR-19 Waveguide, UG-383/U Flange
608V/385	V-Band	50-75	20	8-Way	3.4dB	1 dB	WR-15 Waveguide, UG-385/U Flange
608E/387	E-Band	60-90	20	8-Way	3.6 dB	1 dB	WR-12 Waveguide, UG-387/U Flange
608W/387	W-Band	75-110	20	8-Way	4.0 dB	1 dB	WR-10 Waveguide, UG-387/U Flange
608F/387	F-Band	90-140	20	8-Way	4.2 dB	1 dB	WR-8 Waveguide, UG-387/U Flange
608D/387	D-Band	110-170	20	8-Way	4.5 dB	1 dB	WR-6 Waveguide, UG-387/U-M Flange
608G/387	G-Band	140-220	20	8-Way	5.0 dB	1 dB	WR-5 Waveguide, UG-387/U Flange

620 Series

E/H Plane Tuners

MI-WAVE®
Millimeter Wave Products Inc.



Description

Mi-Wave's 620 Series E/H Plane Tuners are hybrid tee sections available in standard waveguide sizes for operation from 8.2 to 325 GHz. The devices feature micrometer-driven tunable shorts in both the E-plane and H-plane arms for accurate tuning and reproducing settings. The internal short circuits are non-contacting, choke-type plungers that provide a highly stable electrical short. Locking devices ensure continued setting reliability under all normal conditions of test bench shock and vibration. The shorts travel a minimum of one-half wavelength at the lowest frequency.

- *Micrometer Driven*
- *Non-contacting Choke-type Short Circuits*

Applications

The 620 Series Tuners are excellent millimeter wave impedance matching networks designed to provide the reliable mismatch control required in most experimental and developmental test applications. These tuners introduce discontinuities into the waveguide transmission line for simultaneous control of both phase and amplitude of the RF reflection coefficient. They can be used as matching devices to cancel reflection in transmission lines or to match detectors, terminations, and similar components.

Model Number	Band	Frequency (GHz)	RF Ports
620X/39	X-Band	8.2-12.4	WR-90 Waveguide, UG-39/U Flange
620Ku/419	Ku-Band	12.4-18	WR-62 Waveguide, UG-419/U Flange
620K/595	K-Band	18-26.5	WR-42 Waveguide, UG-595/U Flange
620A/599	Ka-Band	26.5-40	WR-28 Waveguide, UG-381/U Flange
620B/383	Q-Band	33-50	WR-22 Waveguide, UG-383/U Flange
620U/383	U-Band	40-60	WR-19 Waveguide, UG-383/U Flange
620V/385	V-Band	50-75	WR-15 Waveguide, UG-385/U Flange
620E/387	E-Band	60-90	WR-12 Waveguide, UG-387/U Flange
620W/387	W-Band	75-110	WR-10 Waveguide, UG-387/U Flange
620F/387	F-Band	90-140	WR-8 Waveguide, UG-387/U Flange
620D/387	D-Band	110-170	WR-6 Waveguide, UG-387/U-M Flange
620G/387	G-Band	140-220	WR-5 Waveguide, UG-387/U Flange
620H/387	H-Band	170-260	WR-4 Waveguide, UG-387/U Flange
620J/387	J-Band	220-325	WR-3 Waveguide, UG-387/U Flange

635 Series

Magic Tees

MI-WAVE®
Millimeter Wave Products Inc.

Description

Mi-Wave's 635 Series E/H Magic Tees consist of three mutually perpendicular flanged sections of a standard waveguide. Two of these sections are symmetrically located on the broad and narrow walls of the main tee section to provide E-plane and H-plane connections.

- *Equal Power Division*
- *Available from 8.2 to 325GHz*
- *High Isolation Provided by Symmetrical Construction*

The internal geometry of these hybrids provides a power-dividing and phase-inverting characteristic. Power applied to the shunt H-plane arm is divided between the two in-line ports of the main tee section to result in equal power, in-phase output signals. Power applied to the series E-plane arm is also divided between these two ports, but with a phase reversal which provides equal power, opposite-phase outputs. With symmetrical construction, good Isolation is maintained between the E-plane and H-plane arms.

The 635 Series Hybrid Tees are available in standard wave-guide sizes from 8.2 to 325 GHz.

Applications

The 635 Series Hybrid Tees are four-port transmission line components designed for basic power-splitting and mixing applications. These devices are useful as integral parts of RF bridge circuits for routine impedance comparisons and reflection coefficient measurements or as power dividers and isolators in radar balanced mixer circuits.

For matched applications, Mi-Wave recommends 635 Series Magic Tee.



Model Number	Band	Frequency (GHz)	Isolation (E-H) (Typ)	Insertion Loss (Typ)	Power Imbalance (±)	RF Ports
635X/39	X-Band	8.2-12.1	35 dB	0.5 dB	0.5 dB	WR-90 Waveguide, UG-39/U Flange
635K/595	K-Band	18-26.5	35 dB	0.6 dB	0.5 dB	WR-42 Waveguide, UG-595/U Flange
635A/599	Ka-Band	26.5-40	30 dB	0.7 dB	0.5 dB	WR-28 Waveguide, UG-381/U Flange
635B/383	Q-Band	33-50	30 dB	0.7 dB	0.5 dB	WR-22 Waveguide, UG-383/U Flange
635U/383	U-Band	40-60	30 dB	1 dB	0.5 dB	WR-19 Waveguide, UG-383/U Flange
635V/385	V-Band	50-75	30 dB	1 dB	0.5 dB	WR-15 Waveguide, UG-385/U Flange
635E/387	E-Band	60-90	30 dB	1 dB	0.5 dB	WR-12 Waveguide, UG-387/U Flange
635W/387	W-Band	75-110	20 dB	1.5 dB	0.5 dB	WR-10 Waveguide, UG-387/U Flange
635F/387	F-Band	90-140	25 dB	1.7 dB	0.8 dB	WR-8 Waveguide, UG-387/U Flange
635D/387	D-Band	110-170	20 dB	2.5 dB	0.5 dB	WR-6 Waveguide, UG-387/U-M Flange
635G/387	G-Band	140-220	20 dB	3 dB	1.5 dB	WR-5 Waveguide, UG-387/U Flange
635H/387	H-Band	170-260	20 dB	4 dB	1.5 dB	WR-4 Waveguide, UG-387/U Flange
635J/387	J-Band	220-325	15 dB	5 dB	1.5 dB	WR-3 Waveguide, UG-387/U Flange

630/640/650 Series

640 E-plane Series 650 H-plane Series Tees

MI-WAVE®

Millimeter Wave Products Inc.



Description

Mi-Wave's 630 Series Block Type Tee available in E and H Planes.

Mi-Wave's 640 Series E-plane Tees consist of a length of standard flanged Waveguide, a perpendicular E-plane Coupling arm symmetrically located on the broad waveguide wall. Input power is divided equally and in opposite phase between the two outputs.

Similarly, the 650 Series H-plane Tees feature an H-plane Coupling arm located on the narrow waveguide wall. Power at the Coupling arm input is divided into equal signals in phase at the main outputs. These devices are available in standard waveguide sizes from 8.2 to 110 GHz.

- *Unmatched ports*
- *Geometrical Symmetry*
- *Available from 8.2 to 110 GHz*
- *Equal Power Division Between the Two Outputs*

Model Number	Band	Frequency (GHz)	Plane	RF Ports
630X/39	X-Band	8.2-12.1	E-Plane/H-Plane	WR-90 Waveguide, UG-39/U Flange
630K/595	K-Band	18-26.5	E-Plane/H-Plane	WR-42 Waveguide, UG-595/U Flange
630A/599	Ka-Band	26.5-40	E-Plane/H-Plane	WR-28 Waveguide, UG-381/U Flange
630B/383	Q-Band	33-50	E-Plane/H-Plane	WR-22 Waveguide, UG-383/U Flange
630U/383	U-Band	40-60	E-Plane/H-Plane	WR-19 Waveguide, UG-383/U Flange
630V/385	V-Band	50-75	E-Plane/H-Plane	WR-15 Waveguide, UG-385/U Flange
630E/387	E-Band	60-90	E-Plane/H-Plane	WR-12 Waveguide, UG-387/U Flange
630W/387	W-Band	75-110	E-Plane/H-Plane	WR-10 Waveguide, UG-387/U Flange

Model Number	Band	Frequency (GHz)	Plane	RF Ports
640X/39	X-Band	8.2-12.1	E-Plane	WR-90 Waveguide, UG-39/U Flange
640K/595	K-Band	18-26.5	E-Plane	WR-42 Waveguide, UG-595/U Flange
640A/599	Ka-Band	26.5-40	E-Plane	WR-28 Waveguide, UG-381/U Flange
640B/383	Q-Band	33-50	E-Plane	WR-22 Waveguide, UG-383/U Flange
640U/383	U-Band	40-60	E-Plane	WR-19 Waveguide, UG-383/U Flange
640V/385	V-Band	50-75	E-Plane	WR-15 Waveguide, UG-385/U Flange
640E/387	E-Band	60-90	E-Plane	WR-12 Waveguide, UG-387/U Flange
640W/387	W-Band	75-110	E-Plane	WR-10 Waveguide, UG-387/U Flange

Model Number	Band	Frequency (GHz)	Plane	RF Ports
650X/39	X-Band	8.2-12.1	H-Plane	WR-90 Waveguide, UG-39/U Flange
650K/595	K-Band	18-26.5	H-Plane	WR-42 Waveguide, UG-595/U Flange
650A/599	Ka-Band	26.5-40	H-Plane	WR-28 Waveguide, UG-381/U Flange
650B/383	Q-Band	33-50	H-Plane	WR-22 Waveguide, UG-383/U Flange
650U/383	U-Band	40-60	H-Plane	WR-19 Waveguide, UG-383/U Flange
650V/385	V-Band	50-75	H-Plane	WR-15 Waveguide, UG-385/U Flange
650E/387	E-Band	60-90	H-Plane	WR-12 Waveguide, UG-387/U Flange
650W/387	W-Band	75-110	H-Plane	WR-10 Waveguide, UG-387/U Flange

66X/67X Series

E-plane Bends and H-Plane Bends

MI-WAVE®
Millimeter Wave Products Inc.

Description

Mi-Wave's 66X and 67X Series E-plane Bends are sections of high-precision waveguide accuratetaped to either 30° (661 and 671), 45° (665 and 675), 60° (662 and 672), or 90° (660 and 670) bends. Special angles, radii, and configurations for particular application can be developed on special order. All E-plane and H-plane Series Bends are available from 18 to 325 GHz.

- Available from 8.2 to 325 GHz
- Additional Radius and Angle Bends by Special Order
- Smooth Precision Bends Minimize Energy Reflections

Applications

The E-plane and H-plane bends series provide accurate offsets and directional changes in waveguide transmission lines for test and developmental applications. Manufactured to rigid specifications, these transmission line components provide minimum detrimental effects on the

660 E-Plane



670 H-Plane



Model Number	Band	Frequency (GHz)	Degree	Plane	VSWR (Typ)	RF Ports
66(0/1/2/5)K/595	K-Band	18-26.5	90°, 30°, 60°, 45°	E-Plane	1.06:1	WR-42 Waveguide, UG-595/U Flange
66(0/1/2/5)A/599	Ka-Band	26.5-40	90°, 30°, 60°, 45°	E-Plane	1.06:1	WR-28 Waveguide, UG-599/U Flange
66(0/1/2/5)B/383	Q-Band	33-50	90°, 30°, 60°, 45°	E-Plane	1.06:1	WR-22 Waveguide, UG-383/U Flange
66(0/1/2/5)U/383	U-Band	40-60	90°, 30°, 60°, 45°	E-Plane	1.12:1	WR-19 Waveguide, UG-383/U Flange
66(0/1/2/5)V/385	V-Band	50-75	90°, 30°, 60°, 45°	E-Plane	1.15:1	WR-15 Waveguide, UG-385/U Flange
66(0/1/2/5)E/387	E-Band	60-90	90°, 30°, 60°, 45°	E-Plane	1.15:1	WR-12 Waveguide, UG-387/U Flange
66(0/1/2/5)W/387	W-Band	75-110	90°, 30°, 60°, 45°	E-Plane	1.15:1	WR-10 Waveguide, UG-387/U Flange
66(0/1/2/5)F/387	F-Band	90-140	90°, 30°, 60°, 45°	E-Plane	1.15:1	WR-8 Waveguide, UG-387/U Flange
66(0/1/2/5)D/387	D-Band	110-170	90°, 30°, 60°, 45°	E-Plane	1.15:1	WR-6 Waveguide, UG-387/U-M Flange
66(0/1/2/5)G/387	G-Band	140-220	90°, 30°, 60°, 45°	E-Plane	1.15:1	WR-5 Waveguide, UG-387/U Flange
66(0/1/2/5)H/387	H-Band	170-260	90°, 30°, 60°, 45°	E-Plane	1.15:1	WR-4 Waveguide, UG-387/U Flange
66(0/1/2/5)J/387	J-Band	220-325	90°, 30°, 60°, 45°	E-Plane	1.15:1	WR-3 Waveguide, UG-387/U Flange

Model Number	Band	Frequency (GHz)	Degree	Plane	VSWR (Typ)	RF Ports
67(0/1/2/5)K/595	K-Band	18-26.5	90°, 30°, 60°, 45°	H-Plane	1.06:1	WR-42 Waveguide, UG-595/U Flange
67(0/1/2/5)A/599	Ka-Band	26.5-40	90°, 30°, 60°, 45°	H-Plane	1.06:1	WR-28 Waveguide, UG-599/U Flange
67(0/1/2/5)B/383	Q-Band	33-50	90°, 30°, 60°, 45°	H-Plane	1.06:1	WR-22 Waveguide, UG-383/U Flange
67(0/1/2/5)U/383	U-Band	40-60	90°, 30°, 60°, 45°	H-Plane	1.12:1	WR-19 Waveguide, UG-383/U Flange
67(0/1/2/5)V/385	V-Band	50-75	90°, 30°, 60°, 45°	H-Plane	1.15:1	WR-15 Waveguide, UG-385/U Flange
67(0/1/2/5)E/387	E-Band	60-90	90°, 30°, 60°, 45°	H-Plane	1.15:1	WR-12 Waveguide, UG-387/U Flange
67(0/1/2/5)W/387	W-Band	75-110	90°, 30°, 60°, 45°	H-Plane	1.15:1	WR-10 Waveguide, UG-387/U Flange
67(0/1/2/5)F/387	F-Band	90-140	90°, 30°, 60°, 45°	H-Plane	1.15:1	WR-8 Waveguide, UG-387/U Flange
67(0/1/2/5)D/387	D-Band	110-170	90°, 30°, 60°, 45°	H-Plane	1.15:1	WR-6 Waveguide, UG-387/U-M Flange
67(0/1/2/5)G/387	G-Band	140-220	90°, 30°, 60°, 45°	H-Plane	1.15:1	WR-5 Waveguide, UG-387/U Flange
67(0/1/2/5)H/387	H-Band	170-260	90°, 30°, 60°, 45°	H-Plane	1.15:1	WR-4 Waveguide, UG-387/U Flange
67(0/1/2/5)J/387	J-Band	220-325	90°, 30°, 60°, 45°	H-Plane	1.15:1	WR-3 Waveguide, UG-387/U Flange

680/681 Series

45° and 90° Twists

MI-WAVE®
Millimeter Wave Products Inc.

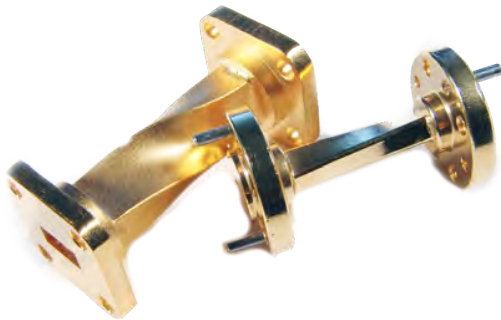

Description

Mi-Wave's 680 Series Twists are short sections of standard flanged Waveguide, left-hand or right hand

45° twist configurations while the

681 Series Twists provide 90° twist configurations. The units are available in standard waveguide sizes from 18 to 325 GHz. Please be sure to specify the left-hand or right-hand configuration when ordering.

- *Smooth 45°/90° Polarization Changes for Minimum Energy Reflection.*

Applications

The 680 Series and the 681 Series waveguide twists are designed to provide changes in waveguide orientation with minimum energy loss and reflections. As integral parts in many of Mi-Wave's ferrite devices, these twists efficiently adapt polarization-rotated RF fields to the orientation of the remaining transmission line components.

Model Number	Band	Frequency (GHz)	Rotation	Configuration	VSWR (Typ)	RF Ports
680K/595	K-Band	18-26.5	45°	Left or Right	1.06:1	WR-42 Waveguide, UG-595/U Flange
680A/599	Ka-Band	26.5-40	45°	Left or Right	1.06:1	WR-28 Waveguide, UG-599/U Flange
680B/383	Q-Band	33-50	45°	Left or Right	1.06:1	WR-22 Waveguide, UG-383/U Flange
680U/383	U-Band	40-60	45°	Left or Right	1.12:1	WR-19 Waveguide, UG-383/U Flange
680V/385	V-Band	50-75	45°	Left or Right	1.15:1	WR-15 Waveguide, UG-385/U Flange
680E/387	E-Band	60-90	45°	Left or Right	1.15:1	WR-12 Waveguide, UG-387/U Flange
680W/387	W-Band	75-110	45°	Left or Right	1.15:1	WR-10 Waveguide, UG-387/U Flange
680F/387	F-Band	90-140	45°	Left or Right	1.15:1	WR-8 Waveguide, UG-387/U Flange
680D/387	D-Band	110-170	45°	Left or Right	1.15:1	WR-6 Waveguide, UG-387/U-M Flange
680G/387	G-Band	140-220	45°	Left or Right	1.15:1	WR-5 Waveguide, UG-387/U Flange
680H/387	H-Band	170-260	45°	Left or Right	1.15:1	WR-4 Waveguide, UG-387/U Flange
680J/387	J-Band	220-325	45°	Left or Right	1.15:1	WR-3 Waveguide, UG-387/U Flange

Model Number	Band	Frequency (GHz)	Rotation	Configuration	VSWR (Typ)	RF Ports
681K/595	K-Band	18-26.5	90°	Left or Right	1.06:1	WR-42 Waveguide, UG-595/U Flange
681A/599	Ka-Band	26.5-40	90°	Left or Right	1.06:1	WR-28 Waveguide, UG-599/U Flange
681B/383	Q-Band	33-50	90°	Left or Right	1.06:1	WR-22 Waveguide, UG-383/U Flange
681U/383	U-Band	40-60	90°	Left or Right	1.12:1	WR-19 Waveguide, UG-383/U Flange
681V/385	V-Band	50-75	90°	Left or Right	1.15:1	WR-15 Waveguide, UG-385/U Flange
681E/387	E-Band	60-90	90°	Left or Right	1.15:1	WR-12 Waveguide, UG-387/U Flange
681W/387	W-Band	75-110	90°	Left or Right	1.15:1	WR-10 Waveguide, UG-387/U Flange
681F/387	F-Band	90-140	90°	Left or Right	1.15:1	WR-8 Waveguide, UG-387/U Flange
681D/387	D-Band	110-170	90°	Left or Right	1.15:1	WR-6 Waveguide, UG-387/U-M Flange
681G/387	G-Band	140-220	90°	Left or Right	1.15:1	WR-5 Waveguide, UG-387/U Flange
681H/387	H-Band	170-260	90°	Left or Right	1.15:1	WR-4 Waveguide, UG-387/U Flange
681J/387	J-Band	220-325	90°	Left or Right	1.15:1	WR-3 Waveguide, UG-387/U Flange

690 Series

Flanged Waveguide Sections

MI-WAVE®

Millimeter Wave Products Inc.

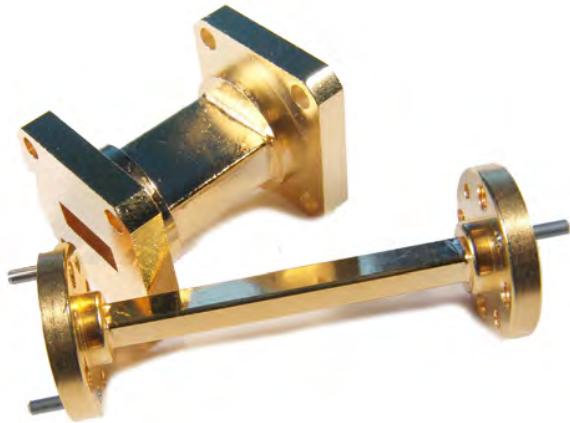

Description

Mi-Wave's 690 Series flanged waveguide sections are available in standard waveguide sizes from 8.2 to 325 GHz. Each section is precisely fabricated using MIL-SPEC waveguide and flanges. Precise control of the fabrication processes eliminates waveguide discontinuities and distortion.

The 690 Series waveguide is available in a wide variety of materials. Available lengths are limited by raw waveguide which varies length with each waveguide size. Check with Mi-Wave's sales engineer for available lengths. Longer sections different wave-guide materials, and special flanges are all available upon request.

Applications

The 690 Series straight waveguide sections with standard flanges are used in operational millimeter wave transmission systems and as basic transmission sections in test and laboratory sets.

Model Number	Band	Frequency (GHz)	VSWR (Typ)	RF Ports
690X/39	Ku-Band	8.2-12.4	1.15:1	WR-90 Waveguide, UG-39/U Flange
690Ku/419	Ku-Band	12.4-18	1.2:1	WR-62 Waveguide, UG-419/U Flange
690K/595	K-Band	18-26.5	1.06:1	WR-42 Waveguide, UG-595/U Flange
690A/599	Ka-Band	26.5-40	1.06:1	WR-28 Waveguide, UG-599/U Flange
690B/383	Q-Band	33-50	1.06:1	WR-22 Waveguide, UG-383/U Flange
690U/383	U-Band	40-60	1.12:1	WR-19 Waveguide, UG-383/U Flange
690V/385	V-Band	50-75	1.15:1	WR-15 Waveguide, UG-385/U Flange
690E/387	E-Band	60-90	1.15:1	WR-12 Waveguide, UG-387/U Flange
690W/387	W-Band	75-110	1.15:1	WR-10 Waveguide, UG-387/U Flange
690F/387	F-Band	90-140	1.15:1	WR-8 Waveguide, UG-387/U Flange
690D/387	D-Band	110-170	1.15:1	WR-6 Waveguide, UG-387/U-M Flange
690G/387	G-Band	140-220	1.15:1	WR-5 Waveguide, UG-387/U Flange
690H/387	H-Band	170-260	1.15:1	WR-4 Waveguide, UG-387/U Flange
690J/387	J-Band	220-325	1.15:1	WR-3 Waveguide, UG-387/U Flange

Ruggedized machine waveguides available in most bands

692 Series

Tapered Transitions

MI-WAVE®

Millimeter Wave Products Inc.

Description

Mi-Wave's 692 Series tapered transitions are precision tapers with standard flanges for two different waveguide sizes. In each transition, the fabrication process allows precise control of taper dimensions to provide a good impedance match. As a result, high mode purity is maintained in the transfer process with minimum VSWR (Typ) effects and energy loss. These transitions are available in many waveguide size combinations from 8.2 to 325 GHz.

- *Low Loss*
- *Minimum Reflections*
- *Precise Fabricated Tapers*
- *Shortest Possible Insertion Length Consistent with High Mode Purity*



In addition to the standard configurations listed in this section, many special transitions will be developed upon request.

Model Number	Band	Frequencies (GHz)	VSWR (Typ)	RF Ports
692X-B/39/383	X-Band Q-Band	8.2-12.4 33-50	1:10:1	WR-90 Waveguide, UG-39/U Flange WR-22 Waveguide, UG-383/U Flange
692X-Ku/39/419	X-Band Ku-Band	8.2-12.4 12.4-18	1:10:1	WR-90 Waveguide, UG-39/U Flange WR-62 Waveguide, UG-419/U Flange
692Ku-K/419/595	Ku-Band K-Band	12.4-18 18-26.5	1:10:1	WR-62 Waveguide, UG-419/U Flange WR-42 Waveguide, UG-595/U Flange
692K-B/595/383	K-Band Q-Band	18-26.5 33-50	1:10:1	WR-42 Waveguide, UG-595/U Flange WR-22 Waveguide, UG-383/U Flange
692K-A/595/599	K-Band Ka-Band	18-26.5 26.5-40	1:10:1	WR-42 Waveguide, UG-595/U Flange WR-28 Waveguide, UG-599/U Flange
692A-H/599/387	Ka-Band H-Band	26.5-40 170-260	1:15:1	WR-28 Waveguide, UG-599/U Flange WR-04 Waveguide, UG-387/U-M Flange
692A-U/599/383	Ka-Band U-Band	26.5-40 40-60	1:10:1	WR-28 Waveguide, UG-599/U Flange WR-19 Waveguide, UG-383/U-M Flange
692A-V/599/385	Ka-Band V-Band	26.5-40 50-75	1:10:1	WR-28 Waveguide, UG-599/U Flange WR-15 Waveguide, UG-385/U Flange
692B-U/383	Q-Band U-Band	33-50 40-60	1:10:1	WR-22 Waveguide, UG-383/U Flange WR-19 Waveguide, UG-383/U-M Flange
692B-V/383/385	Q-Band V-Band	33-50 50-75	1:10:1	WR-22 Waveguide, UG-383/U Flange WR-15 Waveguide, UG-385/U Flange
692U-V/383/385	U-Band V-Band	40-60 50-75	1:10:1	WR-19 Waveguide, UG-383/U-M Flange WR-15 Waveguide, UG-385/U Flange
692V-E/385/387	V-Band E-Band	50-75 60-90	1:10:1	WR-15 Waveguide, UG-385/U Flange WR-12 Waveguide, UG-387/U Flange
692E-W/387	E-Band W-Band	60-90 75-110	1:10:1	WR-12 Waveguide, UG-387/U Flange WR-10 Waveguide, UG-387/U-M Flange
692W-D/387	W-Band D-Band	75-110 110-170	1:15:1	WR-10 Waveguide, UG-387/U-M Flange WR-06 Waveguide, UG-387/U-M Flange
692W-F/387	W-Band F-Band	75-110 90-140	1:12:1	WR-10 Waveguide, UG-387/U-M Flange WR-8 Waveguide, UG-387/U-M Flange
692W-J/387	W-Band J-Band	75-110 220-325	1:15:1	WR-10 Waveguide, UG-387/U-M Flange WR-03 Waveguide, UG-387/U-M Flange
692F-D/387	F-Band D-Band	90-140 110-170	1:15:1	WR-08 Waveguide, UG-387/U Flange WR-06 Waveguide, UG-387/U-M Flange
692D-G/387	D-Band G-Band	110-170 140-220	1:15:1	WR-06 Waveguide, UG-387/U-M Flange WR-05 Waveguide, UG-387/U-M Flange
692G-H/387	G-Band H-Band	140-220 170-260	1:25:1	WR-05 Waveguide, UG-387/U Flange WR-04 Waveguide, UG-387/U-M Flange
692H-J/387	H-Band J-Band	170-260 220-325	1:25:1	WR-04 Waveguide, UG-387/U Flange WR-03 Waveguide, UG-387/U-M Flange
692J-(2.2)/387	J-Band WR-2.2	220-325 330-500	1:25:1	WR-03 Waveguide, UG-387/U Flange WR-2.2 Waveguide, UG-387/U-M Flange

695 Series

Waveguide Stands

MI-WAVE®

Millimeter Wave Products Inc.

Description

MMi-Wave offers 2 types of waveguide stands, adjustable clamp type and criss cross type. 695 model consists of an adjustable clamp mounted on an adjustable height rugged base stand. The unique waveguide clamp may be readily adjusted to fit the clamping jaws to particular waveguide sizes or orientations. The cast stand has a large base area to prevent moving or tipping under normal test bench conditions. For further stability, the base may be secured to the bench with mounting bolts.

- *Rugged configuration*
- *Quick and smooth one knob adjustment*
- *Instrumentation grade*
- *695 model Clamp Rigidly Secures Waveguide, Single Thumbscrew*

695-4, 695-6 and 695-8 models are crisscross type mini jack that provides an adjustable support solution in laboratory environments.

The mini jack is especially helpful when setting up bench top test sets or module testing systems.

Applications

- Lab apparatus support
- Test setup support
- Waveguide system support

695 Adjustable Clamp

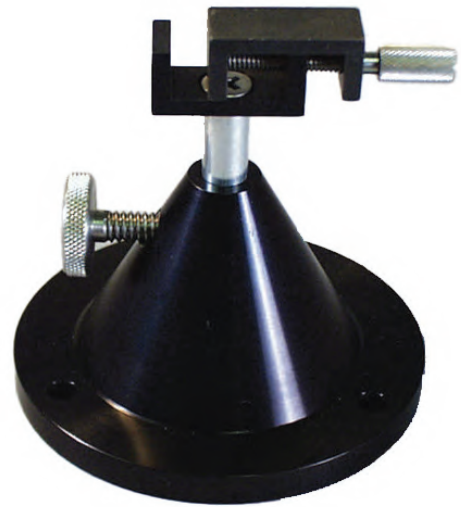

695 Criss-Cross Type



Model Number	Configuration	Base Dimension	Adjustable Height	Weight Capacity
695	Adjustable clamp mounted on adjustable height	3 Inches Diameter	1.19" to 2.01"	
695-4	Criss-Cross Type	4 x 4 Inches (101.6 x 101.6 mm)	1.7" to 7" (43.18 to 177.8 mm)	22 lbs. (10 Kg)
695-6	Criss-Cross Type	6 x 6 Inches (152.4 x 152.4mm)	2.2" to 9.8" (50.8 to 248.9mm)	55 lbs. (25 Kg)
695-8	Criss-Cross Type	8 x 8 Inches (203.2mm x 203.2mm)	2.4" to 12.3" (60mm to 312.42mm)	110 lbs. (50 Kg)

705/707 Series

Pressurizing Units and Pressure Windows

MI-WAVE®
Millimeter Wave Products Inc.

705 Description

Each of Mi-Wave's 705 Series Pressurizing Units consists of a short length of flanged, rectangular waveguide fitted with a Schrader valve and optional pressure gauge. These units are available in all standard wave-guide sizes from 18 to 325 GHz. In A-band, the choke-to-cover flange combination makes allowances for the insertion of a standard O-ring gasket to ensure maintenance of pressurization over operation. Provision is made for gaskets in the case of the round flanges used for millimeter wave frequencies.

- *System Pressure Continuously Monitored*
- *Convenient Means for Pressurizing Waveguide Transmission Lines.*



Applications

The 705 Series Pressurizing Units are designed for applications such as high power radar systems that require a pressurized transmission line to prevent arcing during peak power operation. The pressurizing units can also be used to purge systems with dry gases in order to prevent condensation. These devices provide a simple means for introducing the desired pressurizing gas into the system and for continuous monitoring of internal pressure level.

707 Description

MIWV Series 707 Waveguide pressure windows are used to contain various gasses including pressurized air and SF6. Similarly, pressure windows are also used to prevent any undesirable contaminants (such as moisture) from entering waveguide systems

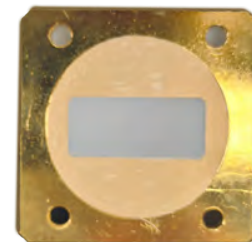

707 Pressure Windows

Model Number	Band	Frequency (GHz)	Insertion Loss (Typ)	VSWR (Typ)	RF Port
707X/39	X-Band	8.2-12.4	0.2	1.10:1	WR-90 Waveguide, UG-39/U Flange
707Ku/419	Ku-Band	12.4-18	0.2	1.10:1	WR-62 Waveguide, UG-419/U Flange
707K/595	K-Band	18-26.5	0.2	1.10:1	WR-42 Waveguide, UG-595/U Flange
707(34)/595	WR34	22-33	0.2	1.10:1	WR-34 Waveguide, UG-595/U Square Flange
707(34)/381	WR34	22-33	0.2	1.10:1	WR-34 Waveguide, UG-381/U Round Flange
707A/599	Ka-Band	26.5-40	0.2	1.10:1	WR-28 Waveguide, UG-599/U Square Flange
707B/383	Q-Band	33-50	0.2	1.10:1	WR-22 Waveguide, UG-383/U Round Flange
707U/383	U-Band	40-60	0.2	1.10:1	WR-19 Waveguide, UG-383/U-M Round Flange
707V/385	V-Band	50-75	0.2	1.10:1	WR-15 Waveguide, UG-385/U Round Flange
707E/387	E-Band	60-90	0.2	1.10:1	WR-12 Waveguide, UG-387/U Round Flange
707W/387	W-Band	75-110	0.3	1.15:1	WR-10 Waveguide, UG-387/U-M Round Flange
707F/387	F-Band	90-140	0.3	1.15:1	WR-08 Waveguide, UG-387/U-M Round Flange
707D/387	D-Band	110-170	0.3	1.15:1	WR-06 Waveguide, UG-387/U-M Round Flange
707G/387	G-Band	140-220	0.35	1.25:1	WR-05 Waveguide, UG-387/U-M Round Flange

712/713/714 Series

Bulkhead Waveguide Adapters, Panel Mounts

MI-WAVE®
Millimeter Wave Products Inc.

712 Series | Waveguide Bulkhead Adapters

Each of Mi-Wave's 712 Series Waveguide Bulkhead adapters was developed for panel feed-thru use in systems. These 712 adapters operate over the full waveguide bands from 8.2 to 325 GHz. O-rings are provided on the panel mount for moisture resistance and a wide variety of flange types and configurations. Units come with a body, two nuts, and two O-rings.

- *Full Waveguide Bandwidths*
- *O-Ring, Provided for Moisture Resistance*
- *Waveguide Feed-thru for Panel Mount Applications*
- *Adjustable*



Standard lengths are 1.00 inches with custom lengths available upon request. Consult MiWave for further details

713 Series | Outside Standard Panel Mounts

Each of Mi-Wave's 713 Series Outside Standard Panel Mounts is used for pannel feed-thru within the system. Consult Mi-Wave for further details. These are connected from outside the box.

- *Full Waveguide Bandwidths*
- *Waveguide Feed-thru for Panel Mount Applications*



714 Series | Inside Standard Panel Mounts

Each of Mi-Wave's 714 Series Inside Standard Panel Mounts is used for pannel feed-thru within the system. Consult MiWave for further details. These are connected from inside of the box.

- *Full Waveguide Bandwidths*
- *Waveguide Feed-thru for Panel Mount Applications*

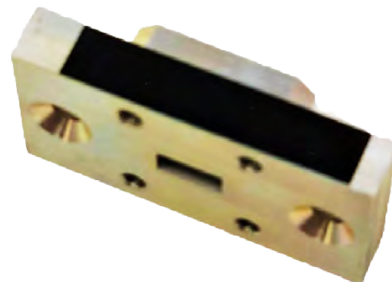

750 Series

Blank Flanges

MI-WAVE®
Millimeter Wave Products Inc.

Choke Flanges

Choke Flanges are offered only in square flanges.

Choke flanges come with O-ring groove and choke cavity.

A choke connection is formed by mating one choke flange and one cover (or gasket/cover) flange.

The central region of the choke flange face is very slightly recessed so that it does not touch the face of the cover flange, but is separated from it by a narrow gap. The recessed region is bounded by a deep choke trench (or ditch or groove) cut into the face of the flange.

Choke flanges are only used with rectangular waveguide, and are invariably pressurizable, having a gasket groove encircling the choke ditch. The presence of these two concentric circular grooves makes choke flanges easily recognizable.

It is considered wrong to join together two choke flanges; the resulting gap between the flange faces is twice that intended, and the effect is similar to that of having two joins in the guide rather than one.



Grooved Flanges

Grooved Flanges have O-ring groove only.

Choke and Grooved flanges are used to prevent any leakage or making air tight seal to prevent the ingress of moisture.

Grooved flanges are mated with cover flanges.

It is considered wrong to join together two choke flanges; the resulting gap between the flange faces is twice that intended, and the effect is similar to that of having two joins in the guide rather than one.

Anti-cocking flange

The anti-cocking flange is used to combat the misalignment known as cocking.

Cocking refers to when two mating surfaces are not touching at all points.

There is a risk of cocking when two flat flanges are connected and the four captive waveguide screws are not tightened equally.

Unevenness or over-torquing can result in gaps or deformation of mating surfaces. To avoid this phenomenon, the anti-cocking flange features a raised outer ring that prevents over tightening and improved parallelism of the mating surfaces.

Model	Frequency Band	Frequency Range	Flange Designation
750X/39	X-Band	8.20 to 12.40 GHz	UG-39/U Square Cover Flange
750Ku/419	Ku-Band	12 to 18 GHz	UG-419/U Square Cover Flange
750K/595	K-Band	18 to 27 GHz	UG-595/U Square Cover Flange
750K/425	K-Band	18 to 27 GHz	UG-425/U Round Cover Flange
750(34)/595	WR-34 Band	22 to 33 GHz	UG-595/U Square Cover Flange
750A/381	Ka-Band	26.5 to 40 GHz	UG-381/U Round Cover Flange
750A/599	Ka-Band	26.5 to 40 GHz	UG-599/U Square Cover Flange
750B/383	Q-Band	33 to 50 GHz	UG-383/U Round Cover Flange
750B/719	Q-Band	33 to 50 GHz	UG-719/U Square Cover Flange
750U/383	U-Band	40 to 60 GHz	UG-383/U-M Round Cover Flange
750U/720	U-Band	40 to 60 GHz	UG-720/U Square Cover Flange
750V/385	V-Band	50 to 65 GHz	UG-385/U-M Round Cover Flange
750E/387	E-Band	60 to 90 GHz	UG-387/U Round Cover Flange
750W/387	W-Band	75 to 110 GHz	UG-387/U-M Round Cover Flange
750F/387	F-Band	90 to 140 GHz	UG-387/U-M Round Cover Flange
750D/387	D-Band	110 to 170 GHz	UG-387/U-M Round Cover Flange
750G/387	G-Band	140–220-GHz	UG-387/U-M Round Cover Flange
750H/387	H-Band	170 – 260 GHz.	UG-387/U-M Round Cover Flange
750J/387	J-Band	220 to 325 GHz	UG-387/U-M Round Cover Flange

752/754/755 Series

Screws and Hardware

MI-WAVE®
Millimeter Wave Products Inc.

Mi-Wav offers the broadest and deepest inventory of RF and microwave components available, which includes RF Flange Pins, Screws and Nuts.

Standard lengths are 1.00 inches with custom lengths available upon request. Consult Mi-Wave for further details



Model Number	Description	Flange Compatibility	Material	Dimensions	Quantity
752	Flange Pins	UG-383 UG-385 UG-387	Stainless Steel	.312 x .0615" (7.92mm x 1.56mm)	100

754



755



Model Number	Description	Flange Compatibility	Material	Threading	Dimensions	Tool Compatibility	Quantity	Notes
754	Captivated Flange Screws	UG-383; UG-385; UG-387	Stainless Steel	4-40 UNRC-3A	5/16" Long (7.94 mm)	03/32 x 1/16" Hex Head Driver	100	Included with associated part orders @ 2x per flange. Refer to part ID "754" to order additional quantity or replacements.
755	Flange Screws	UG-39; UBR-120; UG-419; UBR-180; UG-595; UG-599; UG-719	Stainless Steel	4-40 UNRC-3A	1/2" Long (12.7 mm)	03/32 x 1/16" Hex Head Driver	50	Part includes screws and small-pattern nuts. Not included with associated part orders.

770 Series

Trihedral Reflectors

MI-WAVE®

Millimeter Wave Products Inc.

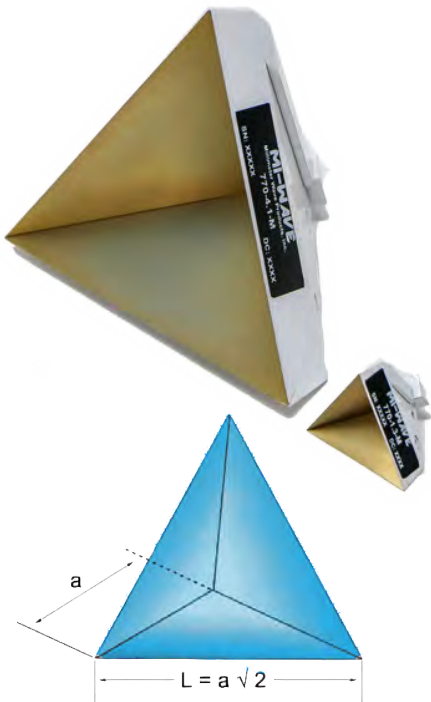

MI-Wave's series 770 Trihedral Reflector are passive devices used to reflect radio waves back toward the emission source directly. Therefore, corner reflector is a useful device for Radar system calibration. In general, the corner reflector consists mutually intersected perpendicular plates

The effective area is calculated by:

$$A_{eff} = \frac{a^2}{\sqrt{3}}$$

Where "a" is the edge length of the trihedral.

- Low Cost
- High Directivity and Gain (Typ)
- Simple Mechanical Performance

The effective radar cross section is calculated by:

$$\sigma = \frac{4\pi a^4}{3\lambda^2}$$

Applications

Radars, Test Chambers, Calibration Systems

Model Number	Frequency (GHz)	Length (a) (inches)	Length (L) (inches)	RCS (dBm)	Mounting Bracket Optional
770-2.8-m	10	2	2.8	-15	Metric thread M3 x 0.5 and 1/4 x 20
770-2.8-m	20	2	2.8	-9	Metric thread M3 x 0.5 and 1/4 x 20
770-2.8-m	30	2	2.8	-5.5	Metric thread M3 x 0.5 and 1/4 x 20
770-2.8-m	40	2	2.8	-3	Metric thread M3 x 0.5 and 1/4 x 20
770-2.8-m	50	2	2.8	-1.1	Metric thread M3 x 0.5 and 1/4 x 20
770-2.8-m	60	2	2.8	0.48	Metric thread M3 x 0.5 and 1/4 x 20
770-2.8-m	70	2	2.8	1.8	Metric thread M3 x 0.5 and 1/4 x 20
770-2.8-m	80	2	2.8	3	Metric thread M3 x 0.5 and 1/4 x 20
770-2.8-m	90	2	2.8	4	Metric thread M3 x 0.5 and 1/4 x 20
770-2.8-m	100	2	2.8	5	Metric thread M3 x 0.5 and 1/4 x 20
770-2.8-m	110	2	2.8	5.7	Metric thread M3 x 0.5 and 1/4 x 20
770-2.8-m	120	2	2.8	6.5	Metric thread M3 x 0.5 and 1/4 x 20
770-4.2-m	10	3	4.2	-8	Metric thread M3 x 0.5 and 1/4 x 20
770-4.2-m	20	3	4.2	-2	Metric thread M3 x 0.5 and 1/4 x 20
770-4.2-m	30	3	4.2	1.5	Metric thread M3 x 0.5 and 1/4 x 20
770-4.2-m	40	3	4.2	4	Metric thread M3 x 0.5 and 1/4 x 20
770-4.2-m	50	3	4.2	6	Metric thread M3 x 0.5 and 1/4 x 20
770-4.2-m	60	3	4.2	7.5	Metric thread M3 x 0.5 and 1/4 x 20
770-4.2-m	70	3	4.2	8.8	Metric thread M3 x 0.5 and 1/4 x 20
770-4.2-m	80	3	4.2	10	Metric thread M3 x 0.5 and 1/4 x 20
770-4.2-m	90	3	4.2	11	Metric thread M3 x 0.5 and 1/4 x 20
770-4.2-m	100	3	4.2	12	Metric thread M3 x 0.5 and 1/4 x 20
770-4.2-m	110	3	4.2	12.8	Metric thread M3 x 0.5 and 1/4 x 20
770-4.2-m	120	3	4.2	13.5	Metric thread M3 x 0.5 and 1/4 x 20

770 Series

Trihedral Antennas

MI-WAVE®

Millimeter Wave Products Inc.

Model Number	Frequency (GHz)	Length (a) (inches)	Length (L) (inches)	RCS (dBm)	Mounting Bracket Optional
770-4.2-m	90	3	4.2	11	Metric thread M3 x 0.5 and 1/4 x 20
770-4.2-m	100	3	4.2	12	Metric thread M3 x 0.5 and 1/4 x 20
770-4.2-m	110	3	4.2	12.8	Metric thread M3 x 0.5 and 1/4 x 20
770-4.2-m	120	3	4.2	13.5	Metric thread M3 x 0.5 and 1/4 x 20
770-5.6-m	10	4	5.6	-3	Metric thread M3 x 0.5 and 1/4 x 20
770-5.6-m	20	4	5.6	3	Metric thread M3 x 0.5 and 1/4 x 20
770-5.6-m	30	4	5.6	6.5	Metric thread M3 x 0.5 and 1/4 x 20
770-5.6-m	40	4	5.6	9	Metric thread M3 x 0.5 and 1/4 x 20
770-5.6-m	50	4	5.6	11	Metric thread M3 x 0.5 and 1/4 x 20
770-5.6-m	60	4	5.6	12.5	Metric thread M3 x 0.5 and 1/4 x 20
770-5.6-m	70	4	5.6	13.8	Metric thread M3 x 0.5 and 1/4 x 20
770-5.6-m	80	4	5.6	15	Metric thread M3 x 0.5 and 1/4 x 20
770-5.6-m	90	4	5.6	16	Metric thread M3 x 0.5 and 1/4 x 20
770-5.6-m	100	4	5.6	17	Metric thread M3 x 0.5 and 1/4 x 20
770-5.6-m	110	4	5.6	17.7	Metric thread M3 x 0.5 and 1/4 x 20
770-5.6-m	120	4	5.6	18.5	Metric thread M3 x 0.5 and 1/4 x 20
770-7-m	10	5	7	0.8	Metric thread M3 x 0.5 and 1/4 x 20
770-7-m	20	5	7	6.8	Metric thread M3 x 0.5 and 1/4 x 20
770-7-m	30	5	7	10.3	Metric thread M3 x 0.5 and 1/4 x 20
770-7-m	40	5	7	12.8	Metric thread M3 x 0.5 and 1/4 x 20
770-7-m	50	5	7	14.8	Metric thread M3 x 0.5 and 1/4 x 20
770-7-m	60	5	7	16.4	Metric thread M3 x 0.5 and 1/4 x 20
770-7-m	70	5	7	17.7	Metric thread M3 x 0.5 and 1/4 x 20
770-7-m	80	5	7	18.8	Metric thread M3 x 0.5 and 1/4 x 20
770-7-m	90	5	7	20	Metric thread M3 x 0.5 and 1/4 x 20
770-7-m	100	5	7	20.8	Metric thread M3 x 0.5 and 1/4 x 20
770-7-m	110	5	7	21.6	Metric thread M3 x 0.5 and 1/4 x 20
770-7-m	120	5	7	22	Metric thread M3 x 0.5 and 1/4 x 20
770-8-m	10	5.6	8	2.8	Metric thread M3 x 0.5 and 1/4 x 20
770-8-m	20	5.6	8	8.8	Metric thread M3 x 0.5 and 1/4 x 20
770-8-m	30	5.6	8	12.3	Metric thread M3 x 0.5 and 1/4 x 20
770-8-m	40	5.6	8	14.8	Metric thread M3 x 0.5 and 1/4 x 20
770-8-m	50	5.6	8	16.7	Metric thread M3 x 0.5 and 1/4 x 20
770-8-m	60	5.6	8	18.3	Metric thread M3 x 0.5 and 1/4 x 20
770-8-m	70	5.6	8	19.7	Metric thread M3 x 0.5 and 1/4 x 20
770-8-m	80	5.6	8	20.8	Metric thread M3 x 0.5 and 1/4 x 20
770-8-m	90	5.6	8	22	Metric thread M3 x 0.5 and 1/4 x 20
770-8-m	100	5.6	8	22.8	Metric thread M3 x 0.5 and 1/4 x 20
770-8-m	110	5.6	8	23.6	Metric thread M3 x 0.5 and 1/4 x 20
770-8-m	120	6	8	24	Metric thread M3 x 0.5 and 1/4 x 20

780 Series

Waveguide Calibration Kits

MI-WAVE®

Millimeter Wave Products Inc.



Description

Mi-Wave's 780 Series Waveguide Calibration Kits are made to precisely calibrate Vector Network Analyzers (VNA) utilizing millimeter waveguide test heads or modules from 18 to 325 GHz. These kits provide the Triple Offset Short (SSST) calibration method utilizing offset shorts and fixed precision termination.

The precision fixed shorts have been selected to provide a high level of return loss (typ) >40 dB and fixed short circuits are optimized to 1/8, 1/4, and 3/8 wavelengths with tight tolerances. These kits are provided with one rugged straight waveguide, 1/8, 1/4, 3/8, and reference short circuits precision fixed to load in a foam-lined wooden case.



Model Number	Band	Minimum Frequency (GHz)	Maximum Frequency (GHz)	VSWR (Typ)	RF Ports
780K/595	K-Band	18	26.5	1:06:01	WR-42 Waveguide UG-595/U Flange
780(34)/595	WR-34	22	33	1:06:01	WR-42 Waveguide UG-595/U Flange
780A/599	Ka-Band	26.5	40	1:06:01	WR-42 Waveguide UG-599/U Flange
780B/383	Q-Band	33	50	1:06:01	WR-22 Waveguide UG-383/U Flange
780U/383	U-Band	40	60	1:06:01	WR-19 Waveguide UG-383/U-M Flange
780V/385	V-Band	50	75	1:06:01	WR-15 Waveguide UG-385/U Flange
780E/387	E-Band	60	90	1:06:01	WR-12 Waveguide UG-387/U Flange
780W/387	W-Band	75	110	1:06:01	WR-10 Waveguide UG-387/U-M Flange
780F/387	F-Band	90	140	1:06:01	WR-8 Waveguide UG-387/U-M Flange
780D/387	D-Band	110	170	1:06:01	WR-6 Waveguide UG-387/U-M Flange
780G/387	G-Band	140	220	1:06:01	WR-5 Waveguide UG-387/U-M Flange
780H/387	H-Band	170	260	1:06:01	WR-4 Waveguide UG-387/U-M Flange
780J/387	J-Band	220	325	1:06:01	WR-3 Waveguide UG-387/U-M Flange

830/840 Series

RF Mechanically Controlled and RF Wide Band Voltage Controlled Oscillators

MI-WAVE®
Millimeter Wave Products Inc.

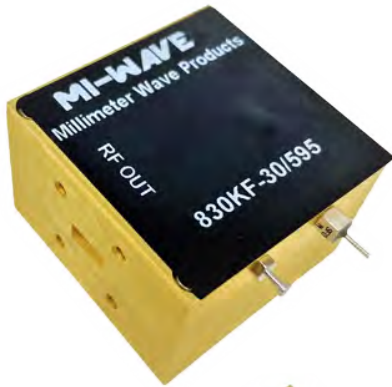

Description

Mi-Wave's 830 Series Fixed Frequency source are available in 18 to 110 GHz frequency range.

This source can be used for a mixer local oscillator or transmit source. The 830 Series is a moderate stability source.

Very high power sources available.

- *Low Noise'*
- *High Stability*
- *18 to 110 GHz*
- *Broadband Tuning*
- *Excellent Reliability*
- *In-Built Regulator*
- *Heatsink Included for high power sources*

Mi-Wave's 840 Voltage controlled sources are available in 18 to 110 GHz. This source can be used as a modulated transmitter or local oscillator. Common applications include radar, swept sources, and telecommunications systems.

Applications

- Radar
- Radiometers
- Local Oscillators
- Telecommunications

***Please contact Mi-Wave for any custom requirements**

Model Number	Band	Frequency (GHz)	Output Power (dBm)	Output Port
830KF-30/595	K-Band	18-26.5	30	WR-42 Waveguide with UG-595/U Flanges
830AF-36/599	Ka-Band	26.5-40	36	WR-28 Waveguide, UG-599/U Flanges
830BF-20/383	Q-Band	33-50	20	WR-22 Waveguide, UG-383/U Flanges
830UF-29/383	U-Band	40-60	29	WR-19 Waveguide, UG-383/U-M Flanges
830VF-25/385	V-Band	50-75	25	WR-15 Waveguide, UG-385/U Flange
830EF-17/387	E-Band	60-90	17	WR-12 Waveguide, UG-387/U Flange
830WF-15/387	W-Band	75-110	15	WR-10 Waveguide, UG-387/U-M Flange

Model Number	Band	Frequency (GHz)	Output Power (dBm)	Output Port
840KF-30/595	K-Band	18-26.5	30	WR-42 Waveguide with UG-595/U Flanges
840AF-36/599	Ka-Band	26.5-40	36	WR-28 Waveguide, UG-599/U Flanges
840BF-20/383	Q-Band	33-50	20	WR-22 Waveguide, UG-383/U Flanges
840UF-29/383	U-Band	40-60	29	WR-19 Waveguide, UG-383/U-M Flanges
840VF-25/385	V-Band	50-75	25	WR-15 Waveguide, UG-385/U Flange
840EF-17/387	E-Band	60-90	17	WR-12 Waveguide, UG-387/U Flange
840WF-15/387	W-Band	75-110	+15	WR-10 Waveguide, UG-387/U-M Flange

870 Series

Noise Sources

MI-WAVE®
Millimeter Wave Products Inc.



Description

Mi-Wave's 870 Series Precision Calibrated Noise Sources are available in 18 to 110 GHz frequency range offering the best stability, switching speed and ripple-free response over other brands.

- *Low Noise'*
- *High Stability*
- *18 to 110 GHz.*
- *Ripple Free*
- *Excellent Reliability*

Mi-Wave's 870 Series have tailored the response so ripple is minimized through the frequency range specified.

Applications

- Noise Figure (Typ) Measurement
- Radar Systems
- Radiometers
- Built In Test Equipment
- Telecommunications
- Military Applications
- 60GHz WiGig
- Small Cell Backhaul

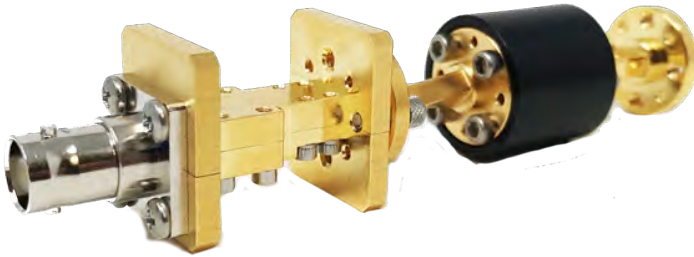

*Noise Source attached with Series 115 Isolator

Model Number	Band	Minimum Frequency (GHz)	Maximum Frequency (GHz)	ENR (dB)	ENR Flatness (dB)	Output Port
870K/595	K-Band	18	26.5	15.5	1.5	WR-42 Waveguide, UG-595/U Flange
870A/599	Ka-Band	26.5	40	15.5	1.5	WR-28 Waveguide, UG-599/U Flanges
870B/383	Q-Band	33	50	15.5	1.5	WR-22 Waveguide, UG-383/U Flanges
870V/385	V-Band	50	75	15.5	3	WR-15 Waveguide, UG-385/U Flange
870E/387	E-Band	60	90	15	6	WR-12 Waveguide, UG-387/U Flange
870W/387	W-Band	75	110	13	5	WR-10 Waveguide, UG-387/U-M Flanges

900 Series

Voltage Controlled Attenuators

MI-WAVE®
Millimeter Wave Products Inc.

Description

Mi-Wave's 900 Series Pin Diode or MMIC Attenuator is a reflective attenuator that combines low loss, High Isolation performance in a compact package. Attenuation options are available for the 900 Series attenuation with Isolation versions up to 60 dB.

- *Series 900 Attenuators 10 to 50 dB narrow or full bandwidth available.*

These attenuators are supplied without drivers, control is typically 0 to +10 Vdc.

Applications

Both series of PIN attenuators can be used for a variety of applications including wave shaping, amplitude modulation, signal switching, and receiver protection.



Model Number	Band	Frequency (GHz)	Insertion Loss (Typ)	Attenuation (dB)	Speed (nS)	Power Handling (dBm)	DC Bias	Control Bias (Volts)	RF Ports
900KF-30/KF	K-Band	18-26.5	3	30	<25	23	+8V to +12V	0 to +10 Volts	K-F
900AF-30/599	Ka-Band	26.5-40	3	30	<25	23	+8V to +12V	0 to +10 Volts	WR-28 Waveguide UG-599/U Flange
900A-60/SMAFTTL-B	Ka-Band	27.5-28.5	3	60	<25	25	+8V to +12V	0 to +10 Volts	SMA-F
900BF-30/383	Q-Band	33-50	3	30	<25	23	+8V to +12V	0 to +10 Volts	WR-22 Waveguide UG-383/U Flange
900UF-30/383	U-Band	40-60	3	30	<25	23	+8V to +12V	0 to +10 Volts	WR-19 Waveguide UG-383/U-M Flange
900VF-30/385	V-Band	50-75	3	30	<25	23	+8V to +12V	0 to +10 Volts	WR-15 Waveguide UG-385/U Flange
900EF-30/387	E-Band	60-90	4	30	<25	23	+8V to +12V	0 to +10 Volts	WR-12 Waveguide UG-387/U Flange
900WF-30/388	W-Band	75-110	4	30	<25	23	+8V to +12V	0 to +10 Volts	WR-10 Waveguide UG-387/U-M Flange

911/912/914 Series

High Speed Pin Diode Switches

MI-WAVE®
Millimeter Wave Products Inc.

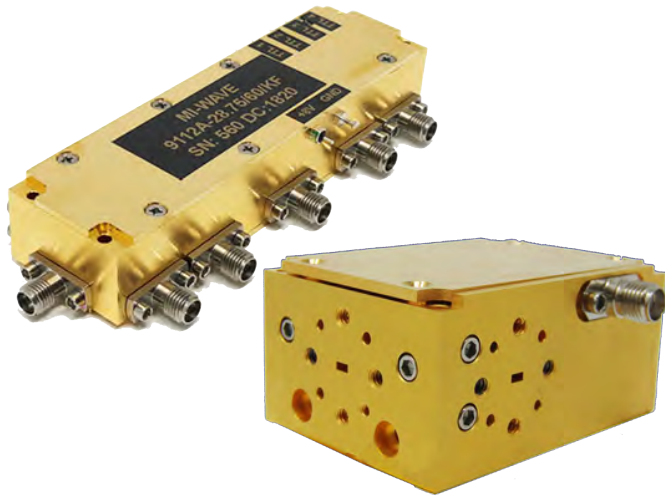

Description

Use MI-Wave's multithrow PIN Switches for a variety of applications that require multiple throws and/or custom switch configuration. These Switches offer Low Insertion Loss and a wide bandwidth of operation for a isolation level. Waveguide and coaxial versions are available depending on the operating frequency. These switches are ideally suited for signal attenuation and switching for receiver protection, antenna switching, test and measurement sets and transreceivers. Switch drivers that accepts TTL signals may be incorporated in these switches as an optional feature.

Applications

PIN switches can be used for a variety of applications including wave shaping, duplexing, pulse modulation, signal switching, and receiver protection.

Other Switch configuration available consult Mi-Wave for applications

Model Number	Band	Type	Frequency (GHz)	Isolation (Typ)	Insertion Loss (Typ)	Max RF Input Power (CW)	Switching Speed (ns)	RF Ports
911AF/599TTL	Ka-Band	SPST	26.5-40	30	3	23	50	WR-28 Waveguide, UG-599/U Flange
911BF/383TTL	Q-Band	SPST	33-50	30	3	23	50	WR-22 Waveguide, UG-383/U Flange
911EF/387TTL	E-Band	SPST	60-90	30	3	23	50	WR-12 Waveguide, UG-387/U Flange
911UF/383TTL	U-Band	SPST	40-60	30	3	23	50	WR-19 Waveguide, UG-383/U-M Flange
911VF/385TTL	V-Band	SPST	50-75	30	3	23	50	WR-15 Waveguide, UG-385/U-M Flange
911WF/387TTL	W-Band	SPST	75-110	30	3	23	50	WR-10 Waveguide, UG-387/U-M Flange
912-20/55/VF	Broad-Band	SPDT	18-50	50	6	23	100	Coaxial - (1.85mm) Female
912-20/55/VF	Broad-Band	SPDT	18-25	50	6	23	100	Coaxial - (1.85mm) Female
912AF/KF	Ka-Band	SPDT	26.5-40	30	3.5	23	50	K-Female Connector
912BF/383TTL	Q-Band	SP2T	33-50	30	4	23	50	WR-22 Waveguide, UG-383/U Flange
912EF/387TTL	E-Band	SPDT	60-90	30	4	23	50	WR-12 Waveguide, UG-387/U-M Flange
912UF/383TTL	U-Band	SPDT	40-60	30	4	23	50	WR-19 Waveguide, UG-383/U-M Flange
912VF/385TTL	V-Band	SPDT	50-75	30	4	23	50	WR-15 Waveguide, UG-385/U-M Flange
912WF-30/387	W-Band	SPDT	75-110	30	4	23	50	WR-10 Waveguide, UG-387/U-M Flange
914-0/40/KF/TTL	Broad-Band	SP4T	DC-40	30	4	23	10	Coaxial - K (2.92mm) Female
914AF-30/383TTL	Ka-Band	SPST	26.5-40	30	6.5	23	30	WR-28 Waveguide, UG-599/U Flange
914BF-30/383TTL	Q-Band	SP4T	33-50	30	6.5	23	30	WR-22 Waveguide, UG-383/U Flange
914EF-30/387TTL	E-Band	SP4T	60-90	30	6.5	23	30	WR-12 Waveguide, UG-387/U-M Flange
914UF-30/383TTL	U-Band	SP4T	40-60	30	6.5	23	30	WR-19 Waveguide, UG-383/U-M Flange
914VF-30/385TTL	V-Band	SP4T	50-75	30	6.5	23	30	WR-15 Waveguide, UG-385/U Flange
914WF-35/387TTL	W-Band	SP4T	75-110	30	6.5	23	30	WR-10 Waveguide, UG-387/U-M Flange
914VF-30/385TTL	V-Band	SP4T	50-75	30	6.5	23	30	WR-15 Waveguide, UG-385/U Flange
914WF-35/387TTL	W-Band	SP4T	75-110	30	6.5	23	30	WR-10 Waveguide, UG-387/U-M Flange
918EF-50/1mmF	E-Band	SP8T	60-90	50	11	23	50	Coaxial - 1.00 mm Female
9112A-28.75/60/KF	Ka-Band	SP12T	26.5-40	60	7	23	50	WR-28 Waveguide, UG-599/U Flange

920/922 Series

Harmonic Mixers

MI-WAVE®

Millimeter Wave Products Inc.

Description

Mi-Wave's 920 Series Harmonic Mixers are used to downconvert millimeter wave signals using a Schottky barrier mixer diode. Measurements can be made by mixing the harmonic of the LO with the desired RF signal and observing the resulting IF.

- *Full Band Coverage*
- *Extends the Useful Frequency Range of Spectrum Analyzers*

The 920 Series is designed for applications where a Diplexer is not required

922 Series include an optional LO-IF frequency diplexer.

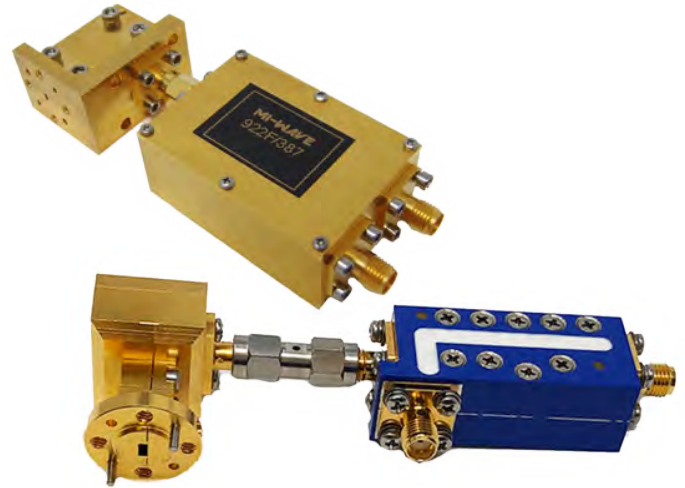

Model Number	Band	Frequency (GHz)	LO Frequency (GHz)	IF Frequency (GHz)	LO Power (dBm)	LO Plus RF Power	RF Port	LO/IF Port
920A/599	Ka-Band	26.5 - 40	Up to 20	Dependent on Diplexer Configuration	13+	13+	WR-28 Waveguide, UG-599/U Flange	SMA (F)
920B-383	Q-Band	33 - 50	Up to 20	Dependent on Diplexer Configuration	13+	13+	WR-22 Waveguide, UG-383/U Flange	SMA (F)
920U-383	U-Band	40 - 60	Up to 20	Dependent on Diplexer Configuration	13+	13+	WR-19 Waveguide, UG-383/U-M Flange	SMA (F)
920V-385	V-Band	50 - 75	Up to 20	Dependent on Diplexer Configuration	13+	13+	WR-15 Waveguide, UG-385/U Flange	SMA (F)
920E-387	E-Band	60 - 90	Up to 20	Dependent on Diplexer Configuration	13+	13+	WR-12 Waveguide, UG-387/U-M Flange	SMA (F)
920W-387	W-Band	75 - 110	Up to 20	Dependent on Diplexer Configuration	13+	13+	WR-10 Waveguide, UG-387/U-M Flange	SMA (F)
920F-387	F-Band	90 - 140	Up to 20	Dependent on Diplexer Configuration	13+	13+	WR-08 Waveguide, UG-387/U-M Flange	SMA (F)
920D-387	D-Band	110 - 170	Up to 20	Dependent on Diplexer Configuration	13+	13+	WR-06 Waveguide, UG-387/U-M Flange	SMA (F)
920G-387	G-Band	140 - 220	Up to 20	Dependent on Diplexer Configuration	13+	13+	WR-05 Waveguide, UG-387/U-M Flange	SMA (F)

Model Number	Band	Frequency (GHz)	LO Frequency (GHz)	IF Frequency (GHz)	LO Power (dBm)	LO Plus RF Power	RF Port	LO/IF Port
922A/387	Ka-Band	26.5 - 40	Option 1: 4-20 Option 2: 6-20	Option 1: DC-3 Option 2: DC-5	13+	13+	WR-28 Waveguide, UG-599/U Flange	SMA (F)
922B/383	Q-Band	33 - 50	Option 1: 4-20 Option 2: 6-20	Option 1: DC-3 Option 2: DC-5	13+	13+	WR-22 Waveguide, UG-383/U Flange	SMA (F)
922U/383	U-Band	40 - 60	Option 1: 4-20 Option 2: 6-20	Option 1: DC-3 Option 2: DC-5	13+	13+	WR-19 Waveguide, UG-383/U-M Flange	SMA (F)
922V/385	V-Band	50 - 75	Option 1: 4-20 Option 2: 6-20	Option 1: DC-3 Option 2: DC-5	13+	13+	WR-15 Waveguide, UG-385/U Flange	SMA (F)
922E/387	E-Band	60 - 90	Option 1: 4-20 Option 2: 6-20	Option 1: DC-3 Option 2: DC-5	13+	13+	WR-12 Waveguide, UG-387/U-M Flange	SMA (F)
922W/387	W-Band	75 - 110	Option 1: 4-20 Option 2: 6-20	Option 1: DC-3 Option 2: DC-5	13+	13+	WR-10 Waveguide, UG-387/U-M Flange	SMA (F)
922F/387	F-Band	90 - 140	Option 1: 4-20 Option 2: 6-20	Option 1: DC-3 Option 2: DC-5	13+	13+	WR-08 Waveguide, UG-387/U-M Flange	SMA (F)
922D/387	D-Band	110 - 170	Option 1: 4-20 Option 2: 6-20	Option 1: DC-3 Option 2: DC-5	13+	13+	WR-06 Waveguide, UG-387/U-M Flange	SMA (F)
922G/387	G-Band	140 - 220	Option 1: 4-20 Option 2: 6-20	Option 1: DC-3 Option 2: DC-5	13+	13+	WR-05 Waveguide, UG-387/U-M Flange	SMA (F)

93(x) Series

Multipliers

MI-WAVE®
Millimeter Wave Products Inc.

Description

Mi-Wave's 93(x) Series Active Multipliers utilize high performance MMIC chips for frequency multiplication and amplification. The multipliers offer moderate conversion Gain (Typ) with output frequency covering 10 to 110 GHz in six Bands. The X2, X3, X4, and X6 are offered as standard multiplication factors. The input power requirement for these multipliers is +5 to +10 dBm. While SMA or K Female coaxial Connector is equipped for input and waveguide for output interface, waveguide input is available as an option for U, V, E, and W Band multipliers.

- High Output Power
- Up to Full Waveguide Operation
- Moderate Conversion Gain (Typ)
- Frequency up to 110



Applications

- Frequency Extenders
- Local Oscillators
- Test Set
- Sub-systems

Model Number	Input Frequency (GHz)	Output Frequency (GHz)	X Factor	Input Power (dBm)	Output Power (dBm)	DC Bias	Input Port	Output Port
932-10/20/10/SMAF-2	5-10	10-20	2	+11 to 16 nominal, +17 max.	+7 to +10 nominal	+8V@105mA, +12V max.	SMA-Female	SMA-Female
932KF-10/KF	9-13.25	18-26.5	2	+5 nominal, +10 max	+15 nominal	+8 V@82 mA, +15 V max.	K-Female	K-Female
932KF-30/3.5mmF	9-13.25	18-26.5	2	+3 to +5 nominal, +10 max.	+31 nominal	+6V@1.35A, +12 V max.	3.5 mm Female	3.5 mm Female
932AF-20/599/KF	13.25-20	26.5-40	2	0 to +5 nominal, +10 max.	20 nominal	+8 V@470mA, +15 V max.	K-Female	WR-28 waveguide, UG-599/U Flange
934BF-10/383	8.25-12.5	33-50	4	+2 nominal, +5 max.	+10 nominal	+8V@0.250 A, +12V max.	K-Female/ SMA- Female	WR-22 waveguide, UG-383/U Flange
934BF-13/383	8.25-12.5	33-50	4	0 to +2 nominal, +5 max.	+14.5 nominal	+8V@0.280 A, +12V max.	K-Female/ SMA- Female	WR-22 waveguide, UG-383/U Flange
934UF-10/383	10-15	40-60	4	0 nominal, +10max.	+13 nominal	+6V@143mA, +6V max.	K-Female/ SMA- Female	WR-19 waveguide, UG-383/U-M Flange
934VF-10/385	12.5-18.75	50-75	4	+5 nominal, +10 max.	+11 nominal	+8V@270mA, +15V max.	K-Female/ SMA- Female	WR-15 waveguide, UG-385/U Flange
934VF-15/385	12.5-18.75	50-75	4	+5 nominal, +10 max.	+15 nominal	+10V@321mA, +15V max.	K-Female/ SMA- Female	WR-15 waveguide, UG-385/U Flange
934EF-20/387	15-22.5	60-90	4	+5 to +7 nominal, +12 max.	+20 nominal	+6 to +8V@650mA, +12V max.	K-Female/ SMA- Female	WR-12 waveguide, UG-387/U Flange
936EF-10/387	10-15	60-90	6	+4 nominal, +10 max.	+13 nominal	+6V@237mA, +12V max.	K-Female/ SMA- Female	WR-12 waveguide, UG-387/U Flange
936EF-20/387H	10-15	60-90	6	+5 nominal, +10 max.	+20 nominal	+6V@540mA, +12V max.	K-Female/ SMA- Female	WR-12 waveguide, UG-387/U Flange
938EF-16/387H	7.5-11.25	60-90	8	+3 to +5 nominal, +10 max.	+17 nominal	+8V@590mA, +12V max.	K-Female/ SMA- Female	WR-12 waveguide, UG-387/U Flange
936WF-10/387	12.5-18.33	75-110	6	+6 nominal, +10 max.	+10 nominal	+6V@309mA, +12V max.	K-Female/ SMA- Female	WR-10 waveguide, UG-387/U-M Flange
936WF-15/387	12.5-18.33	75-110	6	+5 to+10 nominal, +15 max.	+16 nominal	+12V@500mA, +15V max.	K-Female/ SMA- Female	WR-10 waveguide, UG-387/U-M Flange
936WF-20/387	12.5-18.33	75-110	6	+5 to+10 nominal, +15 max.	+20 nominal	+13V@410mA, +15V max.	K-Female/ SMA- Female	WR-10 waveguide, UG-387/U-M Flange
938WF-10/387	10-13.25	75-100	8	+7 nominal, +10 max.	+15 nominal	+6V@180mA, +12V max.	K-Female/ SMA- Female	WR-10 waveguide, UG-387/U-M Flange
938W-80/106/15/388	8.9-11.78	80-106	9	+7 nominal, +10 max.	+15 nominal	+13V@180mA, +15V max.	K-Female/ SMA- Female	WR-10 waveguide, UG-387/U-M Flange

***Please call for custom requirements**

950 Series

Finline Detectors

MI-WAVE®
Millimeter Wave Products Inc.

Description

Mi-Wave's 950 Series Detectors convert incident RF energy into a DC voltage signal. The function of these detectors is similar to power sensors, with two exceptions. The 950 Series detectors perform measurements more quickly and have a greater dynamic range than that obtainable from comparable power sensors.

- *Full Band*
- *High Video Sensitivity*
- *No Bias Voltage Required*
- *Lightweight Compact Design*

Ideally suited for rapid power measurements, these finline detectors are designed for a variety of instrumentation setups such as scalar analyzer applications. For low signal level measurement, the detectors provide significantly more sensitivity than that available from power sensors.



Model Number	Band	Frequency (GHz)	Sensitivity Flatness (±dB)	Input Power (dBm)	Output Voltage Polarity	Specification Temperature (C)	RF Port
950A/599	Ka-Band	26.5-40	2	17	Positive	25	WR-28 Waveguide, UG-599 Flange
950B/383	Q-Band	33-50	2	17	Positive	25	WR-22 Waveguide, UG-383 Flange
950U/383	U-Band	40-60	2	17	Positive	25	WR-19 Waveguide, UG-383 Flange
950V/385	V-Band	50-75	2	17	Positive	25	WR-15 Waveguide, UG-385/U Flange
950E/387	E-Band	60-90	2	20	Positive	25	WR-12 Waveguide, UG-387/U-M Flange
950W/387	W-Band	75-110	2	17	Positive	25	WR-10 Waveguide, UG-387/U-M Flange
950F/387	F-Band	90-140	2.5	17	Positive	25	WR-08 Waveguide, UG-387/U-M Flange
950D/387	D-Band	110-170	3.0	17	Positive	25	WR-06 Waveguide, UG-387/U-M Flange

955 Series

High Power Amplifiers

MI-WAVE®

Millimeter Wave Products Inc.



Description

Mi-Wave's 955 Series microwave and millimeter wave amplifiers offer a wide variety of frequency ranges, bandwidths, Gain and power outputs.

Lost cost production designs to meet the demanding needs of communications are also now available.

Please consult Mi-Wave for technical specifications and outline drawings.

- *High Gain (Typ)*
- *Full Bandwidths*
- *High 1 dB Comp. Points*
- *Wide Variety of Frequency Ranges*
- *18 to 110 GHz*

Model Number	Band	Frequency (GHz)	Gain (Typ)	Output Power P1dB (Typ)	Output Power Psat (Typ)	DC Bias	Input/Output Port
955-18/40/25/24/KF	CrossBand	18-40	25 dB	20 dBm	24 dBm	+12V	2.92mm Female (K)
955A-24/30/40/45/KFH	Ka-Band	24-30	40 dB		45 dBm	+28V	2.92mm K Female Coaxial Connector
955AF-22/27/KFH	Ka-Band	26.5-40	22 dB	27 dBm	28 dBm	+12-15V	2.92mm K Female Coaxial Connector
955AF-30/18/599H	Ka-Band	26.5-40	30 dB		18 dBm	+8V	WR-28 waveguide, UG-599/U Flange
955AF-30/31/599H	Ka-Band	26.5-40	30 dB		31 dBm	+12-+15V	WR-28 waveguide, UG-599/U Flange
955AF-40/36/599H	Ka-Band	26.5-40	40 dB		36 dBm	+6V	WR-28 waveguide, UG-599/U Flange
955A-27/35/43/599	Ka-Band	26-28	35 dB		43 dBm	+20-25V	WR-28 Waveguide, UG-599/ K Female
955A-28/29/30/36/KFH	Ka-Band	28-29	40 dB	32 dBm	36 dBm	+21-24V	WR-28 Waveguide, UG-599/U Flange
955A-29.3/40/41.5/KF/599HAC	Ka-Band	29.3	40 dB		41.5 dBm	*100 ~ 120V "	WR-28,UG-599/K Female
955A-33/36.5/38/42.5/599	Ka-Band	32-36	45 dB		42.5 dBm	+30V	WR-28 waveguide, UG-599/U Flange
955A-32/38/38/42.5/599	Ka-Band	32-38	38 dB		42.5 dBm	+30V	WR-28 waveguide, UG-599/U Flange
955A-33/37/38/40/KFH	Ka-Band	33-37	38 dB		40 dBm	+30V	2.92mm K Female Coaxial Connector
955BF-30/20/383H	B-Band	33-50	30 dB		20 dBm	+8V	WR-22 waveguide, UG-383/U Flange
955B-35/48/30/27/383H	B-Band	35-48	30 dB	25 dBm	27 dBm	+8V	WR-22 waveguide, UG-383/U Flange
955A-37/44/40/43/KFH	Ka-Band	37-44	40 dB		43 dBm	+28V	2.92mm K Female Coaxial Connector
955A-37/44/40/45/KFH	Ka-Band	37-44	40 dB		45 dBm	+28V	2.92mm K Female Coaxial Connector
955B-37/48.2/30/27/1.85mmFH	B-Band	37-48.2	30 dB	27 dBm	dBm	+6V	1.85mm Female Coaxial Connector
955U-44.1/35/33/383	U-Band	40-48.2	35 dB	30 dBm	33 dBm	+6V	WR-19 Waveguide, UG-383/U-M Flange
955UF-25/29/1.85mmF	U-Band	40-60	25 dB		29 dBm	+8-+12V	1.85mm Female Coaxial Connector
955UF-35/22/383	U-Band	40-60	35 dB		22 dBm	+8V	WR-19 Waveguide, UG-383/U-M Flange
955B-43/46/30/33/2.4mmFH	B-Band	43-46	30 dB		33 dBm	+8V	2.4mm Female Coaxial Connector
955U-47.2/48.2/35/39/383	U-Band	47.2-48.2	35 dB	37 dBm	39 dBm	+28V	WR-19 Waveguide, UG-383/U-M Flange
955U-47/52.4/40/37/383	U-Band	47-52.4	40 dB		37 dBm	+28V	WR-19 Waveguide, UG-383/U-M Flange
955U-47/52.4/40/40/383	U-Band	47-52.4	40 dB		40 dBm	+28V	WR-19 Waveguide, UG-383/U-M Flange
955B-50/25/27/2.4mmFH	B-Band	49.5-50.5	25 dB	27 dBm	30 dBm	+6V	2.4mm Female Coaxial Connector
955B-50/40/44/383H	B-Band	49.5-50.5	40 dB	44 dBm	47 dBm	+28V	WR-22 Waveguide with UG-383/U Flanges
955V-50/25/20/2.4mmF	V-Band	49.5-50.5	25 dB	20 dBm	23 dBm	+6V	2.4mm Female Coaxial Connector
955U-49/51/40/45/383H	U-Band	49-51	40 dB	41 dBm	45 dBm	+28V	WR-19 Waveguide, UG-383/U-M Flange
955U-49/51/45/47/383H	U-Band	49-51	45 dB	43 dBm	47 dBm	+28V	WR-19 Waveguide, UG-383/U-M Flange

955 Series

High Power Amplifiers

MI-WAVE®

Millimeter Wave Products Inc.

Model Number	Band	Frequency (GHz)	Gain (Typ)	Output Power P1dB (Typ)	Output Power Psat (Typ)	DC Bias	Input/Output Port
955U-50/66/22/15/383	U-Band	50-66	22 dB		15 dBm	+8V	WR-19 Waveguide, UG-383/U-M Flange
955U-50/67/20/20/1.85mmF	U-Band	50-67	20 dB	20 dBm		+6V	1.85mm Female Coaxial Connector
955V-50/68/35/18/385	V-Band	50-68	35 dB		18 dBm	+6V	WR-15 waveguide, UG-385/U Flange
955V-50/70/28/15/385	V-Band	50-70	28 dB		15 dBm	+6V	WR-15 waveguide, UG-385/U Flange
955VF-25/25/385H	V-Band	50-75	25 dB		25 dBm	+6V	WR-15 waveguide, UG-385/U Flange
955VF-35/15/385	V-Band	50-75	35 dB		15 dBm	+6V	WR-15 waveguide, UG-385/U Flange
955VF-40/385	V-Band	50-75	40 dB	9 dBm	12 dBm	+6V	WR-15 waveguide, UG-385/U Flange
955V-55/65/30/24/385	V-Band	55-65	30 dB	22 dBm	24 dBm	+6V	WR-15 waveguide, UG-385/U Flange
955V-57/68/25/26/385	V-Band	57-68	25 dB	26 dBm		+6V	WR-15 waveguide, UG-385/U Flange
955V-57/70/25/30/385H	V-Band	57-70	25 dB		30 dBm	+8V	WR-15 waveguide, UG-385/U Flange
955V-60/25/31.5/385H	V-Band	59-61	25 dB		31.5 dBm	+6V	WR-15 waveguide, UG-385/U Flange
955EF-25/15/387	E-Band	60-90	25 dB		15 dBm	+8V	WR-12 waveguide, UG-387/U Flange
955EF-25-15-387	E-Band	60-90	30 dB		15 dBm	+6V -12V MAX	WR-12 waveguide, UG-387/U Flange
955EF-30/15/387	E-Band	60-90	30 dB		15 dBm	+8V -12V MAX	WR-12 waveguide, UG-387/U Flange
955E-67.5/35/30/387H	E-Band	65-70	35 dB	27 dBm	30 dBm	+6V	WR-12 waveguide, UG-387/U Flange
955E-70/95/20/16/387	E-Band	70-95	20 dB	15 dBm	16 dBm	+6V	WR-12 waveguide, UG-387/U Flange
955E-71/76/25/30/387	E-Band	71-76	25 dB		30 dBm	+6V	WR-12 waveguide, UG-387/U Flange
955E-71/76/30/32.5/387	E-Band	71-76	30 dB	30.5 dBm	32.5 dBm	+5V	WR-12 waveguide, UG-387/U Flange
955WF-35/15/387H	W-Band	75-110	35 dB	10 dBm	15 dBm	+6V	WR-10 Waveguide, UG-387/U-M Flange
955E-76/81/30/29/387	E-Band	76-81	30 dB	26 dBm	29 dBm	+12V	WR-12 waveguide, UG-387/U Flange
955E-81/86/25/30/387	E-Band	81-86	25 dB		30 dBm	+6V	WR-12 waveguide, UG-387/U Flange
955E-81/86/30/32.5/387	E-Band	81-86	30 dB	30.5 dBm	32.5 dBm	+5V	WR-12 waveguide, UG-387/U Flange
955E-81/86/35/30/387	E-Band	81-86	35 dB		30 dBm	+13 - +14V	WR-12 waveguide, UG-387/U Flange
955W-89/97/25/24/387H	W-Band	89-97	25 dB	24 dBm	27 dBm	+12-+15V	WR-10 Waveguide, UG-387/U-M Flange
955W-92/96/20/28/387	W-Band	92-96	20 dB		28 dBm	+6V	WR-10 Waveguide, UG-387/U-M Flange
955W-92/96/25/30/387	W-Band	92-96	25 dB	27.5 dBm	30 dBm	+6V	WR-10 Waveguide, UG-387/U-M Flange
955W-94/15/387	W-Band	92-96	12 dB		32.5 dBm	+6V	WR-10 Waveguide, UG-387/U-M Flange
955W-94/20/32.5/387	W-Band	92-96	20 dB		32.5 dBm	+6V	WR-10 Waveguide, UG-387/U-M Flange
955W-94/25/27/387	W-Band	92-96	25 dB	27 dBm		+6V	WR-10 Waveguide, UG-387/U-M Flange
955W-94/30/26/387	W-Band	92-96	30 dB	26 dBm	28 dBm	+6V	WR-10 Waveguide, UG-387/U-M Flange
955W-94/30/30/387H	W-Band	92-96	30 dB		30 dBm	+6V	WR-10 Waveguide, UG-387/U-M Flange
955W-94/30/37/387	W-Band	92-96	30 dB		37 dBm	+6V	WR-10 Waveguide, UG-387/U-M Flange
955W-94/35/33/387	W-Band	92-96	35 dB		33 dBm	+6 - +7 V	WR-10 Waveguide, UG-387/U-M Flange
955W-94/35/35/387	W-Band	92-96	35 dB		35 dBm	+13 - +14V	WR-10 Waveguide, UG-387/U-M Flange
955W-93/95/20/30/387	W-Band	93-95	20 dB		30 dBm	+6-+12V	WR-10 Waveguide, UG-387/U-M Flange

955 Series

Low Noise Amplifiers

MI-WAVE®

Millimeter Wave Products Inc.



Description

Mi-Wave's 955 Series microwave and millimeter wave amplifiers offer a wide variety of frequency ranges, bandwidths, Gain and power outputs.

Lost cost production designs to meet the demanding needs of communications are also now available.

Please consult Mi-Wave for technical specifications and outline drawings.

- High Gain (Typ)
- Full Bandwidths
- High 1 dB Comp. Points
- Wide Variety of Frequency Ranges
- 1 to 110 GHz

Model Number	Band	Frequency (GHz)	Gain (Typ)	Noise Figure (Typ)	Output Power Psat (Typ)	Output Power P1dB (Typ)	DC Bias	Input/Output Port
955-01/60/30/1.85mmF	DC - 60GHz	1-60	30 dB	5 dB	12 dBm	10 dBm	+8V	1.85 mm Female Coaxial Connector
955AF-20/599	Ka-Band	26.5-40	20 dB	3.5 dB				WR-28 waveguide, UG-599/U Flange
955AF-20/10/KF	Ka-Band	26.5-40	20 dB	3 dB		10 dBm	+8V	2.92mm K Female Coaxial Connector
955AF-30/18/599H	Ka-Band	26.5-40	30 dB	3 dB	18 dBm		+8V	WR-28 waveguide, UG-599/U Flange
955AF-40/10/2.4mmF	Ka-Band	26.5-40	40 dB	4.5 dB		10 dBm	+8V	2.4mm Female Coaxial Connector
955BF-15/8/383	Q-Band	33-50	10-15 dB	5.5 dB		8 dBm	+8-12V	WR-22 Waveguide, UG-383/U Flanges
955BF-20/10/383	Q-Band	33-50	20 dB	5.5 dB		10 dBm	+8V	WR-22 Waveguide, UG-383/U Flanges
955BF-30/10/383	Q-Band	33-50	30 dB	5.5 dB		10 dBm	+8V	WR-22 Waveguide, UG-383/U Flanges
955BF-40/10/383	Q-Band	33-50	40 dB	6 dB		10 dBm	+8V	WR-22 Waveguide, UG-383/U Flanges
955UF-15/10/383	U-Band	40-60	15 dB	5 dB		10 dBm	+12-15V	WR-19 Waveguide, UG-383/U-M Flange
955UF-20/10/383	U-Band	40-60	20 dB	5 dB		10 dBm	+8V	WR-19 Waveguide, UG-383/U-M Flange
955UF-30/15/383	U-Band	40-60	30 dB	4.5 dB		15 dBm	+6V	WR-19 Waveguide, UG-383/U-M Flange
955UF-30/383	U-Band	40-60	30 dB	5 dB		15 dBm	+6V	WR-19 Waveguide, UG-383/U-M Flange
955UF-40/13/383	U-Band	40-60	40 dB	5 dB	13 dBm		+6V	WR-19 Waveguide, UG-383/U-M Flange
955U-50/66/22/15/383	U-Band	50-66	22 dB	5 dB	22 dBm		+6V	WR-19 Waveguide, UG-383/U-M Flange
955V-50/68/35/18/385	V-Band	50-68	35 dB		18 dBm		+6V	WR-15 Waveguide, UG-385/U Flange
955VF-35/15/385	V-Band	50-75	35 dB		18 dBm		+6V	WR-15 Waveguide, UG-385/U Flange
955VF-35/13/1.85mmF	V-Band	50-75	35 dB	5 dB	13 dBm		+6V	1.85mm Female Coaxial Connector
955VF-20/15/385	V-Band	50-75	20 dB	5 dB	15 dBm		+6V	WR-15 Waveguide, UG-385/U Flange
955VF-30/10/385	V-Band	50-75	30 dB	5 dB	10 dBm		+6V	WR-15 Waveguide, UG-385/U Flange
955VF-40/385	V-Band	50-75	40 dB	5 dB		9 dBm	+6-+8V	WR-15 Waveguide, UG-385/U Flange
955EF-15/8/387	E-Band	60-90	15 dB	4.5 dB		8 dBm	+8V	WR-12 Waveguide, UG-387/U Flange
955EF-20/10/387	E-Band	60-90	20 dB	5.5 dB	10 dBm		+8V	WR-12 Waveguide, UG-387/U Flange
955EF-20/12/387	E-Band	60-90	20 dB	5 dB	12 dBm		+8V	WR-12 Waveguide, UG-387/U Flange
955EF-25/8/387	E-Band	60-90	25 dB	4.5 dB		8 dBm	+8V	WR-12 Waveguide, UG-387/U Flange
955EF-30/8/387	E-Band	60-90	30 dB	4.5 dB		8 dBm	+8V	WR-12 Waveguide, UG-387/U Flange
955E-77/30/387	E-Band	72-82	30 dB	4 dB	14 dBm	8 dBm	+8V	WR-12 Waveguide, UG-387/U Flange
955WF-10/10/387	W-Band	75-110	10 dB	5.5 dB	10 dBm		+8V	WR-10 Waveguide, UG-387/U-M Flanges
955WF-20/10/387	W-Band	75-110	20 dB	5.5 dB	10 dBm		+8V	WR-10 Waveguide, UG-387/U-M Flanges
955WF-20/11.5/387H	W-Band	75-110	20 dB	12 dB	10 dBm		+8V	WR-10 Waveguide, UG-387/U-M Flanges
955WF-25/10/387	W-Band	75-110	25 dB	5.5 dB	10 dBm		+8V	WR-10 Waveguide, UG-387/U-M Flanges
955WF-30/387	W-Band	75-110	30 dB	3 dB	10 dBm		+8V	WR-10 Waveguide, UG-387/U-M Flanges
955WF-35/10/387	W-Band	75-110	35 dB	5 dB	10 dBm		+8V	WR-10 Waveguide, UG-387/U-M Flanges

957 Series

Phase Locked Oscillators

MI-WAVE®

Millimeter Wave Products Inc.



Description

Mi-Wave's 957 Series Phase Locked Oscillators uses fixed frequency low noise synthesizer technology. These oscillators use an external reference from 1MHz to 600MHz and frequency outputs from 100MHz to 110GHz.

Both coaxial and waveguide versions available. Internal crystal references are available on request.

- *Features*
- *TTL Phase Lock Indicator Alarm*
- *Phase Lock Indicator L.E.D.*
- *Low Phase Noise*
- *Compact Design*
- *High Power Versions*

Open loop phase noise offset @ 16GHz

- 80 dBc @ 10Hz
- 100 dBc 100KHz
- 130 dBc @ 1MHz
- 150 dBc @ 10MHz

Waveguide /Coax Versions

Model	Band	Frequency (GHz)	Configuration	Power Output	Port
957X/39	X-Band	8.2-12.4	Waveguide	30 dBm	WR-90 Waveguide UG-39/U Flange
957Ku/419	Ku-Band	12.4-18.0	Waveguide	30 dBm	WR-62 Waveguide UG-419/U Flange
957K/595	K-Band	18-26.5	Waveguide	30 dBm	WR-42 Waveguide UG-595/U Flange
957A/381	Ka-Band	26.5-40	Waveguide	30 dBm	WR-28 Waveguide UG-599/U Flange
957B/383	Q-Band	33-50	Waveguide	30 dBm	WR-22 Waveguide UG-383/U Flange
957U/383	U-Band	40-60	Waveguide	30 dBm	WR-19 Waveguide UG-383/U-M Flange
957V/385	V-Band	50-75	Waveguide	30 dBm	WR-15 Waveguide UG-385/U Flange
957E/387	E-Band	60-90	Waveguide	30 dBm	WR-12 Waveguide UG-387/U Flange
957W/387	W-Band	75-110	Waveguide	30 dBm	WR-10 Waveguide UG-387/U-M Flange

Model	Band	Frequency (GHz)	Configuration	Power Output	Port
957/SMAF	Crossband	100MHz-18GHz	Coaxial	30 dBm	SMA Female
957K/SMA/KF	K-Band	18-26.5	Coaxial	30 dBm	SMA Female II K-Female
957A/KF	Ka-Band	26.5-40	Coaxial	30 dBm	K-Female
957B/1.85mmF	Q-Band	33-50	Coaxial	30 dBm	1.85 mm Female
957U/1.85mmF	U-Band	40-60	Coaxial	30 dBm	1.85 mm Female
957V/1.00mmF	V-Band	50-75	Coaxial	30 dBm	1.00 mm Female
957E/1.00mmF	E-Band	60-90	Coaxial	30 dBm	1.00 mm Female
957W/1.00mmF	W-Band	75-110	Coaxial	30 dBm	1.00 mm Female

970/980, 971 Series

Wide-band Balanced and I/Q Mixers

MI-WAVE®
Millimeter Wave Products Inc.

Description

Mi-Wave's 970/980 Series balanced mixers have been designed to cover extremely wide RF bandwidths for EW/ELINT applications. These units offer excellent SSB conversion loss figures and are available up to 110 GHz. GaAs beam-lead diodes are used with a Broadband circuit to provide excellent IF response. The 970/980 series mixers are available with low noise IF amplifiers.

- *Very Wide RF Bandwidth*
- *Available With or Without IF Amplifiers*

The 970 series is used as a downconverter and the 980 series is used as an upconverter.

Mixers with lower LO drive available.



Model Number	LO-RF Frequency (GHz)	IF Frequency (GHz)	LO Drive Level typ.	RF to IF Conversion Loss (dB) typ.	LO-RF Isolation typ.	Maximum LO + RF Input Power Level	RF and LO ports	IF Port
970AF/599 980AF/599	26.5-40		13 dBm	10 dB	28 dB	17 dBm	WR-28 Waveguide, UG-599/U Flange	SMA-Female
970BF/383 980BF/383	33-50	DC-12	13 dBm	10 dB	28 dB	17 dBm	WR-22 Waveguide, UG-383/U Flange	SMA-Female
970UF/383 9780UF/383	40-60	DC-12	13 dBm	10 dB	28 dB	17 dBm	WR-19 Waveguide, UG-383/U-M Flange	SMA-Female
970VF/385 980VF/385	50-75	DC-25	13 dBm	8 dB	28 dB	17 dBm	WR-15 Waveguide, UG-385/U Flange	SMA-Female
970EF/387 980EF/387	60-90	DC-30	13 dBm	10 dB	28 dB	17 dBm	WR-12 Waveguide, UG-387/U Flange	SMA-Female
970WF/387 980WF/387	75-110	DC-25	13 dBm	12 dB	28 dB	17 dBm	WR-10 Waveguide, UG-387/U-M Flange	SMA-Female



Description

Mi-wave supplies 971 series mixer with I (in phase) and Q (quadrature phase) outputs. They are offered over the RF range of DC to 110 GHz. Good LO to RF Isolation is achieved over a relatively broad RF and LO frequency ranges. Typical IF range is from DC to 5 GHz. Both waveguide and coaxial interfaces are offered as options for RF and LO ports. The mechanical design of these mixers is very compact and can be customized to suit any specific application and outline requirement. These IQ mixers find applications in communication equipment, radar sensors and instrumentation receivers.

- *Low Conversion Loss*
- *Wide Choice of IF Inputs*
- *With or Without RF Filter*

Model Number	Band	RF Frequency (GHz)	IF Frequency (GHz)	RF to IF Conversion Loss	Maximum LO + RF Input Power Level	RF Port	LO/IF Port
971AF/599	Ka-Band	26.5 - 40	DC - 12	10 dBm	17 dBm	WR-28 Waveguide, UG-599/U Flange	SMA (F)
971BF/383	Q-Band	33 - 50	DC - 12	10 dBm	17 dBm	WR-22 Waveguide, UG-383/U Flange	SMA (F)
971UF/383	U-Band	40 - 60	DC - 12	10 dBm	17 dBm	WR-19 Waveguide, UG-383/U-M Flange	SMA (F)
971VF/385	V-Band	50 - 75	DC - 12	10 dBm	17 dBm	WR-15 Waveguide, UG-385/U Flange	SMA (F)
971EF/387	E-Band	60 - 90	DC - 12	10 dBm	17 dBm	WR-12 Waveguide, UG-387/U-M Flange	SMA (F)
971WF/387	W-Band	75 - 110	DC - 12	10 dBm	17 dBm	WR-10 Waveguide, UG-387/U-M Flange	SMA (F)

970-980 S Custom Series

Custom Up/DownConverters - Transceivers/Receivers

MI-WAVE®

Millimeter Wave Products Inc.

970980 Up-Downconverter



970 Downconverter

Description

Mi-Wave's 970/980Series Millimeter Wave Down/Upconverters use MMIC balanced mixers to provide optimum electrical performance throughout the standard product line.

Mi-Wave's RF Upconverters and downconverters are reliable components for signal frequency conversion. Our models can be tailor-made with valuable features: multiple channels, individual Gain (Typ) controls, remote access, high input power tolerance, and multiple inputs/outputs, for example. The series is packaged for airborne, commercial, military, and other applications

- *Low Phase Noise*
- *Excellent Frequency Stability*
- *Superfine tuning steps*
- *Multichannel option available*
- *Gain (Typ) Control option available*
- *Low LO leakage*
- *High Image Rejection (Typ)*
- *Small Footprint*

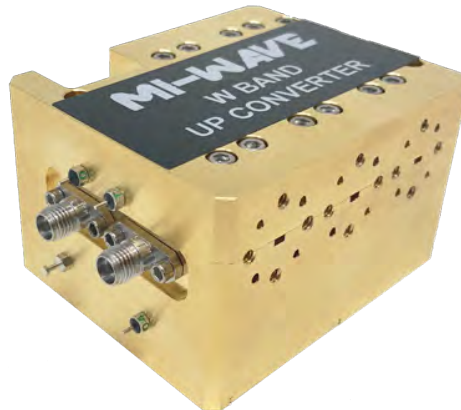

980 Upconverter

Model Number	Band	Type	Frequency (GHz)	Channels.	Packaging
980-10/385S	Crossband	Upconverter	2-18	1, 2, 3, 4	Commercial, Rack, Environmental
980A-34.5/381 S	Ka-Band	Upconverter	8.5-11.5	1, 2, 3, 4	Commercial, Rack, Environmental
970980A-35.61 /KF	Ka-Band	Up-Downconverter	35.61	1, 2, 3, 4	Commercial, Rack, Environmental
970B-38.25/387S	Q-Band	Downconverter	38.0-38.5	1, 2, 3, 4	Commercial, Rack, Environmental
970A-39.65/599	Ka-Band	Downconverter	39.4-39.9	1, 2, 3, 4	Commercial, Rack, Environmental
980B-43.25/387S	Q-Band	Upconverter	42.0-43.5	1, 2, 3, 4	Commercial, Rack, Environmental
970U-47.2/51 .4/1.85mmF	U-Band	Downconverter	42.2-51.4	1, 2, 3, 4	Commercial, Rack, Environmental
970980U B-47.2/51 .4/1.85mmF-PLO	U-Band	Up-Downconverter	47.2-51.4	1, 2, 3, 4	Commercial, Rack, Environmental
970E-70.4/86.4/387	E-Band	Downconverter	70.4-86.4	1, 2, 3, 4	Commercial, Rack, Environmental
970V-62.5/385	V-Band	Downconverter	70-65	1, 2, 3, 4	Commercial, Rack, Environmental
970980W-20/387S	W-band	Up-Downconverter	95-100	1, 2, 3, 4	Commercial, Rack, Environmental

990 Series

Balanced Phase Detectors

MI-WAVE®
Millimeter Wave Products Inc.

Description

Mi-Wave's 990 Series Balanced Phase Detectors feature a pair of Schottky diodes that mix or beat two input signals at the same frequency to produce a DC output voltage proportional to the phase difference of the input signals. Matching the two Schottky diodes ensures low DC offset results as well as good port-to-port Isolation.

- *High Sensitivity*
- *Good RF Isolation (Typ)*
- *High-reliability Beam-lead Diodes or MMIC's*

The 990 Series Phase Detectors can be used in applications such as phased-lock loops, phase-encoded systems and phase bridges.

Please consult for specifications.



Model Number	Band	Frequency Input (GHz)	Waveguide	Sensitivity Typ.	Bandwidth Typ.	RF Isolation Typ.	AM Suppression Typ.
990K	K-Band	18.0–26.5	WR-42	4 mV/o	4 %	20 dB	20 dB
990A	Ka-Band	26.5–40.0	WR-28	4 mV/o	4 %	20 dB	20 dB
990B	Q-Band	33.0–50.0	WR-22	4 mV/o	4 %	20 dB	20 dB
990U	U-Band	40.0–60.0	WR-19	3 mV/o	4 %	20 dB	20 dB
990V	V-Band	50.0–75.0	WR-15	3 mV/o	4 %	20 dB	20 dB
990E	E-Band	60.0–90.0	WR-12	2 mV/o	4 %	20 dB	20 dB
990W	W-Band	75.0–110.0	WR-10	2 mV/o	4 %	20 dB	20 dB

Appendix A

Rectangular Waveguides

Rectangular Waveguides										
			Recommended Operating Range for TE ₁₀ Mode		Cut-off for TE ₁₀ Mode					
Mi-Wave Band	Waveguide Designator (WR)	Waveguide Inner Dimensions in Inches	Frequency (GHz)	Wave-length (mm)	Frequency (GHz)	Wave-length (mm)	Theoretical Power CW Breakdown Lowest to Highest Frequency (KW)	Theoretical Attenuation Lowest to Highest Frequency (dB/ff)	Flange Type	Historic Designation
Ku	WR-62	0.622 x 0.311	12.4–18.0	24.2–16.6	9.486	31.60	400–600	.064–.030	Cover ¹ Choke	UG-419/U Flange UG-541/U Flange
K	WR-42	0.420 x 0.170	18.0–26.5	16.6–11.3	14.047	21.34	160–240	.17–.11	Cover ¹ Choke Cover	UG-595/U Flange UG-596A/U Flange UG-425/U Flange
A	WR-28	0.280 x 0.140	26.5–40.0	11.3–7.5	21.081	14.22	95–145	0.22–0.15	Cover ¹ Choke Cover	UG-599/U Flange UG-600/U Flange UG-381/U Flange
B	WR-22	0.224 X 0.112	33.0–50.0	9.1–6.0	26.342	11.38	62–90	0.31–0.21	Cover ¹ Cover Cover	UG-383/U Flange 719 719T
U	WR-19	0.188 x 0.094	40.0–60.0	7.5–5.0	31.357	9.56	47–64	0.39–0.27	Cover ¹² Cover Cover	UG-385/U Flange-M 710 720T
V	WR-15	0.148 x 0.074	50.0–75.0	6.0–4.0	39.863	7.52	29–42	0.78–0.53	Cover ¹	UG-385/U Flange
E	WR-12	0.122 x 0.061	60.0–90.0	5.0–3.3	48.350	6.20	20–29	0.78–0.53	Cover ¹	UG-387/U Flange
W	WR-10	0.100 x 0.050	75.0–110	4.0–2.7	59.010	5.08	14–20	1.02–0.71	Cover ¹²	UG-387/U Flange-M
F	WR-8	0.080 x 0.040	90.0–140.0	3.3–2.1	73.764	4.06	8.5–13.5	1.52–0.98	Pin ¹ Cover ²	714 UG-387/U Flange-M
D	WR-7	0.065 x 0.0325	110.0–170.0	2.7–1.8	90.786	3.30	5.8–9.0	2.12–1.35	Pin ¹ Cover ²	716 UG-387/U Flange-M
G	WR-5	0.051 x 0.0255	140.0–220.0	2.1–1.4	115.71	2.59	3.7–6.1	3.05–1.93	Pin ¹ Cover ²	715 UG-387/U Flange-M
H	WR-4	0.043 x 0.021	170.0 - 260.0	1.7-1.2	137.3	2.18				UG-387/U Flange-M
J	WR-3	0.864 x 0.034	220.0 - 330.0	1.4-0.9	173.5	1.73				UG-387/U Flange-M
WR-2.2	WR-2.2	0.022 x 0.011	330.0 - 500.0	0.9-0.6	263.0	1.14				UG-387/U Flange-M

1. Standard flange unless otherwise specified.

2. Modified (-M) means waveguide opening has been reduced appropriately. Screw and pin pattern are unchanged.

Finished Flange and Waveguide

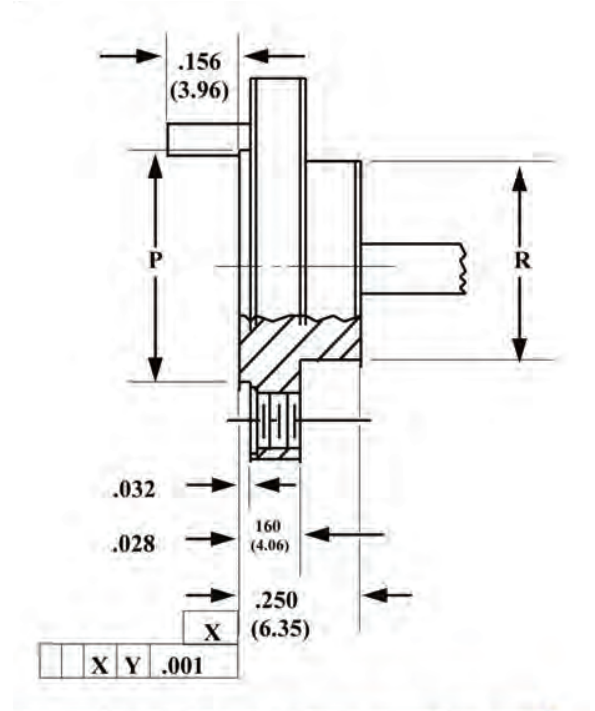
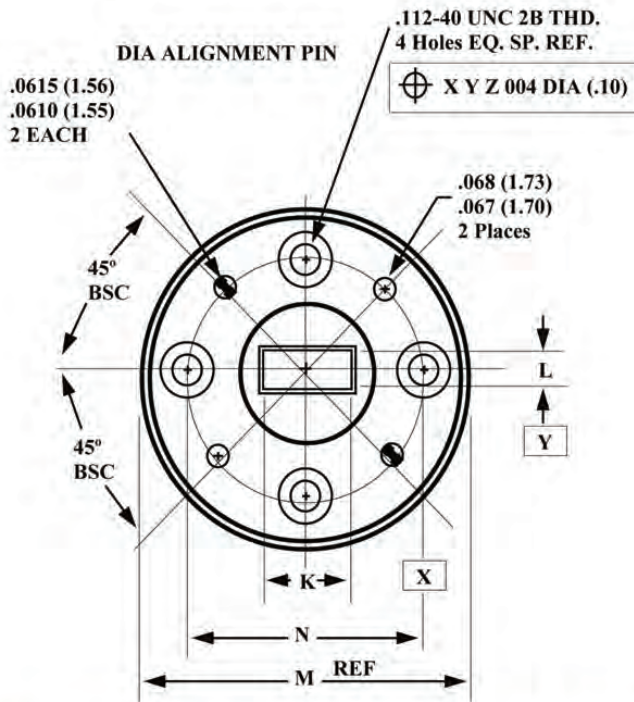

MIWV Band	Frequency Band (GHz)	MIL Part Number M3922/67	K ±.0015 (.04)	L ±.0015 (.04)	M ±.000/.002 (.05)	N BSC	P ±.005 (.13)	R ±.005 (.13)	EIA Waveguide Designation	MIWV Flange Designation	MIWV Flange Bank
K	18.0-26.5	-004	.4200 (10.67)	.1700 (4.32)	1.125 (28.58)	.9375 (23.81)	.625 (15.88)	.625 (15.88)	WR-42	UG-425/U Flange	101957-10
A	26.5-40.0	-005	.2800 (7.11)	.1400 (3.56)	1.125 (28.58)	.9375 (23.81)	.500 (12.70)	.468 (11.89)	WR-28	UG-381/U Flange	101957-1
B	33.0-50.0	-006	.2240 (5.69)	.1120 (2.84)	1.125 (28.58)	.9375 (23.81)	.500 (12.70)	.468 (11.89)	WR-22	UG-383/U Flange	101957-2
U	40.0-60.0	-007	.1180 (4.78)	.0940 (2.39)	1.125 (28.58)	.9375 (23.81)	.500 (12.70)	.468 (11.89)	WR-19	UG-383/U Flange-M	101957-3
V	50.0-75.0	-008	.1480 (3.76)	.0740 (1.88)	.750 (19.05)	.5625 (14.29)	.375 (9.53)	.312 (7.92)	WR-15	UG-385/U Flange	101957-4
E	60.0-90.0	-009	.1220 (3.10)	.0610 (1.55)	.750 (19.05)	.5625 (14.29)	.375 (9.53)	.312 (7.92)	WR-12	UG-387/U Flange	101957-5
W	75.0-110.0	-010	.1000 (2.54)	.0500 (1.27)	.750 (19.05)	.5625 (14.29)	.375 (9.53)	.312 (7.92)	WR-10	UG-387/U Flange-M	101957-6
F	90.0-140.0	N/A	.0800 (2.03)	.0400 (1.02)	.750 (19.05)	.5625 (14.29)	.375 (9.53)	.312 (7.92)	WR-8	UG-387/U Flange-M	101957-7
D	110.0-170.0	N/A	.0650 (1.65)	.0325 (.83)	.750 (19.05)	.5625 (14.29)	.375 (9.53)	.312 (7.92)	WR-7	UG-387/U Flange-M	101957-8
G	140.0-220.0	N/A	.0510 (1.30)	.0255 (.65)	.750 (19.05)	.5625 (14.29)	.375 (9.53)	.312 (7.92)	WR-5	UG-387/U Flange-M	101957-9
H	140.0-220.0	N/A	.043 (1.09)	.0215 (0.54)	.750 (19.05)	.5625 (14.29)	.375 (9.53)	.312 (7.92)	WR-4	UG-387/U Flange-M	
J	140.0-220.0	N/A	0.034 (0.86)	0.017 (0.43)	.750 (19.05)	.5625 (14.29)	.375 (9.53)	.312 (7.92)	WR-3	UG-387/U Flange-M	

Appendix C

Flange Blanks

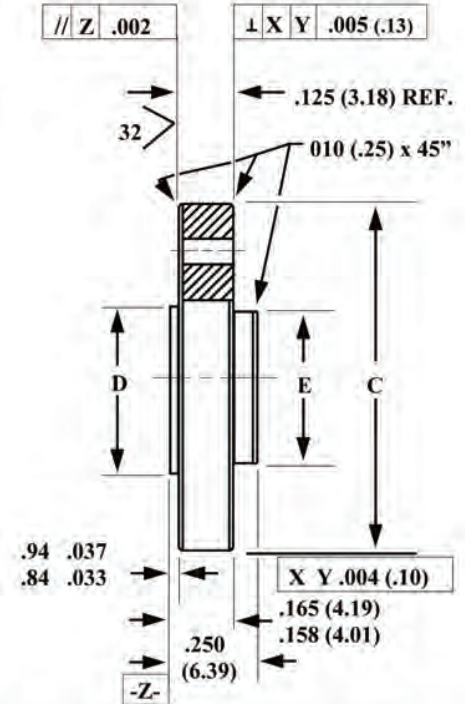
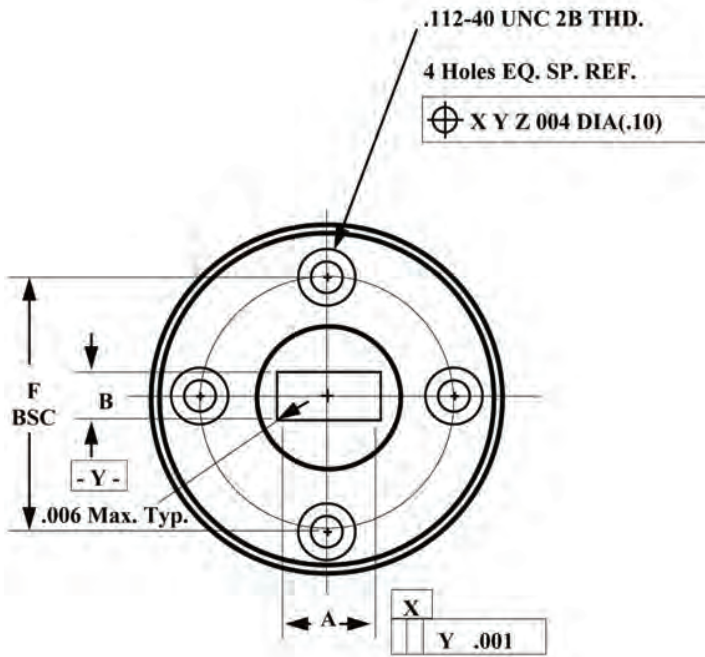

Note: Flange can be ordered with or without holes for pins

MIWV Band	Frequency Band (GHz)	MIL Part Number M3922/67	A +.002/-.000 (.05)	B +.002/-.000 (.05)	C +.000/-.002 (.05)	D ± .005 (.13)	E ± .005 (.13)	F BSC	MIWV Flange Designation
K	18.0–26.5	-004	.502 (12.75)	.252 (6.40)	1.125 (28.58)	.625 (15.88)	.625 (15.88)	.312 (7.92)	UG-425/U Flange
A	26.5–40.0	-005	.362 (9.19)	.222 (5.64)	1.125 (28.58)	.500 (12.70)	.468 (11.89)	.9375 (23.81)	UG-381/U Flange
B	33.0–50.0	-006	.306 (7.77)	.194 (4.93)	1.125 (28.58)	.500 (12.70)	.468 (11.89)	.9375 (23.81)	UG-383/U Flange
U	40.0–60.0	-007	.270 (6.86)	.167 (4.27)	1.125 (28.58)	.500 (12.70)	.468 (11.89)	56.25 (14.29)	UG-383/U Flange-M
V	50.0–75.0	-008	.230 (5.84)	.156 (3.96)	.750 (19.05)	.375 (9.53)	.312 (7.92)	56.25 (14.29)	UG-385/U Flange
E	60.0–90.0	-009	.204 (5.18)	.143 (3.63)	.750 (19.05)	.375 (9.53)	.312 (7.92)	56.25 (14.29)	UG-387/U Flange
W	75.0–110	-010	.182 (4.62)	.132 (3.35)	.750 (19.05)	.375 (9.53)	.312 (7.92)	56.25 (14.29)	UG-387/U Flange-M
F	90.0–140.0	N/A	.141 (3.58)	.101 (2.56)	.750 (19.05)	.375 (9.53)	.312 (7.92)	56.25 (14.29)	UG-387/U Flange-M
D	110.0–170.0	N/A	.126 (3.20)	.094 (2.39)	.750 (19.05)	.375 (9.53)	.312 (7.92)	56.25 (14.29)	UG-387/U Flange-M
G	140.0–220.0	N/A	.112 (2.84)	.089 (2.21)	.750 (19.05)	.375 (9.53)	.312 (7.92)	.9375 (23.81)	UG-387/U Flange-M
H	170.0 - 260.0	N/A							UG-387/U Flange-M
J	220.0 - 330.0	N/A							UG-387/U Flange-M

Appendix D and E

Cover Flanges-Flange Blanks

UG-419/U Flange (WR-62)

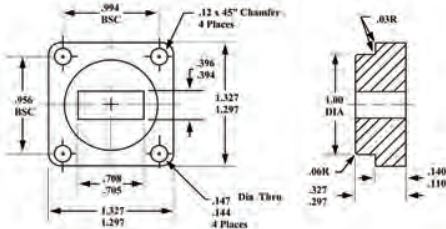

Cover Flanges — Finished Flange and Waveguide UG-419/U Flange (WR-62)

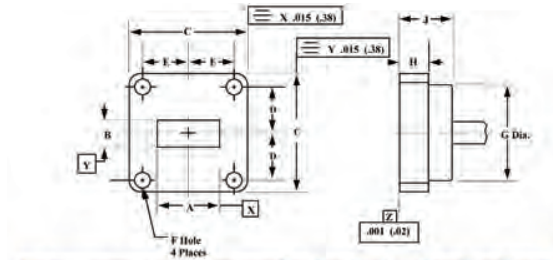

MIW Band	Frequency Band (GHz)	MIL Part Number M3922/53	A	B	C .015 (.38)	D BSC	E BSC	F ± .003 (.08)	G ± .015 (.38)	H ± 0.15 (.38)	J ± .015 (.38)	MIW Flange Bank
Ku	12.4 18.0	-4/005	.622 ± .002 (15.8) (.05)	.311 ± .002 (.79) (.05)	1.312 33.32	4.78 (12.14)	.497 (12.62)	.144 (3.66)	1.000 (25.40)	.125 (3.18)	.313 (7.95)	UG-419/U Flange

Appendix F

Choke Flanges

Finished Flange and Waveguide

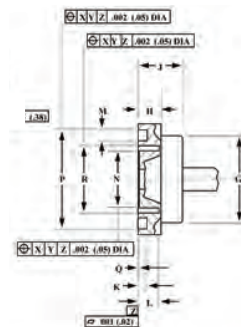
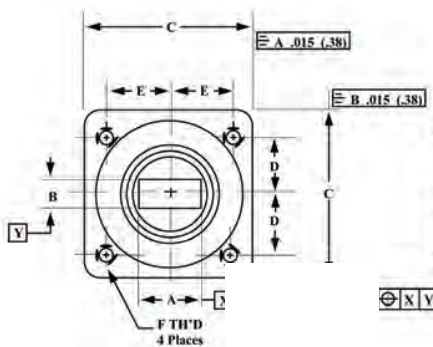

MIW Band	Frequency Band (GHz)	MIL Part Number M3922/59	MIW FLG. ESIG.	A	B	C .015 (.38)	D BSC	E BSC	F	G ± .015 (.38)	H ± .015 (.38)	J ± .015 (.38)	K ± .002 (.05)	L ± .002 (.05)	M ± .002 (.05)	N ± .002 (.05)	P ± .002 (.05)	Q ± .001 (.03)	R ± .002 (.05)
Ku	12.4 18.0	-2/001	UG541	.622±.002 (15.8)(.05)	.311±.002 (7.9)(.05)	1.312 (33.32)	.478 (12.14)	.497 (12.62)	.138-32 UNC-2B	1.000 (25.40)	.188 (4.78)	.375 (9.53)	.113 (2.87)	.190 (4.83)	1.58 (4.01)	.710 (18.03)	1.208 (30.68)	.0075 (.19)	.828 (21.03)
K	18.0 26.5	-2/003	UG596	.420±.002 (10.67)(.05)	.170±.002 (4.32)(.05)	.875 (22.23)	.335 (8.51)	.320 (8.13)	.112-40 UNC-2B	.625 (15.88)	.156 (3.96)	.285 (7.24)	0.42 (1.07)	.129 (3.28)	0.87 (2.21)	.472 (11.99)	.761 (19.33)	.005 (.13)	.536 (13.61)
A	26.5 40.0	-2/005	UG600	.280±.0014 (7.11)(.04)	.140±.0014 (3.56)(.04)	.750 (19.05)	.265 (6.73)	.250 (6.35)	.112-40 UNC-2B	.500 (12.70)	.109 (2.77)	.210 (5.33)	.050 (1.27)	.086 (2.18)	.096 (2.44)	.321 (8.15)	.596 (15.14)	.003 (.08)	.372 (9.45)

Finished Flange and Waveguide

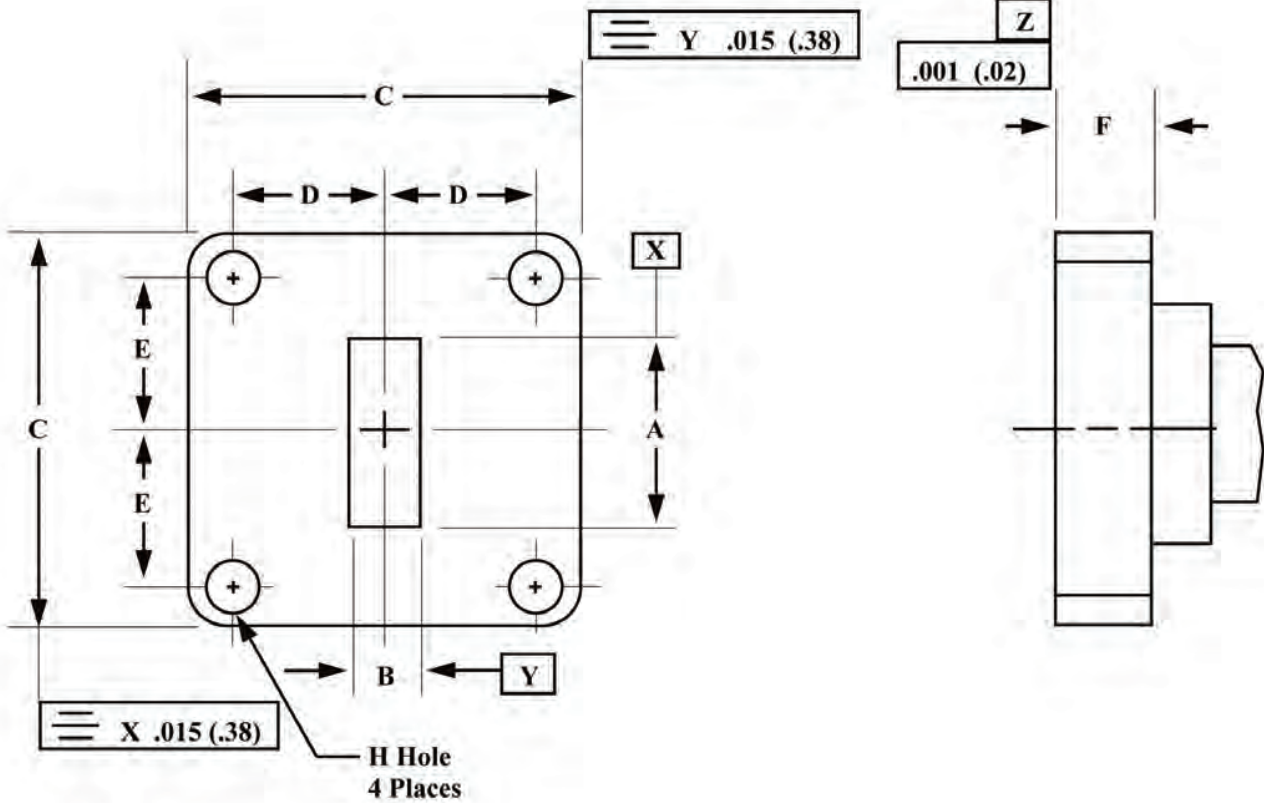

MIWV Band	Frequency Band (GHz)	MIL Part Number M3922/54-4	A ± .0015 (.04)	B ± .0015 (.04)	C	D BSC	E BSC	F	H	MIWV Flange
K	18.0 26.5	-001	.4200 (10.67)	.1700 (4.32)	.875 ± 0.015 (22.22)(.38)	.335 (8.51)	.320 (8.13)	.156 ± 0.015 (3.96)(.38)	.116 + 0.002 (2.95)(.05)	UG-595/U Flange
A	26.5 40.0	-003	.2800 (7.11)	.1400 (3.56)	.750 ± 0.005 (19.05)(1.3)	.265 (6.75)	.250 (6.35)	.109 ± 0.005 (2.77)(.38)	.116 + 0.002 (2.95)(.05)	UG-599/U Flange
B	33.0 50.0	N/A	.2240 (5.69)	.1120 (2.84)	.750 ± 0.005 (19.05)(1.3)	.265 (6.75)	.250 (6.35)	.156 ± 0.005 (3.96)(.38)	.116 + 0.002 (2.95)(.05)	719 (UG-599/U FlangeM)
B	33.0 50.0	N/A	.2240 (5.69)	.1120 (2.84)	.750 ± 0.005 (19.05)(1.3)	.265 (6.75)	.250 (6.35)	.156 ± 0.005 (3.96)(.38)	.112-40 UNC-2B	719T
U	40.0 60.0	N/A	.1880 (4.78)	.0940 (2.39)	.750 ± 0.005 (19.05)(1.3)	.265 (6.75)	.250 (6.35)	.187 ± 0.005 (4.75)(.38)	.116 + 0.002 (2.95)(.05)	720 (UG-599/U FlangeM)
U	40.0 60.0	N/A	.1880 (4.78)	.0940 (2.39)	.750 ± 0.005 (19.05)(1.3)	.265 (6.75)	.250 (6.35)	.187 ± 0.005 (4.75)(.38)	.112-40 UNC-2B	720T

Flange Blank

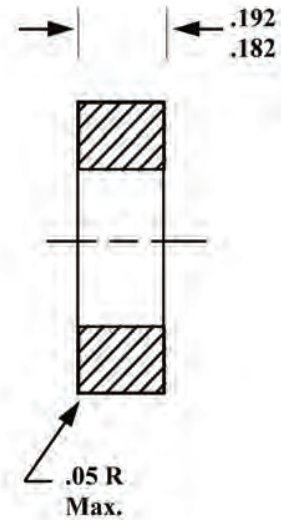
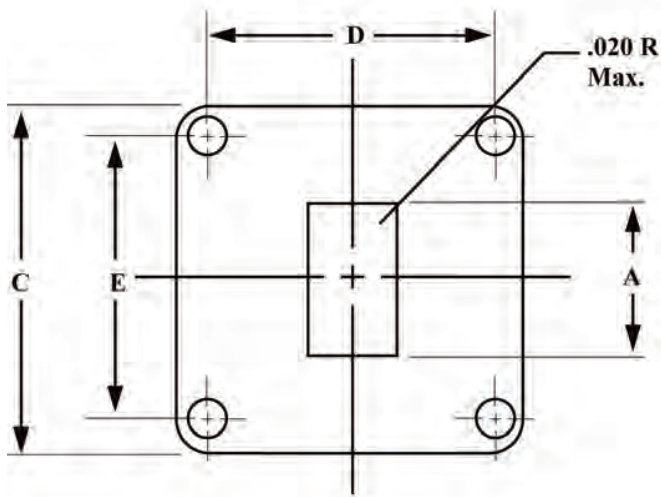
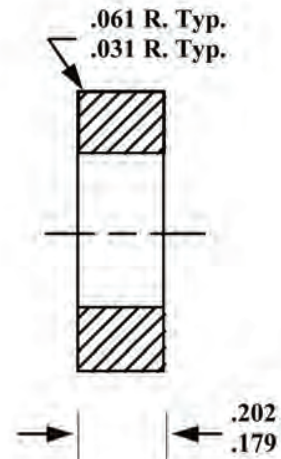
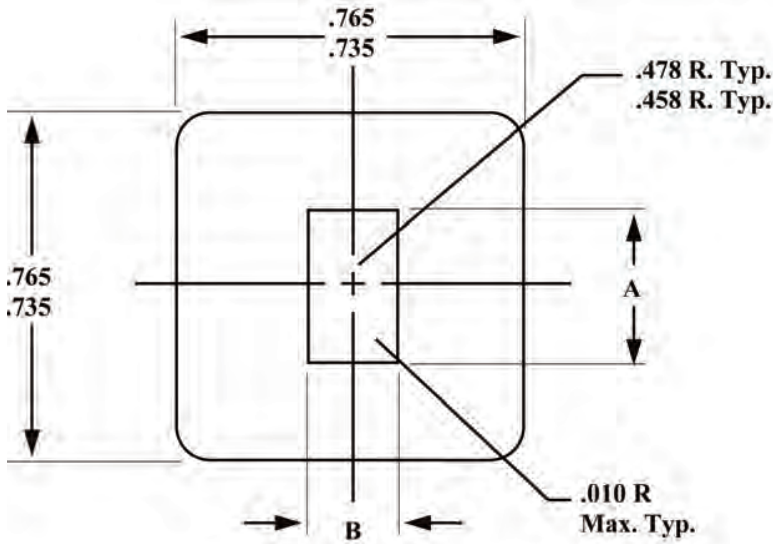

MIWV Flange Designation	A	B	C	D BSC	E BSC
UG 599A	.364 .362	.224 .222	.755 .745	.530	.500
UG 595K	.505 .503	.255 .253	.890 .860	.670	.640

MIWV Part Number	A +.002-.000	B +.002-.000
719B	.306	.194
720U	.270	.176

Appendix I

Antenna TE₁₁ Circular Waveguides

MI-WAVE®
Millimeter Wave Products Inc.

Band	Pipe ID	Frequency Band
X-1	1.094	8.2-9.97
X-2	0.938	8.5-11.6
X-3	0.797	9.97-12.4
Ku-1	.660	12.4-14.6
Ku-2	.550	14.6-17.5
K-1	.470	17.5-20.5
K-2	.396	20.5-24.5
K-3	.328	24.5-26.5
A-0	.328	26-28.5
A-1	.281	28.5-33
A-2	.250	33-38.5
A-3	.219	38.5-43
B-0	.250	33-38.5
B1	.219	38.5-43
B-2	.188	43-50
U-0	.219	38.5-43
U-1	.188	43-50
U-2	.165	50-58
V-0	.165	50-58
V-1	.141	58-68
V-2	.125	68-77
E-0	.141	58-68
E-1	.125	68-77
E-2	.110	77-87
E-3	.094	87-100
W-0	.110	77-87
W-1	.094	87-100
W-2	.082	100-112
F-0	.094	87-100
F-1	.082	100-112
F-2	.075	112-125
F-3	.067	125-140
D-0	.082	100-112
D-1	.075	112-125
D-2	.067	125-140
D-3	.059	140-160
G-0	.067	125-140
G-1	.059	140-220

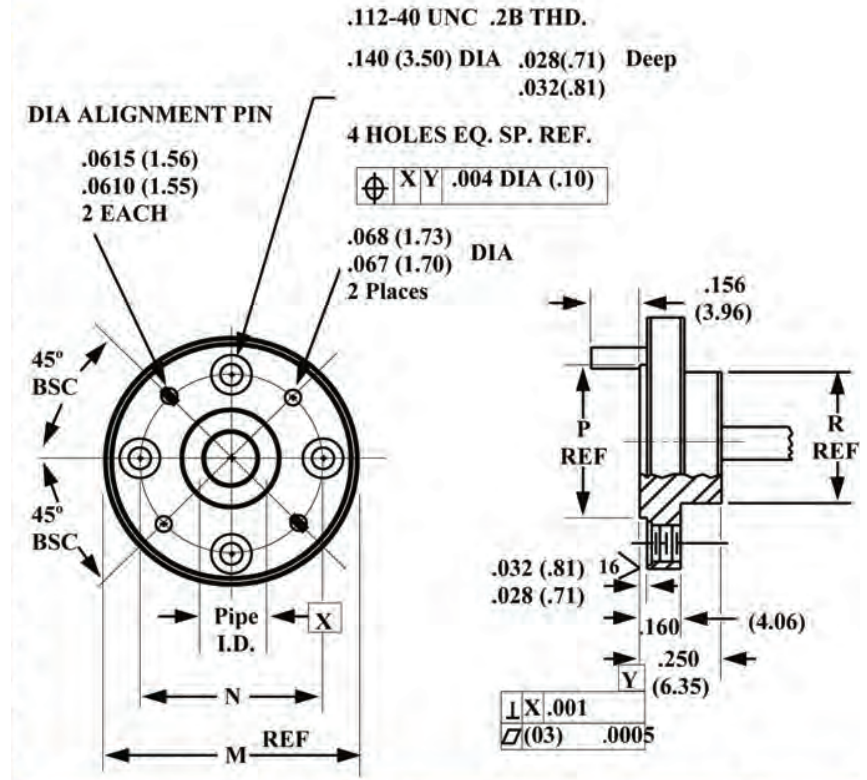

MIWV Band	M +.000/.002 (.05)	N BSC	P +.005 (.13)	R +.005 (.13)	MIWV Flange Designation	MIWV Flange Blank
Ku	1.44 (36.68)	1.250 (28.6)	.967 (24.6)	.967 (24.6)	731	108872
K	1.125 (28.58)	.9375 (23.8)	.625 (15.88)	.625 (15.88)	UG-425/U Flange	107729-7
A	1.125 (28.58)	.9375 (23.8)	.500 (12.70)	.468 (11.89)	UG-381/U Flange	107729-1
B	1.125 (28.58)	.9375 (23.8)	.500 (12.70)	.468 (11.89)	UG-383/U Flange	107729-2
U	1.125 (28.58)	.9375 (23.8)	.500 (12.70)	.468 (11.89)	UG-385/U Flange-M	107729-3
V	.750 (19.05)	.5625 (14.29)	.375 (9.53)	.312 (7.92)	UG-385/U Flange	107729-4
E	.750 (19.05)	.5625 (14.29)	.375 (9.53)	.312 (7.92)	UG-387/U Flange-M	107729-5
W	.750 (19.05)	.5625 (14.29)	.375 (9.53)	.312 (7.92)	UG-387/U Flange-M	107729-6
F	.750 (19.05)	.5625 (14.29)	.375 (9.53)	.312 (7.92)	UG-387/U Flange-M	107729-8
D	.750 (19.05)	.5625 (14.29)	.375 (9.53)	.312 (7.92)	UG-387/U Flange-M	107729-9
G	.750 (19.05)	.5625 (14.29)	.375 (9.53)	.312 (7.92)	UG-387/U Flange-M	107729-10

Where frequency has two pipe sizes take smaller pipe, except for 100 and higher, then take larger pipe.

Appendix J

The Effect of VSWR (Typ) on Transmittal Power

VSWR (Typ)	Return Loss (dB)	VSWR (Typ) (dB)	Volt REFL COEFF	XMSN Loss (dB)	Power XMIT (%)	Power REFL (%)
1.006	50.00	0.05	0.00	.0000	100.	0.00
1.01	46.06	0.09	0.00	.0001	100.	0.00
1.011	45.00	0.10	0.01	.0001	100.	0.00
1.02	40.09	0.17	0.01	.0004	99.99	0.01
1.020	40.00	0.17	0.01	.0004	99.99	0.01
1.03	36.61	0.26	0.01	.0009	99.98	0.02
1.036	35.00	0.31	0.02	.0014	99.97	0.03
1.04	34.15	0.34	0.02	.0017	99.96	0.04
1.045	33.15	0.38	0.02	.0021	99.95	0.05
1.05	32.26	0.42	0.02	.0026	99.94	0.06
1.06	30.71	0.51	0.03	.0037	99.92	0.08
1.065	30.00	0.55	0.03	.0043	99.90	0.10
1.07	29.42	0.59	0.03	.0050	99.89	0.11
1.08	28.30	0.67	0.04	.0064	99.85	0.15
1.09	27.32	0.75	0.04	.0081	99.81	0.19
1.10	26.44	0.83	0.05	.0099	99.77	0.23
1.11	25.66	0.91	0.05	.0118	99.73	0.27
1.119	25.00	0.98	0.06	.0138	99.68	0.32
1.12	24.94	0.98	0.06	.0139	99.68	0.32
1.13	24.29	1.06	0.06	.0162	99.63	0.37
1.135	24.00	1.10	0.06	.0173	99.60	0.40
1.14	23.69	1.14	0.07	.0186	99.57	0.43
1.15	23.13	1.21	0.07	.0212	99.51	0.49
1.152	23.00	1.23	0.07	.0212	99.50	0.50
1.16	22.61	1.29	0.07	.0239	99.45	0.55
1.17	22.12	1.36	0.08	.0267	99.39	0.61
1.173	22.00	1.38	0.08	.0275	99.37	0.63
1.18	21.66	1.44	0.08	.0297	99.32	0.68
1.19	21.23	1.51	0.09	.0328	99.25	0.75
1.196	21.00	1.55	0.09	.0346	99.21	0.79
1.20	20.83	1.58	0.09	.0360	99.17	0.83
1.21	20.44	1.66	0.10	.0394	99.10	0.90
1.22	21.08	1.73	0.10	.0429	99.02	0.98
1.222	20.00	1.74	0.10	.0436	99.00	1.00
1.23	19.73	1.80	0.10	.0464	98.94	1.06
1.24	19.40	1.87	0.11	.0501	98.85	1.15
1.25	19.08	1.94	0.11	.0540	98.77	1.23
1.253	19.00	1.96	0.11	.0550	98.74	1.26
1.26	18.78	2.01	0.12	.0579	98.68	1.32
1.27	18.49	2.08	0.12	.0619	98.59	1.41
1.28	18.22	2.14	0.12	.0660	98.49	1.51
1.288	18.00	2.20	0.13	.0694	98.42	1.58
1.29	17.95	2.21	0.13	.0702	98.40	1.60
1.30	17.89	2.28	0.13	.0745	98.30	1.70

VSWR (Typ)	Return Loss (dB)	VSWR (Typ) (dB)	Volt REFL COEFF	XMSN Loss (dB)	Power XMIT (%)	Power REFL (%)
1.31	17.45	2.35	0.13	0.08	98.20	1.80
1.32	17.21	2.41	0.14	0.08	98.10	1.90
1.329	17.00	2.47	0.14	0.09	98.00	2.00
1.33	16.98	2.48	0.14	0.09	97.99	2.01
1.34	16.75	2.54	0.15	0.09	97.89	2.11
1.35	18.54	2.61	0.15	0.10	97.78	2.22
1.36	16.33	2.61	0.15	0.10	97.67	2.33
1.37	16.13	2.73	0.16	0.11	97.56	2.44
1.377	16.00	2.78	0.16	0.11	97.49	2.51
1.38	15.94	2.80	0.16	0.11	97.45	2.55
1.39	15.75	2.86	0.16	0.11	97.49	2.51
1.40	15.56	2.92	0.17	0.12	97.22	2.78
1.41	15.38	2.98	0.17	0.13	97.11	2.89
1.42	15.21	3.05	0.17	0.13	96.99	3.01
1.43	15.04	3.11	0.18	0.14	96.87	3.13
1.433	15.00	3.12	0.18	0.14	96.84	3.16
1.44	14.88	3.17	0.18	0.14	96.75	3.25
1.45	14.72	3.23	0.18	0.15	96.63	3.37
1.46	14.56	3.29	0.19	0.15	96.50	3.50
1.464	14.50	3.31	0.19	0.16	96.45	3.55
1.47	14.41	3.35	0.19	0.16	96.38	3.62
1.48	14.26	3.41	0.19	0.17	96.25	3.75
1.49	14.12	3.46	0.20	0.17	96.13	3.87
1.499	14.00	3.51	0.20	0.18	96.02	3.98
1.50	13.96	3.52	0.20	0.18	96.00	4.00
1.536	13.50	3.73	0.21	0.20	95.53	4.47
1.55	13.32	3.81	0.22	0.21	95.35	4.65
1.577	13.00	3.96	0.22	0.22	94.99	5.01
1.60	12.74	4.08	0.23	0.24	94.67	5.33
1.622	12.50	4.20	0.24	0.25	94.38	5.62
1.65	12.21	4.35	0.25	0.27	93.98	6.02
1.671	12.00	4.46	0.25	0.28	93.69	6.31
1.70	11.73	4.61	0.26	0.30	93.28	6.72
1.725	11.50	4.74	0.27	0.32	92.92	7.08
1.75	11.29	4.86	0.27	0.34	92.56	7.44
1.785	11.00	5.03	0.28	0.36	92.06	7.94
1.80	10.88	5.11	0.29	0.37	91.84	8.16
1.851	10.50	5.35	0.30	0.41	91.09	8.16
1.90	10.16	5.58	0.31	0.44	90.37	9.63
1.925	10.00	5.69	0.32	0.46	90.00	10.00
2.00	9.54	6.02	0.33	0.51	88.89	11.11
2.50	7.36	7.96	0.43	0.88	81.63	18.37
3.00	6.02	9.54	0.50	1.25	75.00	25.00
3.50	5.11	10.88	0.56	1.60	69.14	30.86

Appendix K

Beamwidth and Gain Selection Charts

MI-WAVE[®]
Millimeter Wave Products Inc.

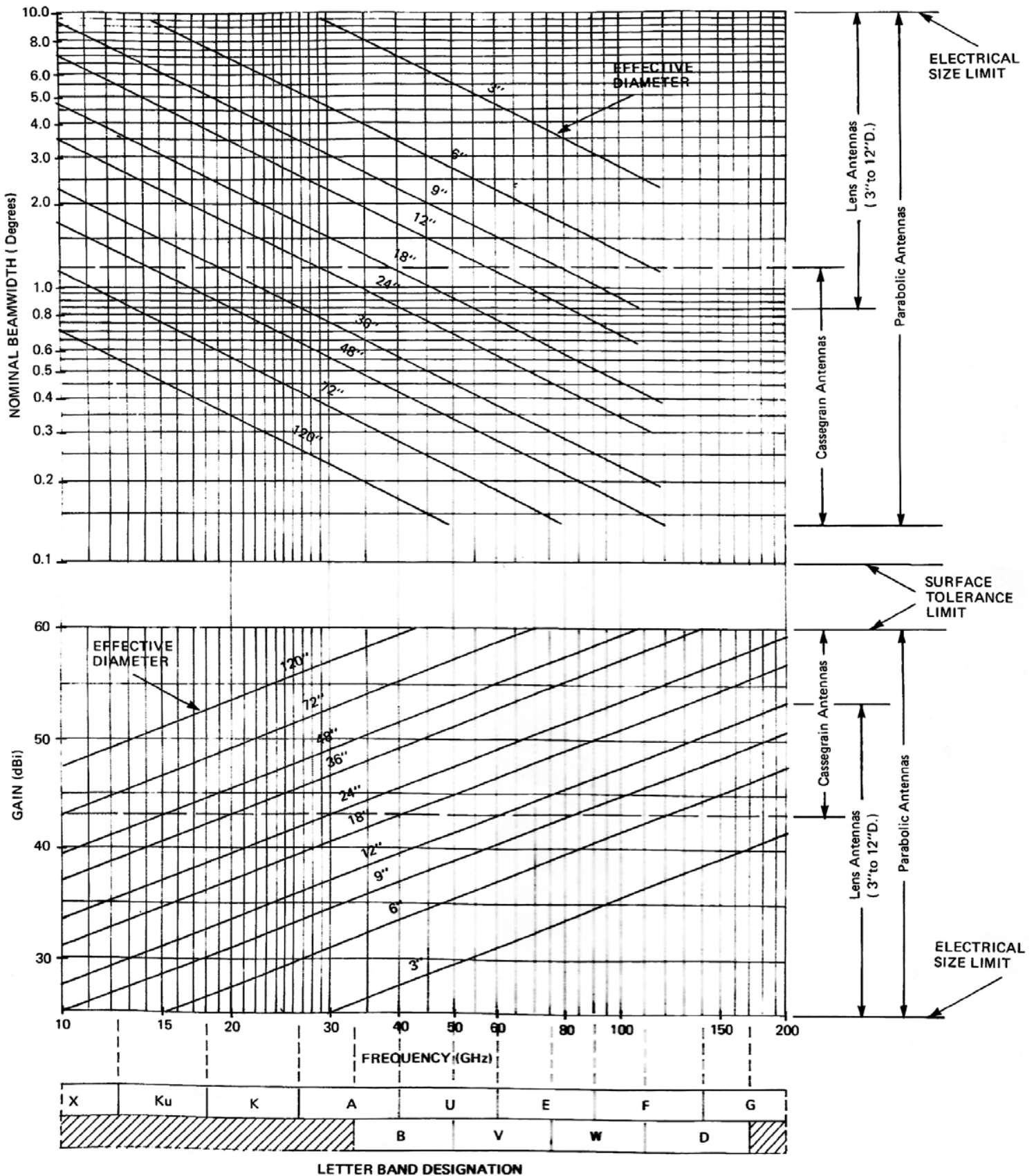

Terms and Conditions

MI-WAVE®
Millimeter Wave Products Inc.

The following terms and conditions apply to all purchase orders accepted and all quotations submitted by Mi-Wave, hereinafter referred to as Mi-Wave. Orders accepted by Mi-Wave are based on Buyer's acceptance of these Terms and Conditions. Return of this acknowledgment by Mi-Wave, and only such acknowledgment, constitutes acceptance of the Buyer's purchase order. Acceptance by the Buyer of merchandise shipped against any purchase order acknowledges acceptance of the Terms and Conditions set forth in this document.

Failure of Mi-Wave to enforce any of these provisions does not relieve Buyer from all Terms and Conditions contained herein.

The term payment is net thirty (30) days FOB the Mi-Wave facility where commitment to shipping carrier is made. Firms not on open account will be required to prepay or accept material COD.

Cancellation of an order by the Buyer will be subject to payment of all costs incurred up to the date of notification of termination. Buyer will accept all finished goods, work in progress, and direct material. Costs will be calculated using standard accounting procedures including profit and G & A. If said termination is a result of reduction or cancellation of a Government contract to the Buyer, the provisions of the current applicable Defense Acquisition Regulations shall apply.

Mi-Waves' warranty obligations shall be limited to, at Mi-Waves' option, repairing, replacing, or granting a credit at the purchase order price for items returned to Mi-Wave at the Buyer's expense within 90 days of delivery that are determined to be defective by analysis at Mi-Waves' facility. Material that has been misapplied, mechanically or electrically over stressed, repaired or altered in any way will not be warranted. Mi-Wave warrants that its products conform to applicable specifications and are free from defects in material or workmanship. No other warranties exist or are implied. This warranty is not transferable. Repairs at the Buyer's expense will only be accepted when accompanied by a purchase order issued to Mi-Wave for estimated cost to repair. RMA's are issued only for in warranty repairs.

Quoted prices shall be valid and firm for thirty (30) days. All prices are subject to change without notice. Prices accepted by the Buyer and acknowledged by Mi-Wave shall remain in effect throughout the term of the effective quote date.

Mi-Wave will not be responsible for delays caused by events outside of its control. Mi-Wave assumes no liability of any kind resulting from failure to meet delivery schedules.

All applicable taxes will appear on invoices issued by Mi-Wave to be paid by the Buyer, unless a properly executed exemption certificate is received with the purchase order or shipment and invoicing.

Mi-Wave agrees to indemnify Buyer against actions brought against the Buyer for infringement of valid patents. Mi-Wave will not be a party to an action resulting from the use of its components in a collection or assembly of components that are alleged to violate a patented circuit, system, equipment, assembly or any combination of components so described. Immediate notification of Mi-Wave regarding any action relating to patents or infringement of same is required but in no case shall such notice be delayed in excess of five (5) working days.

Further, delivery of components to the Buyer does in no way imply any license agreement regarding patents or disclosures held or in process by Mi-Wave. All rights under such patents remain with Mi-Wave.

Source inspection of material or components by the Buyer or any designate of his will be quoted as a separate line item.

Failure to include this line item will not relieve the Buyer from the obligation of payment for said service. Source inspection that requires witnessing of electrical tests must be preceded by mutual acceptance of a test procedure. Such test procedure, if generated by Mi-Wave, will be at the expense of the Buyer.

Mi-Wave may change, delete, or add additional conditions without notice. Such changes will be made a part of all quotes and acceptance of purchase orders.

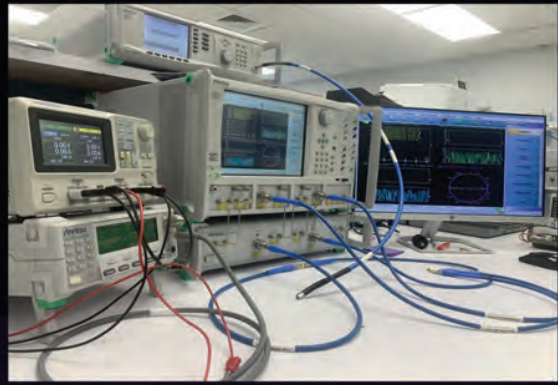

Millimeter Wave Products, Inc. is an award-winning global provider of millimeter wave products and microwave technology, components, and assemblies.

We offer volume production, individual components, systems, and MORE, in the 7GHz to 500GHz spectrum.

We manufacture all our products in our Florida, USA-based facility. We work with a wide range of global clients, supporting research and real-world deployments across multiple industries. From standard individual components to custom-designed parts and sub assemblies, we are your best choice for Millimeter Wave and Microwave Products!

Would you like more information about our components and capabilities?

Contact our sales and engineering team today!

Apply MiWave's experience, talent, and manufacturing resources to your project for optimized solutions!



WWW.MI WV.COM
2007 GANDY BLVD N, SUITE 1310
ST. PETERSBURG, FL 33702

Tel: (727) 563-0034
Email: sales@miwv.com